



22.1  
41-73

O'ZBEKISTON RESPUBLIKASI OLIY  
VA O'RTA MAXSUS TA'LIM VAZIRLIGI

F. R. USMONOV, R. D. ISOMOV, B. O. XO'JAYEV

# MATEMATIKADAN QO'LLANMA

*O'zbekiston Respublikasi Oliy va o'rta maxsus ta'lim vazirligi  
tomonidan o'quv qo'llanma sifatida tavsiya etilgan*

I - QISM

Toshkent  
«Yangi asr avlodi»  
2006



22.1  
41-73

O'ZBEKISTON RESPUBLIKASI OLIY  
VA O'RTA MAXSUS TA'LIM VAZIRLIGI

F. R. USMONOV, R. D. ISOMOV, B. O. XO'JAYEV

# MATEMATIKADAN QO'LLANMA

*O'zbekiston Respublikasi Oliy va o'rta maxsus ta'lim vazirligi  
tomonidan o'quv qo'llanma sifatida tavsiya etilgan*

I - QISM

Toshkent  
«Yangi asr avlodi»  
2006

*Mazkur qo'llanma O'zbekiston Respublikasi Oliy va o'rta maxsus ta'lim vazirligi O'rta maxsus, kasb-hunar ta'limi markazi tasdiqlagan dasturlar asosida yozilgan bo'lib, akademik, litsey, kasb-hunar kollejlari o'quvchilari uchun mo'ljallangan. Qo'llanma matematika fani bo'yicha o'quv dasturidagi asosiy materiallarni o'z ichiga oladi. Unda keltirilgan matematik tushunchalar, ta'riflar, qoidalar va teoremlar, masala-misollarni yechish namunalari bilan sodda va ravon tilda bayon qilingan, har bir bobda mustaqil yechish uchun testlar keltirilgan.*

**Taqrizchilar:**

**Sh. SHORAHMEDOV,**

fizika-matematika fanlari doktori, professor

**T. MAVLONOV,**

texnika fanlari doktori, professor

**A. MAMATQULOV,**

fizika-matematika fanlari nomzodi, dotsent

**M. SHARIPOVA,**

Respublikada xizmat ko'rsatgan xalq ta'limi xodimi

Respublikada xizmat ko'rsatgan o'qituvchi,  
professor M.A.Mirzahmedov va dotsent M.Shorahimov tahriri ostida

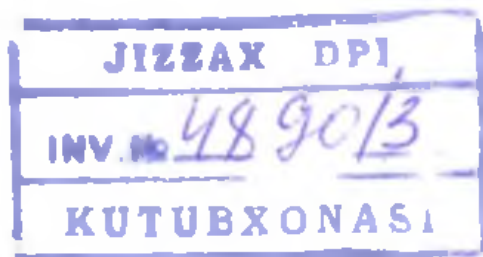

ISBN 6-633-01943

© F.R. Usmonov, R.D. Isomov, B.O. Xo'jaev. «Matematikadan qo'llanma». «Yangi asr avlodi», 2006-yil.

**Respublikada xizmat ko'rsatgan  
o'qituvchilar, padari buzrukvorlarimiz  
Rahimjon Usmonov, Jamol Isomov,  
Odiljon Xo'jayevning yorqin xotiralariga  
bag'ishlanadi**

## **SO'ZBOSHI**

*O'zbekiston Respublikasi hukumati tomonidan «Ta'lim to'g'risida»gi qonun va «Kadrlar tayyorlash milliy dasturi»da ifodalangan talablarga to'liq javob beradigan darsliklar, o'quv qo'llanmalari, uslubiy qo'llanmalar yaratish hozirgi kunning dolzarb masalasi bo'lib qolmoqda.*

*Ushbu qo'llanna kasb-hunar kollejlari va akademik litseylarning matematika fani bo'yicha o'z bilimlarini chuqurlashtirmoqchi va mustahkamlamoqchi bo'lgan o'quvchilari uchun hamda bu fanni mustaqil o'zlashtirib, oliy o'quv yurtlariga kirishni niyat qilgan yoshlarga mo'ljallangan.*

*Qo'llanna matematika fani o'quv dasturidagi algebra va analiz asoslari bo'yicha asosiy mavzularni o'z ichiga olgan 15 bobdan iborat bo'lib, har bir bobda nazariy ma'lumotlardan tashqari masala-misollarning yechilish namunalariga, usullariga katta e'tibor berilgan. Unda masala-misollar yechishga matematikani chuqur o'rganishning asosiy vazifasi sifatida qaraladi. Asosiy maqsad u yoki bu masalani yechishda nazariy materialga chuqurroq qarash, umumlashtirish, yechimlarni tahlil qilish malakalarini o'quvchida shakllantirishga qaratilgan bo'lib, har bir bob oxirida mustaqil ishlash uchun test topshiriqlari berilgan va ularning javoblari ham keltirilgan.*

*Mualliflar qo'llannadan akademik litsey, kasb-hunar kollejlarining o'qituvchilari, matematika to'garaklarining rahbarlari o'z faoliyatlarida foydalanishlari mumkin bo'lgan materiallarni topadilar deb umid qilishadi. Akademik litseylarda matematika fani bo'yicha amalda bo'lgan darsliklarda maxsus tenglamalarni («qaytma» tenglamalar, transsendent va parametrli tenglamalar) yechish. Bezu teoremasi va uning natijalarini ko'phadlarni ko'paytuvchilarga ajratish hamda yuqori darajali tenglamalarni yechishga tatbiqi kabi masalalarga yetarli e'tibor*

berilmaganini hisobga olib, ushbu qo'llanmada bu mavzular ham tegishli masala-misollarning yechimlari bilan keltirib bayon qilingan.

Bundan tashqari, qo'llanma 1500 dan ko'proq masala-misollar jamlangan to'plam sifatida ham qiziqish uyg'otadi. Bu masala-misollarning uchdan bir qismidan ko'prog'i yechimlari bilan keltirilgan.

Qo'llanmaning yaratilishida, undagi ayrim boblarning yozilishida, masala va misollarni tanlashda bergan yordamlari, maslahatlari uchun Toshkent Davlat Iqtisodiyot universiteti qoshidagi Iqtisodiyot gimnaziya-sining o'qituvchilari S.Do'stmurodov (I, II boblar), G'.Oxunjonov (III bob), t.f.n. A.Saidov (IX-X boblar), O.Mirshoxo'jayev, M.Isomova (XII-XIV boblar), dotsent F.Zokirov (V, XIII boblar) kabi o'qituvchilarning hamda xolisona tanqid, uning yozilishida yo'l qo'yilgan kamchiliklarni ko'rsatganliklari uchun professor M.Mirzaahmedovning beminnat mehnatlarini mualliflar hurmat bilan e'tirof etadilar.

Qo'llanma kamchiliklardan xoli bo'lmasligi mumkin. Uni yanada mukammallashtirishga qaratilgan tanqidiy fikr va mulohazalarini bildiradigan hamkasblarga oldindan o'z tashakkurimizni izhor etamiz.

**Mualliflar**

## NATURAL SONLAR

*1-§. Natural sonlar va ular ustida amallar*

**1.1. Raqam, natural son tushunchalari.** Sanash natijalarini ifodalash uchun 0, 1, 2, 3, 4, 5, 6, 7, 8, 9 belgilaridan foydalaniladi va ular *raqamlar* deb ataladi. Bu raqamlar o'nta. Shuning uchun bizning sanoq sistemamiz o'nlik sanoq sistemasi deyiladi.

Natural son tushunchasi matematikaning eng sodda, boshlang'ich tushunchalaridan biridir.

*T a ' r i f:* *natural son deb, sanashda ishlatiladigan yoki sanash natijasida kelib chiqadigan sonlarga aytiladi.*

Natural sonlar to'plami  $N$  harfi bilan belgilanadi va quyidagicha yoziladi:  $N = \{1; 2; 3; \dots; n; n + 1; \dots\}$ . Natural sonlar to'plami cheksiz bo'lib, eng kichigi 1 va eng kattasi mavjud emas, chunki har qanday natural songa 1 qo'shilsa, u oldingisidan katta bo'ladi.

Har qanday natural sonni yuqoridagi 10 ta raqam yordamida yozish mumkin. Masalan: 367; 1 013; 39 871; 137 997 803 va h.k.

Ko'p xonali sonlar umumiy ko'rinishda quyidagicha yoziladi:

$$x = a \cdot 10^n + b \cdot 10^{n-1} + \dots + e \cdot 10 + f,$$

bu yerda  $n$  – natural son,  $a, b, \dots, e, f$  lar 1 dan 10 gacha bo'lgan natural sonlardir. Bu tenglik **natural sonning o'ning darajalari bo'yicha yoyilmasi** deyiladi. Masalan,  $x = 437968$  soni  $x = 4 \cdot 10^5 + 3 \cdot 10^4 + 7 \cdot 10^3 + 9 \cdot 10^2 + 6 \cdot 10 + 8$  kabi yoziladi.

**1.2. Natural sonlar ustida amallar. 1. Natural sonlarni qo'shish.** Natural sonlar yig'indisi yana natural son bo'ladi. Masalan,  $17 + 23 = 40$ ;  $29 + 62 = 91$  va h.k. Umuman,  $a$  va  $b$  natural sonlar bo'lsa, u holda

$$a + b = c \tag{1}$$

bo'ladi, bu yerda  $c$  – natural son. (1) tenglikda  $a$  va  $b$  *qo'shiluvchilar*,  $c$  esa *yig'indi* deyiladi. Natural sonlarni qo'shish quyidagi xossalarga ega:



1) O'rin almashtirish:

$$a + b = b + a,$$

ya'ni qo'shiluvchilarning o'rinlari almashgani bilan yig'indining qiymati o'zgarmaydi.

M i s o l:  $17 + 32 = 32 + 17 = 49$ ;  $109 + 235 = 235 + 109 = 344$ .

2) Guruhlash:  $(a + b) + c = a + (b + c)$  tenglik o'rinli.

M i s o l:  $(15 + 48) + 22 = 15 + (48 + 22) = 85$ .

**2. Natural sonlarni ayirish.** Berilgan yig'indi va qo'shiluvchilardan biriga ko'ra ikkinchi qo'shiluvchini topish amali natural sonlarni *ayirish* deyiladi.  $a$  va  $b$  natural sonlar uchun quyidagi tengliklar o'rinlidir, ya'ni

$$a - b = c \quad (2)$$

bo'lsa, u holda

$$a = b + c \quad (3)$$

bo'ladi. (2) tenglikda  $a$  natural son *kamayuvchi*,  $b$  - *ayriluvchi*,  $c$  esa *ayirma* deyiladi, bu yerda  $a$  son  $b$  sonidan katta.

M i s o l:  $45 - 30 = 15$  dan  $30 + 15 = 45$ ;  $123 - 85 = 38$  dan  $85 + 38 = 123$  bo'ladi.

Ayirish amali quyidagi xossalarga ega:

1)  $a - (b + c) = (a - b) - c$  yoki  $a - (b + c) = (a - c) - b$ , bu yerda  $a > b + c$  bo'lishi kerak.

M i s o l:  $148 - (16 + 34) = (148 - 16) - 34 = 132 - 34 = 98$  yoki  $(148 - 34) - 16 = 114 - 16 = 98$  bo'ladi.

$$2) (a + b) - c = \begin{cases} (a - c) + b, & \text{agar } a \geq c \text{ bo'lsa,} \\ a + (b - c), & \text{agar } b \geq c \text{ bo'lsa.} \end{cases}$$

M i s o l:  $(39 + 41) - 25 = (39 - 25) + 41 = 14 + 41 = 55$ ;

$$(18 + 56) - 43 = 18 + (56 - 43) = 18 + 13 = 31.$$

**3. Natural sonlarni ko'paytirish.** O'zaro teng bo'lgan qo'shiluvchilar yig'indisini topish amali *ko'paytirish* deyiladi va

$$\underbrace{a + a + a + \dots + a}_{n \text{ ta}} = a \cdot n \quad (4)$$

tenglik o'rinli bo'ladi.

M i s o l:  $17 + 17 + 17 + 17 + 17 = 17 \cdot 5 = 85$ .

Natural sonlarni ko'paytirish amali quyidagi xossalarga ega:

1)  $a \cdot b = b \cdot a$  (o'rin almashtirish).

M i s o l:  $108 \cdot 10 = 10 \cdot 108 = 1080$ .

2)  $(a \cdot b) \cdot c = a \cdot (b \cdot c)$  (guruhlash).

M i s o l:  $(15 \cdot 6) \cdot 20 = 15 \cdot (6 \cdot 20) = 1800$ .

3)  $(a \pm b) \cdot c = ac \pm bc$  (ko'paytirishning qo'shish va ayirishga nisbatan tarqatish (taqsimot) qonuni).

M i s o l: 1)  $(14 + 7) \cdot 5 = 14 \cdot 5 + 7 \cdot 5 = 70 + 35 = 105$ ;

2)  $(32 - 18) \cdot 10 = 32 \cdot 10 - 18 \cdot 10 = 320 - 180 = 140$ .

**4. Natural sonlarni bo'lish.** Ikki ko'paytuvchining ko'paytmasi va ko'paytuvchilardan biriga ko'ra ikkinchi ko'paytuvchini topish amali natural sonlarni *bo'lish* deyiladi. Agar  $a \cdot x = b$  (bu yerda  $x$  — noma'lum ko'paytiruvchi) bo'lsa, u holda

$$x = b : a \quad (5)$$

bo'ladi. (5) tenglikda  $b$  bo'linuvchi,  $a$  bo'luvchi,  $x$  bo'linma deyiladi.

M i s o l:  $40 \cdot x = 120$ , bundan  $x = 120 : 40 = 3$ ;  $x = 3$  bo'ladi.

Biror sonni boshqa bir songa bo'lishdan chiqqan bo'linma butun son (butun son tushunchasi II bob, 8-§ da berilgan) bo'lmasligi ham mumkin. Agar bo'linma butun son bo'lsa, bo'linuvchi son bo'luvchi songa *qoldiqsiz bo'linadi*, yoki qisqacha, *bo'linadi* deyiladi. Masalan, 21 soni 7 ga qoldiqsiz bo'linadi, chunki bo'linma 3 — butun son. Bunday hollarda bo'linuvchi bo'luvchining *karralisi* ham deyiladi.

Bo'linuvchi bo'luvchiga qoldiqsiz bo'linmagan holda *qoldikli bo'lish* amali bajariladi. Qoldikli bo'lish — bu bo'luvchiga ko'paytirganda bo'linuvchidan oshmaydigan son chiqadigan *to'liqsiz bo'linma* deb ataluvchi eng katta butun sonni topish demakdir. Bunda bo'linuvchidan bo'luvchi bilan to'liqsiz bo'linma ko'paytmasining ayirmasi *qoldiq* deb ataladi. Qoldiq hamma vaqt bo'luvchidan kichik bo'ladi.

Masalan, 23 soni 4 ga qoldiqsiz bo'linmaydi. Bu ikki son ustida qoldikli bo'lish amalini bajarish mumkin. Bundan to'liqsiz bo'linma 5 ga teng. Qoldiq  $23 - 4 \cdot 5 = 3$  ga teng.

Umuman,  $m$  va  $n$  ( $m > n$ ) sonlar berilgan bo'lsa,  $m$  ni  $n$  ga bo'lganda to'liqsiz bo'linma  $k$  ga, qoldiq  $r$  ga teng bo'lsa,

$$m = n \cdot k + r \quad (6)$$

tenglik o'rinlidir.

## 2-§. Sonlarning bo'linish belgilari

Bir sonning ikkinchi songa qoldiqsiz bo'linish yoki bo'linmasligini aniqlash uchun quyidagi bo'linish belgilarini yodda saqlash zarur:

1. Barcha juft sonlar 2 ga qoldiqsiz bo'linadi.

2. Raqamlarining yig'indisi 3 ga bo'linadigan sonlar 3 ga qoldiqsiz bo'linadi; raqamlarining yig'indisi 9 ga bo'linadigan sonlar 9 ga qoldiqsiz bo'linadi.

Misol: 1)  $3792 : 3 = 1264$  (raqamlar yig'indisi:  $3 + 7 + 9 + 2 = 21$ ); 2) 938655 soni 3 ga ham, 9 ga ham bo'linadi, chunki raqamlar yig'indisi:  $9 + 3 + 8 + 6 + 5 + 5 = 36$ .

3. Oxirgi ikki raqamidan iborat son 4 ga bo'linadigan sonlar yoki oxirgi ikki raqami nollardan iborat sonlar 4 ga bo'linadi.

Misol: 116; 364; 1096; 1700; 197204 va h.k. sonlar 4 ga qoldiqsiz bo'linadi, chunki ularning oxirgi ikki raqamidan iborat son 4 ga bo'linadi.

4. Oxirgi raqami 0 yoki 5 bilan tugagan barcha sonlar 5 ga qoldiqsiz bo'linadi.

Misol: 140; 1075; 89395; 729800 va h.k. sonlar.

5. Oxirgi uchta raqami nollar yoki 8 ga bo'linadigan sondan iborat sonlar 8 ga qoldiqsiz bo'linadi.

Misol: 1 000; 137 824; 3 278 064 va h.k. sonlar.

6. Ikkiga ham, uchga ham bo'linadigan sonlar 6 ga bo'linadi.

Misol: 378; 9 702; 48 684 va h.k. sonlar 6 ga qoldiqsiz bo'linadi.

7. Oxiri nol bilan tugagan sonlar 10 ga bo'linadi.

8. Son 11 ga bo'linishi uchun (o'ngdan chapga qarab hisoblaganda) toq o'rinda turgan raqamlar yig'indisi bilan juft o'rinda turgan raqamlar yig'indisining ayirmasi nolga teng yoki 11 ga bo'linsa, u holda bunday sonlar 11 ga bo'linadi.

Misollar: 1) 103 785 soni 11 ga bo'linadi, chunki uning toq xonalaridagi raqamlari yig'indisi  $1 + 3 + 8 = 12$ , juft xonalaridagi raqamlari yig'indisi  $0 + 7 + 5 = 12$ .

2) 9 163 627 soni 11 ga bo'linadi, chunki uning toq xonalaridagi raqamlari yig'indisi  $9 + 6 + 6 + 7 = 28$ , juft xonalaridagi raqamlari yig'indisi  $1 + 3 + 2 = 6$ ; bu ikki yig'indining ayirmasi  $28 - 6 = 22$ , bu son 11 ga bo'linadi.

3) 461 025 soni 11 ga bo'linmaydi;  $4 + 1 + 2 = 7$  va  $6 + 0 + 5 = 11$  sonlari o'zaro teng emas, ularning ayirmasi  $11 - 7 = 4$  ham 11 ga bo'linmaydi.

### 3-§. Tub va murakkab sonlar

**3.1. Natural sonlarning turlari.** Ta'rif.  $p > 1$  natural sonning 1 va o'zidan boshqa bo'luvchilari bo'lmasa, u holda  $p$  son tub son deyiladi. Boshqacha aytganda, sonning bo'luvchilari ikkitadan ortiq bo'lmasa, bunday sonlar tub sonlar deyiladi.

Ta'rif. Ikkitadan ortiq bo'luvchiga ega bo'lgan sonlar murakkab sonlar deyiladi.

Ta'rif. Berilgan son qoldiqsiz bo'linadigan natural sonlar uning bo'luvchilari deyiladi.

1 soni faqat bitta bo'luvchiga ega. Shuning uchun u tub songa ham, murakkab songa ham kirmaydi. Tub sonlar qatori cheksizdir:

$$2, 3, 5, 7, 11, 13, \dots, 101, \dots$$

12 murakkab son, chunki uning bo'luvchilari: 1, 2, 3, 4, 6 va 12 sonlari; 27 ning bo'luvchilari: 1, 3, 9 va 27 ning o'zidir.

**3.2. Berilgan natural sonlarning eng katta umumiy bo'luvchisi (EKUB).** Ta'rif. Berilgan sonlarning bo'luvchilari ichida eng kattasi ularning eng katta umumiy bo'luvchisi deyiladi va qisqacha EKUB deb belgilanadi.

$a$  va  $b$  natural sonlar bo'lsa, ularning eng katta umumiy bo'luvchisi  $EKUB(a; b) = m$  kabi belgilanadi, bu yerda  $m$  son  $a$  va  $b$  natural sonlarning eng katta umumiy bo'luvchisi. Masalan, 36 va 24 sonlarining eng katta umumiy bo'luvchisi 12, ya'ni  $EKUB(36; 24) = 12$ .

Umuman, berilgan sonlarning eng katta umumiy bo'luvchisi ularni tub ko'paytuvchilarga ajratish yo'li bilan topiladi. Bunda ularning tub ko'paytuvchilarga yoyilmalaridagi umumiy tub sonlar eng past daraja bilan olinib, so'ngra o'zaro ko'paytiriladi.

Misol: 234, 1080, 8100 sonlarining eng katta umumiy bo'luvchisini toping.

Berilgan sonlarni tub ko'paytuvchilarga ajratamiz:  $234 = 2 \cdot 3^2 \cdot 13$ ;  $1080 = 2^3 \cdot 3^3 \cdot 5$ ;  $8100 = 2^2 \cdot 3^4 \cdot 5^2$ .  $EKUB(234; 1080; 8100) = 2 \cdot 3^2 = 18$ .

**Ta'rif.** 1 dan boshqa umumiy bo'luvchiga ega bo'lmagan sonlar o'zaro tub sonlar deyiladi. Agar  $a$  va  $b$  natural sonlarning 1 dan boshqa bo'luvchilari bo'lmasa, ular o'zaro tub sonlar bo'lib, quyidagicha yoziladi:  $(a; b) = 1$ .

Masalan,  $(3; 5) = 1$ ;  $(11; 17) = 1$ ;  $(97; 101) = 1$ ;  $(14; 25) = 1$ .

$a$  va  $b$  sonlarning eng katta umumiy bo'luvchisini Evklid algoritmi bo'yicha ham topish mumkin. Bunda  $a$  son  $b$  songa bo'linganda biror  $r_1$  qoldiq qolsin, ya'ni  $a = q_1 b + r_1$ . So'ngra  $b$  son  $r_1$  qoldiqqa bo'linadi:

$$b = q_2 r_1 + r_2.$$

Yana  $r_1$  qoldiq  $r_2$  qoldiqqa bo'linadi:

$$r_1 = q_3 r_2 + r_3.$$

Shu usulni davom ettirib,  $r_{k-1} = q_k r_k$  ga ega bo'lamiz. Demak,  $\text{EKUB}(a; b) = \text{EKUB}(b; r_1) = \text{EKUB}(r_1; r_2) = \dots = \text{EKUB}(r_{k-1}; r_k)$ . Shunday qilib,  $\text{EKUB}(a; b) = \text{EKUB}(r_{k-1}; r_k) = r_k$ ; bu yerda  $r_k$  - shu  $a$  va  $b$  sonlarning eng katta umumiy bo'luvchisi.

**M i s o l:**  $\text{EKUB}(645; 381) = ?$

Y e c h i l i s h i:	$645 = 381 \cdot 1 + 264;$	$q_1 = 1; r_1 = 264.$
	$381 = 264 \cdot 1 + 117;$	$q_2 = 1; r_2 = 117.$
	$264 = 117 \cdot 2 + 30;$	$q_3 = 2; r_3 = 30.$
	$117 = 30 \cdot 3 + 27;$	$q_4 = 3; r_4 = 27.$
	$30 = 27 \cdot 1 + 3;$	$q_5 = 1; r_5 = 3.$
	$27 = 3 \cdot 9 + 0; (27; 3) = 3.$	

Demak,  $\text{EKUB}(645; 381) = 3$ .

**3.3. Berilgan natural sonlarning eng kichik umumiy karralisi (EKUK).** **Ta'rif.** Berilgan  $a, b, c, \dots, f$  natural sonlarning har biriga bo'linadigan eng kichik natural son shu sonlarning eng kichik umumiy karralisi (bo'linuvchisi) deyiladi va  $\text{EKUK}(a; b; c; \dots; f)$  kabi belgilanadi.

Agar  $a$  va  $b$  natural sonlar bo'lib, ularning eng kichik umumiy bo'linuvchisi  $m$  son bo'lsa, u holda  $\text{EKUK}(a; b) = m$  ko'rinishda yoziladi.

Masalan, 36 va 24 sonlarining eng kichik umumiy karralisini topaylik. Berilgan sonlarni tub ko'paytuvchilarga ajratamiz:

36	2	24	2	$36 = 2^2 \cdot 3^2;$
18	2	12	2	$24 = 2^3 \cdot 3.$
9	3	6	2	
3	3	3	3	
1		1		

Berilgan natural sonlarning eng kichik umumiy karralisi (EKUK) bu sonlarning tub ko'paytuvchilarga yoyilmasidagi bir xil tub ko'paytuvchilarning eng yuqori darajalilari va qolgan tub sonlarning ko'paytmasidan iborat:  $EKUK(36; 24) = 2^3 \cdot 3^2 = 8 \cdot 9 = 72$ .

**E s l a t m a.** Agar  $a, b, n$  natural sonlar berilgan bo'lib,  $a > b$  va  $a = n \cdot b$  bo'lsa,  $u$  holda  $EKUB(a; b) = b$ ,  $EKUK(a; b) = a$ .

**3.4. Murakkab sonning bo'luvchilari soni (BS).** Berilgan sonning bo'luvchilari sonini topish uchun uni tub ko'paytuvchilarga ajratiladi, so'ngra hosil bo'lgan yoyilmadagi tub sonlar darajalariga 1 qo'shiladi va hosil bo'lgan yig'indilar ko'paytiriladi.

Umuman,  $a = p_1^{\alpha_1} \cdot p_2^{\alpha_2} \cdot \dots \cdot p_n^{\alpha_n}$  bo'lsa,  $u$  holda  $a$  sonning bo'luvchilari soni  $(\alpha_1 + 1) \cdot (\alpha_2 + 1) \cdot \dots \cdot (\alpha_n + 1)$  ga teng bo'ladi va  $BS(a) = (\alpha_1 + 1) \cdot (\alpha_2 + 1) \cdot \dots \cdot (\alpha_n + 1)$  ko'rinishda yoziladi.

**M i s o l:** 72 ning bo'luvchilar sonini toping.

72 ni tub ko'paytuvchilarga ajratamiz:

72	2	$72 = 2^3 \cdot 3^2.$ U holda $BS(72) = (3 + 1) \cdot (2 + 1) = 12.$
36	2	
18	2	
9	3	
3	3	
1		

**3.5. Natural sonlarning umumiy bo'luvchilari soni (UBS).** Murakkab sonning bo'luvchilari soni (BS) shu sonning tub ko'paytuvchilari yoyilmasidan olinsa, bir nechta natural sonlarning umumiy bo'luvchilar soni (UBS) berilgan natural sonlarning eng katta umumiy bo'luvchisining tub ko'paytuvchilarga yoyilmasidan olinadi.

**M i s o l:** 18 va 54 sonlarining umumiy bo'luvchilari sonini toping.

Berilgan sonlarni tub ko'paytuvchilarga ajratamiz.

$$\begin{array}{l|l}
 18 & 2 \\
 9 & 3 \\
 3 & 3 \\
 1 & 3 \\
 & 1
 \end{array}
 \begin{array}{l|l}
 54 & 2 \\
 27 & 2 \\
 9 & 3 \\
 3 & 3
 \end{array}
 \begin{array}{l}
 \text{EKUB (18; 54) = } 2 \cdot 3^2 = 18. \\
 \text{U holda UBS (18; 24) = (1 + 1) \cdot (2 + 1) = 6.}
 \end{array}$$

### Mustaqil ishlash uchun test topshiriqlari

- 3 soat 15 minut 7 sekundda necha sekund bor?  
A) 12706; B) 11607; C) 11707; D) 11700; E) 11706.
- Hisoblang:  $73 \cdot 73 + 19 \cdot 73 + 73 \cdot 8$ .  
A) 6980; B) 7100; C) 7200; D) 7300; E) 7299.
- 456 va 544 sonlari yig'indisi bilan 435 va 275 sonlari ayirmasining ko'paytmasini hisoblang.  
A) 160200; B) 160000; C) 159800; D) 171000; E) 159000.
- Agar  $a + b + c + d = 108$  bo'lsa,  $(a + b) + (c + b) + (d + a) + (c + d)$  ifodaning qiymatini toping.  
A) 210; B) 215; C) 220; D) 200; E) 216.
- Bo'yi 2 m, eni 6 dm va balandligi 1 m bo'lgan idishga qancha suv sig'adi?  
A) 1300 l; B) 1500 l; C) 1200 l; D) 1100 l; E) 1250 l.
- Sonli ifodaning qiymatini toping:  
 $13 \cdot 67 + 82 \cdot 47 + 13 \cdot 33 + 18 \cdot 47$ .  
A) 5000; B) 5800; C) 6000; D) 5900; E) 7000.
- 1 dan 50 gacha bo'lgan barcha natural sonlarning ko'paytmasi nechta nol bilan tugaydi?  
A) 9; B) 13; C) 10; D) 12; E) 11.
- Ushbu 1234567891011...4950 sonining raqamlari yig'indisini toping.  
A) 330; B) 335; C) 320; D) 315; E) 310.
- Bo'linuvchi 8753, to'liqsiz bo'linma 116, qoldiq 53 ga teng bo'lsa, bo'luvchini toping.  
A) 70; B) 65; C) 80; D) 72; E) 75.

10. Farhod bir son o'yladi. So'ngra bu songa birni qo'shib, uni 2 ga ko'paytirdi. Ko'paytmani 3 ga bo'ldi va bo'linmadan 4 ni ayirdi. Natijada 6 hosil bo'ldi. U qanday son o'ylagan?

A) 12; B) 9; C) 14; D) 15; E) 16.

11. 1 dan 100 gacha bo'lgan natural sonlar orasida 2 ga ham, 3 ga ham bo'linmaydiganlari nechta?

A) 33; B) 30; C) 32; D) 21; E) 19.

12.  $\frac{n^2-12}{n}$  ( $n \in \mathbb{N}$ ) ifoda natural son bo'ladigan  $n$  ning barcha qiymatlari yig'indisini toping.

A) 20; B) 19; C) 22; D) 21; E) 24.

13. Quyidagi sonlardan qaysilari 12 ga qoldiqsiz bo'linadi?

A) 9216; B) 13626; C) 12014; D) 18313; E) 52318.

14.  $n$  raqamining qanday eng kichik natural qiymatida  $(147 + 3n^2)$  soni 3 ga qoldiqsiz bo'linadi?

A) 3; B) 2; C) 5; D) 1; E) 4.

15. 1) 1765402; 2) 908307; 3) 4583918 sonlarining qaysilari 3 ga ham, 9 ga ham qoldiqsiz bo'linadi?

A) 1; 3; B) 2; C) 1; D) 3; E) 2; 3.

16. 630 va 198 sonlarining umumiy bo'luvchilari nechta?

A) 5; B) 6; C) 4; D) 7; E) 8.

17. 108, 54, 81 va 324 sonlarining EKUBini toping.

A) 29; B) 36; C) 19; D) 27; E) 24.

18.  $n$  raqamining qanday eng kichik natural qiymatida  $\overline{32072n2}$  soni 11 ga qoldiqsiz bo'linadi?

A) 5; B) 3; C) 4; D) 2; E) 1.

19. 1960 va 588 sonlarining EKUBini toping.

A) 201; B) 192; C) 195; D) 196; E) 194.

20. 645 va 381 sonlarining EKUKini toping.

A) 8910; B) 81913; C) 81915; D) 81920; E) 81914.

21. O'zaro tub sonlar juftini ko'rsating.

A) (15; 36); B) (15; 26); C) (21; 27); D) (13; 39); E) (17; 51).

22. 925 soni nechta bo'luvchiga ega?

A) 3; B) 5; C) 6; D) 25; E) 2.

23. Uch xonali toq sonning o'nliklar xonasidagi son yuzliklar xonasidagi sondan 2 marta, birliklar xonasidagi sondan 6 marta katta. Shu sonni toping.



A) 361;    B) 481;    C) 243;    D) 126;    E) 488.

24. Ikki xonali sonning raqamlari yig'indisi 6 ga teng. Agar bu songa 18 qo'shilsa, raqamlari teskari tartibda yozilgan son hosil bo'ladi. Shu sonni toping.

A) 42;    B) 51;    C) 24;    D) 33;    E) 15.

25. Ikki xonali son raqamlarining ko'paytmasi raqamlar yig'indisidan ikki marta katta. Agar shu ikki xonali sondan 27 soni ayirilsa, berilgan son raqamlari teskari tartibda yozilgan son hosil bo'ladi. Berilgan sonni toping.

A) 63;    B) 73;    C) 53;    D) 36;    E) 68.

## RATSIONAL SONLAR VA IRRATSIONAL SONLAR

### 1-§. Oddiy kasrlar

**Ta'rif.** Butunning (birlikning) bir yoki bir necha teng bo'lagini (ulushini) ifodalovchi son *kasr son* deb ataladi. Kasr son  $\frac{m}{n}$ ,  $\frac{a}{b}$ ,  $\frac{p}{q}$  (bu yerda  $m, a, p$  – butun sonlar (II bob, 8-§),  $n, b, q$  – natural sonlar) kabi belgilanadi. Butunni nechta teng bo'lakka bo'linganligini ifodalovchi  $n, b, q$  sonlar kasrning *maxraji*, nechta bo'lagi olinganini ifodalovchi  $m, a, p$  sonlar kasrning *surati* deyiladi.

$\frac{2}{3}$ ,  $\frac{31}{28}$ ,  $\frac{131}{179}$  va h.k. lar kasr sonlardir.

**1.1.** Agar kasrning surati maxrajidan kichik bo'lsa, bunday kasr *to'g'ri kasr* deyiladi.  $\frac{7}{13}$ ,  $\frac{91}{105}$ ,  $\frac{1299}{1387}$  to'g'ri kasrlardir.

**1.2.** Agar kasrning maxraji suratidan kichik yoki teng bo'lsa, bunday kasr *noto'g'ri kasr* deyiladi.  $\frac{15}{11}$ ,  $\frac{89}{73}$ ,  $\frac{139}{139}$ ,  $\frac{873}{765}$  noto'g'ri kasrlardir.

**1.3.** Har qanday noto'g'ri kasrdan uning butun qismini ajratish mumkin.  $\frac{27}{12} = 2\frac{3}{12}$ ;  $\frac{483}{376} = 1\frac{107}{376}$ .

**1.4.** Butun son va to'g'ri kasrning yig'indisidan iborat kasr *aralash kasr* deyiladi.  $3\frac{3}{4}$ ,  $12\frac{1}{3}$ ,  $108\frac{110}{111}$  kabilar aralash kasrlar.

Aralash kasrni noto'g'ri kasrga aylantirish uchun uning butun qismini maxrajga ko'paytirib va bu ko'paytmaga suratni qo'shib, suratga yozish, maxrajni esa o'zgarishsiz qoldirish kerak.

$$\frac{3}{5} = \frac{5 \cdot 5 + 3}{5} = \frac{28}{5}; \quad 12\frac{1}{4} = \frac{12 \cdot 4 + 1}{4} = \frac{49}{4}.$$

## 2-§. Oddiy kasrlar ustida arifmetik amallar

Oddiy kasr quyidagi asosiy xossaga ega:

*kasrning surat va maxrajini noldan farqli songa ko'paytirilsa yoki bo'linsa, kasrning qiymati o'zgarmaydi.*

Agar  $a$ ,  $b$  va  $n$  natural sonlar bo'lsa, u holda  $\frac{a}{b} = \frac{na}{nb}$ ,  $\frac{na}{nb} = \frac{a}{b}$  bo'ladi.

Misol:  $\frac{3}{5} = \frac{3 \cdot 4}{5 \cdot 4} = \frac{12}{20}$ ;  $\frac{30}{45} = \frac{15 \cdot 2}{15 \cdot 3} = \frac{2}{3}$ . Demak, berilgan kasrga teng kasrlar cheksiz ko'pdir.

2.1. Maxrajleri bir xil kasrlarni qo'shish (ayirish) uchun ularning suratlarini qo'shib (ayirib) suratga yozish va maxrajni o'zgarishsiz qoldirish kerak.

Misol: 1)  $\frac{5}{8} + \frac{2}{8} = \frac{5+2}{8} = \frac{7}{8}$ ; 2)  $\frac{15}{19} + \frac{3}{19} = \frac{15+3}{19} = \frac{18}{19}$ ;

3)  $2\frac{11}{37} + 11\frac{9}{37} = 13\frac{11+9}{37} = 13\frac{20}{37}$ ; 4)  $\frac{17}{25} - \frac{11}{25} = \frac{17-11}{25} = \frac{6}{25}$ ;

5)  $8\frac{13}{14} - 5\frac{8}{14} = 3\frac{13-8}{14} = 3\frac{5}{14}$ .

2.2. Har xil maxrajli oddiy kasrlarni qo'shish (ayirish) ularning maxrajlarini umumiy maxrajga keltirib, ya'ni maxrajlarining EKUKni topib, so'ngra bir xil maxrajli kasrlarni qo'shish (ayirish) kabi bajariladi.

Misol: 1)  $\frac{7}{12} + \frac{3}{5} = \frac{7 \cdot 5}{60} + \frac{3 \cdot 12}{60} = \frac{35+36}{60} = \frac{71}{60} = 1\frac{11}{60}$ ;

2)  $5\frac{4}{9} + 12\frac{3}{5} = 5\frac{20}{45} + 12\frac{27}{45} = 17\frac{20+27}{45} = 17\frac{47}{45} = 18\frac{2}{45}$ ;

3)  $\frac{6}{7} - \frac{11}{35} = \frac{30}{35} - \frac{11}{35} = \frac{30-11}{35} = \frac{19}{35}$ ;

4)  $6\frac{12}{13} - 3\frac{3}{4} = 6\frac{48}{52} - 3\frac{39}{52} = 3\frac{48-39}{52} = 3\frac{9}{52}$ .

**2.3.** Oddiy kasrlarni ko'paytirish uchun ularning suratlarini ko'paytirib, kasrning suratiga, maxrajlarini ko'paytirib maxrajga yozish kerak. Aralash kasrlar bo'lsa, ularni noto'g'ri kasrga aylantirib, so'ngra ko'paytirish kerak.

$$\text{Misol: } 1) \frac{7}{15} \cdot \frac{5}{21} = \frac{\overset{1}{7} \cdot \overset{1}{5}}{\underset{3}{15} \cdot \underset{3}{21}} = \frac{1}{9}; \quad 2) 3\frac{3}{4} \cdot 1\frac{1}{3} = \frac{\overset{5}{15} \cdot \overset{1}{4}}{\underset{1}{4} \cdot \underset{1}{3}} = 5;$$

$$2) 39 \cdot 2\frac{5}{13} = \frac{\overset{3}{39} \cdot \overset{31}{31}}{\underset{1}{13}} = 93.$$

**2.4.** Oddiy kasrlarni bo'lish uchun birinchi kasrni ikkinchi kasrning teskarisiga ko'paytirish kerak. Agar aralash kasrlar bo'lsa, ularni noto'g'ri kasrga aylantirib, so'ngra bo'lishni bajarish kerak.

$$\text{Misol: } 1) \frac{5}{6} : \frac{2}{3} = \frac{\overset{1}{5} \cdot \overset{3}{3}}{\underset{2}{6} \cdot \underset{2}{2}} = \frac{5}{4} = 1\frac{1}{4};$$

$$2) 8\frac{3}{4} : 1\frac{4}{17} = \frac{\overset{35}{35} \cdot \overset{17}{17}}{\underset{4}{4} \cdot \underset{3}{21}} = \frac{5 \cdot 17}{4 \cdot 3} = \frac{85}{12} = 7\frac{1}{12}.$$

**2.5.** Sonli ifodalarning qiymatini hisoblaganda birinchi navbatda arifmetik amallarning bajarilish tartibiga amal qilish kerak:

a) agar ifoda qavslarga ega bo'lmasa, u holda avvalo ikkinchi bosqich amallar, ya'ni ko'paytirish va bo'lish amallari, so'ngra birinchi bosqich amallar, ya'ni qo'shish va ayirish amallari bajariladi;

b) agar ifodada qavslar bo'lsa, avval qavs ichidagi amallar bajariladi. Qavslar ketma-ket joylashgan bo'lsa, amallar eng kichik qavsdan boshlab tartib bilan bajariladi.

Misol: 1)  $\frac{3}{4} : \frac{5}{6} + 2\frac{1}{2} \cdot \frac{2}{5} - 1 : 1\frac{1}{9}$  ifodaning qiymatini toping.

$$\text{Yechilishi: } 1) 2\frac{1}{2} \cdot \frac{2}{5} = \frac{\overset{3}{5} \cdot \overset{2}{2}}{\underset{2}{2} \cdot \underset{5}{5}} = 1; \quad 2) \frac{3}{4} : \frac{5}{6} = \frac{\overset{3}{3} \cdot \overset{6}{6}}{\underset{4}{4} \cdot \underset{5}{5}} = \frac{9}{10};$$

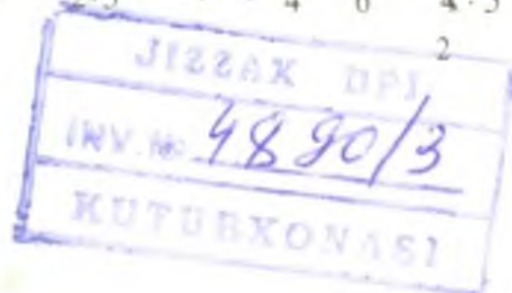

$$3) 1 : 1\frac{1}{9} = \frac{1 \cdot 9}{10} = \frac{9}{10}; 4) \frac{9}{10} + 1 - \frac{9}{10} = 1.$$

Javob: 1.

$$2) 2\frac{3}{4} : \left(1\frac{1}{2} - \frac{2}{5}\right) + \left(\frac{3}{4} + \frac{5}{6}\right) : 3\frac{1}{6} \text{ ning qiymatini toping.}$$

Yechilishi: 1)  $1\frac{1}{2} - \frac{2}{5} = \frac{5-4}{10} = 1\frac{1}{10}$  2)  $2\frac{3}{4} : 1\frac{1}{10} = \frac{11 \cdot 10}{4 \cdot 11} =$   
 $= \frac{5}{2} = 2\frac{1}{2}$ ; 3)  $\frac{3}{4} + \frac{5}{6} = \frac{9+10}{12} = \frac{19}{12} = 1\frac{7}{12}$ ;

$$4) 1\frac{7}{12} : 3\frac{1}{6} = \frac{19 \cdot 6}{12 \cdot 19} = \frac{1}{2}; 5) 2\frac{1}{2} + \frac{1}{2} = 3.$$

Javob: 3.

## 2.6. Ko'paytmasi 1 ga teng bo'lgan sonlar o'zaro teskari sonlar

deyiladi. Masalan.  $\frac{a}{b}$  va  $\frac{b}{a}$  sonlar o'zaro teskari sonlardir, chunki

$\frac{a}{b} \cdot \frac{b}{a} = 1$  bo'ladi.  $\frac{17}{43}$  va  $2\frac{9}{17}$  sonlari o'zaro teskari sonlardir, chunki,

$$\frac{17}{43} \cdot 2\frac{9}{17} = \frac{17}{43} \cdot \frac{43}{17} = 1.$$

## 2.7. Nol bilan amallar:

$$1) 5 + 0 = 5; 4\frac{3}{7} + 0 = 4\frac{3}{7}; 2) 13 - 0 = 13; 8\frac{2}{5} - 0 = 8\frac{2}{5};$$

$$3) 7 \cdot 0 = 0; 0 \cdot 6\frac{7}{9} = 0; 0 \cdot 0 = 0; 4) 0 : 19 = 0; 0 : \frac{111}{315} = 0.$$

5) Nolni nolga bo'lishdan chiqqan bo'linma n o a n i q d i r .

6) Noldan farqli biror sonni nolga bo'lishdan chiqadigan bo'linma mavjud emas, chunki bu holda bo'linmaning ta'rifini hech qanday son qanoatlantirmaydi.

### 3-§. O'nli kasrlar va ular ustida amallar

Ta'rif. *Oddiy kasrning maxraji 10 ning darajalaridan iborat bo'lsa, u o'nli kasr deb ataladi.*

Umuman, 10 ning natural ko'rsatkichli darajasi  $10^n (n \in \mathbb{N})$  ko'rinishda yoziladi:  $10^1 = 10$ ,  $10^2 = 100$ ,  $10^3 = 1000$  va hokazo.

Ta'rifga ko'ra  $\frac{7}{10} = 0,7$ ,  $\frac{39}{100} = 0,39$ ,  $\frac{789}{1000} = 0,789$ .

$\frac{12435}{1000} = 12,435$  kabi kasrlar o'nli kasrlardir.

**3.1.** O'nli kasrni oddiy kasr ko'rinishida yozish uchun uning butun qismini oddiy kasrning butun qismi sifatida yozib (o'nli kasrning butun qismi nol bo'lsa, u yozilmaydi), kasrning suratiga verguldan keyin turgan son yoziladi, maxrajiga esa 1 yozilib, u verguldan o'ng tomonda qancha raqam bo'lsa, shuncha nol bilan to'ldiriladi. Hosil bo'lgan oddiy kasrning surati va maxrajiga yozilgan sonlar eng katta umumiy bo'luvchiga ega bo'lsa, ularni unga qisqartirish kerak. Masalan,

$$0,75 = \frac{75}{100} = \frac{3}{4}; \quad 4,18 = 4 \frac{18}{100} = 4 \frac{9}{50} \quad \text{va h.k.}$$

**3.2.** Oddiy kasrni o'nli kasrga aylantirish uchun uning suratini maxrajiga bo'lish kerak. Bunda chekli yoki cheksiz o'nli kasr hosil bo'ladi.

Agar oddiy kasr maxrajining tub sonlardan iborat yoyilmasi faqat 2 dan, 5 dan yoki faqat 2 yoki 5 dan iborat bo'lsa, bunday oddiy kasrni chekli o'nli kasr ko'rinishida yozish mumkin. Masalan,

$$\frac{1}{8} = 0,125; \quad \frac{13}{25} = 0,52; \quad \frac{17}{4} = 4,25; \quad 15 \frac{3}{8} = 15,375; \quad \frac{173}{50} = 3,46.$$

Agar oddiy kasr maxrajining tub sonlardan iborat yoyilmasidan 2 va 5 dan boshqa tub sonlar ham bo'lsa, u holda bunday o'nli kasrlar cheksiz o'nli kasrlarga aylanadi. Masalan,

$$\frac{8}{15} = 0,53333\dots; \quad \frac{2}{3} = 0,6666\dots; \quad \frac{17}{14} = 1,21428571\dots$$

**3.3.** O'nli kasrlarni qo'shish va ayirish natural sonlarni qo'shish va ayirish kabi bajariladi, bunda faqat qo'shiluvchilarning bir xil xona birliklarini bir-birining tagiga ustun shaklida to'g'ri yozilishiga e'tibor berish kerak.

Misollar: 1) 
$$\begin{array}{r} 0,7389 \\ + 0,4075 \\ \hline 1,1464 \end{array}$$
 2) 
$$\begin{array}{r} 13,083 \\ + 6,3574 \\ \hline 19,4404 \end{array}$$
 3) 
$$\begin{array}{r} 0,8354 \\ - 0,5648 \\ \hline 0,2706 \end{array}$$

4) 
$$\begin{array}{r} 8,14507 \\ - 5,75214 \\ \hline 2,39293 \end{array}$$
 5) 
$$\begin{array}{r} 33,3 \\ - 6,456 \\ \hline 26,844 \end{array}$$
 6) 
$$\begin{array}{r} 119,724 \\ - 65,3 \\ \hline 54,424 \end{array}$$

**3.4. O'nli kasrni o'nli kasrga ko'paytirish uchun ularning vergul-lariga e'tibor qilmay, natural sonlarni ko'paytirish kabi ko'paytirish va natijada o'ngdan chapga qarab, ko'paytuvchilarning nechta kasr xonasi bo'lsa, shuncha raqam qoldirib, vergul qo'yish kerak.**

Misollar: 1) 
$$\begin{array}{r} 3,8 \\ \times 5,7 \\ \hline 266 \\ + 190 \\ \hline 21,66 \end{array}$$
 2) 
$$\begin{array}{r} 0,39 \\ \times 8,1 \\ \hline 39 \\ + 312 \\ \hline 3,159 \end{array}$$

**3.5. O'nli kasrni natural songa bo'lish uchun uning butun qismini bo'lish, agar butun qismi bo'luvchidan kichik bo'lsa, bo'linmaning butun qismiga nol yozib, so'ngra vergul qo'yiladi va bo'lishni natural sonlarni bo'lish kabi bajariladi.**

Misollar: 1) 
$$\begin{array}{r} 13,28 \overline{)64} \\ \underline{128} \quad 0,2075 \\ \quad \underline{480} \\ \quad \quad \underline{448} \\ \quad \quad \quad \underline{320} \\ \quad \quad \quad \quad \underline{320} \\ \quad \quad \quad \quad \quad \underline{0} \end{array}$$
 2) 
$$\begin{array}{r} 542,8 \overline{)16} \\ \underline{48} \quad 33,925 \\ \quad \underline{62} \\ \quad \quad \underline{48} \\ \quad \quad \quad \underline{148} \\ \quad \quad \quad \quad \underline{144} \\ \quad \quad \quad \quad \quad \underline{40} \\ \quad \quad \quad \quad \quad \quad \underline{32} \\ \quad \quad \quad \quad \quad \quad \quad \underline{80} \\ \quad \quad \quad \quad \quad \quad \quad \quad \underline{80} \\ \quad \quad \quad \quad \quad \quad \quad \quad \quad \underline{0} \end{array}$$

3.6. O'nli kasrni (butun sonni) o'nli kasrga bo'lish uchun bo'luvchidagi vergulni tashlab yuboramiz va uning kasr qismida necha xona bo'lsa, bo'linuvchida vergulni o'ngga shuncha xona suramiz va so'ngra bo'lishni yuqoridagidek bajaramiz.

Misollar:

$$\begin{array}{r}
 1) \quad \begin{array}{r} 0,0456,9 \\ \underline{36} \\ 96 \\ \underline{96} \\ 090 \\ \underline{84} \\ 60 \\ \underline{60} \\ 0 \end{array} \quad \begin{array}{r} 0,0012 \\ \underline{38,075} \end{array} \quad 2) \quad \begin{array}{r} 29,7,5 \\ \underline{272} \\ 255 \\ \underline{204} \\ 510 \\ \underline{476} \\ 340 \\ \underline{340} \\ 0 \end{array} \quad 3) \quad \begin{array}{r} 0,6,25 \\ \underline{50} \\ 125 \\ \underline{125} \\ 0 \end{array} \quad \begin{array}{r} 2,5 \\ \underline{0,25} \end{array}
 \end{array}$$

#### 4-§. Davriy o'nli kasrlar

Oddiy kasrlarni o'nli kasrga aylantirganda ayrim hollarda verguldan keyin bir yoki bir necha raqamlar guruhi davriy ravishda takrorlanadi. Bunday cheksiz o'nli kasrlar *davriy o'nli kasrlar* deyiladi. Takrorlanuvchi raqam yoki raqamlar majmuasi *davr* deyiladi.

Misollar: 1)  $\frac{1}{3} = 0,333$ ; 2)  $\frac{8}{3} = 2\frac{2}{3} = 2,666\dots$ ;

3)  $\frac{10}{6} = 1,666\dots$ ; 4)  $\frac{32}{15} = 2\frac{2}{15} = 2,1333\dots$

Davriy o'nli kasrlarni davrdagi raqamlarni qavs ichiga olinib, bunday yoziladi:

Misollar:  $0,333\dots = 0,(3)$ ;  $2,666\dots = 2,(6)$ ;  $2,1333\dots = 2,1(3)$ .

Davriy o'nli kasrlar ikki xil bo'ladi: a) agar davr verguldan keyin boshlansa, bunda davriy kasr *sof davriy kasr* deyiladi.

Misollar:  $3,1313\dots$ ;  $0,231231\dots$  lar sof davriy kasrlardir.

b)  $5,12777\dots$ ;  $0,42888\dots$ ;  $11,017373\dots$  ko'rinishdagi davriy kasrlar (verguldan keyin davrgacha raqamlar bor) *aralash davriy kasrlar* deyiladi.



Sof davriy kasrni oddiy kasrga aylantirish uchun uning butun qismini butunga, davrdagi sonni suratga, maxrajga esa davrda nechta raqam bo'lsa, shuncha 9 raqamini yozish kerak.

$$\text{Misollar: } 1) 0,(12) = \frac{12}{99} = \frac{4}{33}; \quad 2) 3,(132) = 3\frac{132}{999} = 3\frac{44}{333}.$$

Aralash davriy kasrni oddiy kasrga aylantirish uchun vergulga e'tibor bermay, ikkinchi davrgacha bo'lgan sondan birinchi davrgacha bo'lgan sonni ayirib, ayirmani suratga yozish, maxrajga esa, davrda nechta raqam takrorlansa, shuncha 9 raqami va uning yoniga birinchi davrgacha nechta raqam bo'lsa, shuncha nol yozish kerak.

$$\text{Misollar: } 1) 0,3(7) = \frac{37-3}{90} = \frac{34}{90} = \frac{17}{45};$$

$$2) 1,8(11) = 1\frac{811-8}{990} = 1\frac{803}{990}.$$

### 5-§. Oddiy va o'nli kasrlar qatnashgan sonli ifodalarning qiymatlarini hisoblash

Sonli ifodalar qiymatlarini hisoblashda, odatda, arifmetik amallarni bajarilish tartibiga qat'iy rioya qilinadi. Agar sonli ifodada oddiy kasrlar ham, o'nli kasrlar ham qatnashayotgan bo'lsa, dastavval, oddiy kasrlarni tahlil qilib ko'rish, ularni 3.2-banda bayon qilingan qoida asosida chekli o'nli kasrga aylantirish mumkin bo'lsa, amallarni o'nli kasrlarda bajarish ifodalarning qiymatlarini hisoblashni ancha yengillashtiradi.

$$\text{1-misol. } 3,5 \cdot \left( \left( 16,875 - \frac{2}{3} \cdot 1\frac{5}{16} \right) - \left( 0,55 + 8\frac{4}{5} \right) \right) \cdot 100$$

sonli ifodaning qiymatini hisoblash.

$$\text{Yechilishi: } 1) \text{ Modullarini } \frac{2}{3} \cdot 1\frac{5}{16} \text{ va } 8\frac{4}{5} \text{ o'nli kasrga aylantirishda}$$

hisoblashda yozamiz:

$$\frac{2}{3} \cdot 1\frac{5}{16} = \frac{2}{3} \cdot \frac{21}{16} = \frac{14}{16} = 0,875.$$

2)  $8\frac{4}{5}$  oddiy kasrni o'nli kasrga aylantiramiz:  $8\frac{4}{5} = 8,8$ .

Berilgan sonli ifoda o'rniga quyidagi ifodani hosil qildik:

$$3,5 \cdot ((16,875 - 0,875) - (0,35 + 8,8)) \cdot 100.$$

Uning qiymatini hisoblaymiz:

$$3,5 (16 - 9,15) \cdot 100 = 350 - 6,85 = 2397,5.$$

J a v o b: 2397,5.

Ayrim sonli ifodalarning qiymatlarini hisoblashda ko'rsatilgan amallarni ketma-ket bajarish o'rniga dastlab berilgan ifodani diqqat bilan qarab chiqib, tejamliroq, hisoblash ishlarini osonlashtiradigan ketma-ketlikni ishlatgan ma'qul.

2-m i s o l. 
$$\frac{(13,75 + 9\frac{1}{6}) \cdot 1,2}{(10,3 - 8\frac{1}{2}) \cdot \frac{5}{9}} + \frac{(6,8 - 3\frac{3}{5}) \cdot 5\frac{5}{6}}{(3\frac{2}{3} - 3\frac{1}{6}) \cdot 56} = 27\frac{1}{6}$$
 ifodaning

qiymatini toping.

Y e c h i l i s h i: Bu yerda birinchi kasr suratidagi ifodani hisoblashda qavs ichidagi o'nli kasrni oddiy kasrga aylantirib, qo'shish amalini bajarib, qavs ichida hosil bo'lgan qiymatni 1,2 ga ko'paytirgandan ko'ra qavs ichidagi har bir qo'shiluvchini 1,2 ga ko'paytirib, so'ngra yig'indini hisoblagan ma'qul.

1)  $(13,75 + 9\frac{1}{6}) \cdot 1,2 = 13,75 \cdot 1,2 + \frac{55}{6} \cdot 1,2 = 16,5 + 55 \cdot 0,2 = 27,5$ .

Berilgan kasr maxrajida qavs ichidagi yig'indini o'nli kasrlarda hisoblaymiz:

2)  $(10,3 - 8\frac{1}{2}) \cdot \frac{5}{9} = (10,3 - 8,5) \cdot \frac{5}{9} = 1,8 \cdot \frac{5}{9} = 0,2 \cdot 5 = 1$ .

3) Ikkinchi kasr surat va maxrajini hisoblaymiz:

$$(6,8 - 3\frac{3}{5}) \cdot 5\frac{5}{6} = (6,8 - 3,6) \cdot \frac{35}{6} = 3,2 \cdot \frac{35}{6} = \frac{16}{8} \cdot \frac{35}{6} = \frac{56}{3}$$

$$(3\frac{2}{3} - 3\frac{1}{6}) \cdot 56 = \frac{4-1}{6} \cdot 56 = \frac{1}{2} \cdot 56 = 28.$$

Shunday qilib, berilgan ifodaning qiymati

$$\frac{27,5}{1} + \frac{56}{3} \cdot \frac{1}{28} = 27\frac{1}{6}$$

ifodaning qiymatini hisoblashga keltirildi. Uni hisoblaymiz:

$$27\frac{1}{2} + \frac{2}{3} - 27\frac{1}{6} = \frac{1}{2} - \frac{1}{6} + \frac{2}{3} = \frac{3-1+4}{6} = \frac{6}{6} = 1.$$

Javob: 1.

3-misol:  $\frac{\left(\frac{5}{8} + 2,708(3)\right) : 2,5}{(1,3 + 0,7(6) + 0,(36)) \cdot \frac{110}{401}} \cdot \frac{1}{2}$  ifodaning qiymatini

hisoblang.

Yechilishi. Dastavval, davriy o'nli kasrlarni oddiy kasrga aylantirib, so'ngra ifodaning qiymatini hisoblaymiz:

$$\left[ \begin{array}{l} 2,708(3) = \frac{27083 - 2708}{9000} = \frac{24375}{9000} = \frac{65}{24}; \quad 0,7(6) = \frac{76-7}{90} = \frac{69}{90} = \frac{23}{30} \\ 0,(36) = \frac{36}{99} = \frac{4}{11} \end{array} \right]$$

$$\frac{\left(\frac{5}{8} + \frac{65}{24}\right) : 2,5}{\left(1,3 + \frac{23}{30} + \frac{4}{11}\right) \cdot \frac{110}{401}} \cdot \frac{1}{2} = \frac{\frac{80}{24} + \frac{2}{5}}{\frac{429 + 253 + 120}{330} \cdot \frac{110}{401}} \cdot \frac{1}{2} = \frac{4}{3} \cdot \frac{330}{802} \cdot \frac{401}{110} \cdot \frac{1}{2} = 1.$$

Javob: 1.

## 6-§. Nisbat va proporsiya. Protsent

**6.1. Ta'rif.** *a sonning b songa nisbati deb a sonni b songa bo'lishdan hosil bo'lgan bo'linmaga aytiladi va quyidagicha yoziladi:*

$\frac{a}{b} = a : b = m$ . Bunda *a nisbatning oldingi hadi, b keyingi hadi, m esa nisbat deyiladi.*

Misol.  $15 : 25 = \frac{15}{25} = \frac{3}{5} = 3 : 5$ .

Nisbat bu bir sonning (miqdorning) ikkinchi sondan (miqdordan) necha marta ortiq yoki kamligini ifodalaydi.

**Nisbat quyidagi xossaga ega:** agar nisbatning oldingi va keyingi hadini bir vaqtda noldan farqli songa ko'paytirilsa yoki bo'linsa, u holda nisbatning qiymati o'zgarmaydi.

Misollar.  $\frac{3}{4} = \frac{3 \cdot 5}{4 \cdot 5} = \frac{15}{20}$ ;  $\frac{48}{64} = \frac{48 : 16}{64 : 16} = \frac{3}{4} = 3 : 4$ .

**6.2. Ta'rif.** Ikki miqdordan birining  $k$  marta ortishi (kamayishi) bilan ikkinchisi ham  $k$  marta ortsa (kamaysa), ular to'g'ri proporsional miqdorlar deyiladi.

Agar  $\frac{y}{x} = k$  bo'lsa, u holda  $y = kx$  bo'ladi. Bu yerda  $k$  – proporsionallik koeffitsiyenti deyiladi.

**Sonni berilgan sonlarga to'g'ri proporsional bo'laklarga bo'lish uchun uni berilgan sonlar yig'indisiga bo'lish, so'ngra natijani berilgan sonlarning har biriga ko'paytirish kerak.**

**M a s a l a.** Uzunligi 81 sm bo'lgan kesmani 4 : 5 nisbatda bo'ling.

Yechilishi. 1)  $4 + 5 = 9$ ; 2)  $\frac{81}{9} \cdot 4 = 36$  3)  $\frac{81}{9} \cdot 5 = 45$  sm.

J a v o b: 36 sm; 45 sm.

**6.3. Ta'rif.** Agar ikki miqdordan birining ortishi (kamayishi) bilan ikkinchisi kamaysa (ortsa), u holda bunday miqdorlar teskari proporsional miqdorlar deyiladi.

Bunday miqdorlar ko'paytmasi o'zgarmas bo'ladi. Agar  $xy = k$  bo'lsa, bundan  $y = \frac{k}{x}$ .

Masalan, poyezdning ikki shahar orasidagi masofani bosib o'tishi uchun ketgan vaqti poyezd tezligiga teskari proporsionaldir. Agar poyezd 40 km/soat tezlik bilan yursa, Toshkent va Urganch shaharlari orasidagi masofani 25 soatda, 50 km/soat tezlik bilan yursa, 20 soatda bosib o'tadi. Demak, tezlik  $\frac{50}{40} = \frac{5}{4}$  nisbatda ortsa, masofani bosib o'tish uchun ketgan vaqt xuddi shu  $\frac{5}{4}$  nisbatda kamayadi.

**Sonni berilgan sonlarga teskari proporsional bo'laklarga bo'lish uchun bu sonni berilgan sonlarga teskari sonlarga to'g'ri proporsional bo'laklarga bo'lish yetarlidir.**

**M a s a l a:** 27 sonini 4 va 5 sonlariga teskari proporsional bo'laklarga bo'ling.

Yechilishi. Berilgan sonlarga teskari sonlar  $\frac{1}{4}$  va  $\frac{1}{5}$  bo'lib, ular  $\frac{1}{4} : \frac{1}{5} = \frac{5}{4}$  nisbatdadir. Demak, 5 : 4 nisbatda to'g'ri proporsional bo'laklarga bo'lamiz:

$$1) \frac{27}{9} \cdot 5 = 15; \quad 2) \frac{27}{9} \cdot 4 = 12.$$

Javob: 15 va 12.

**6.4. Ta'rif.** *Bir-biriga teng bo'lgan ikki nisbat tengligi proporsiya deyiladi.* Agar  $\frac{a}{b} = k$  va  $\frac{c}{d} = k$  bo'lsa, u holda  $\frac{a}{b} = \frac{c}{d}$  yoki  $a : b = c : d$  bo'ladi.  $a$  va  $d$  proporsiyaning *chetki hadlari*,  $b$  va  $c$  *o'rta hadlari* deyiladi.

Misol.  $12 : 15 = 4 : 5$  va  $48 : 60 = 4 : 5$ . Demak,  $12 : 15 = 48 : 60$ .

Proporsiya quyidagi xossalarga ega:

a) Chetki hadlar ko'paytmasi o'rta hadlar ko'paytmasiga, o'rta hadlar ko'paytmasi chetki hadlar ko'paytmasiga teng.

Misol.  $16 : 4 = 4 : 1$  dan  $16 \cdot 1 = 4 \cdot 4$ ;  $16 = 16$ .

Umuman,  $a : b = c : d$  bo'lsa, bundan  $ad = bc$  bo'ladi.

b) proporsiyaning chetki yoki o'rta hadlarining o'rinlarini almashtirish bilan uning qiymati o'zgarmaydi.

Misol.  $7 : 3 = 28 : 12$  dan  $7 : 28 = 3 : 12$  yoki  $12 : 3 = 28 : 7$

d) Proporsiyaning chetki hadi noma'lum bo'lsa, uni topish uchun o'rta hadlar ko'paytmasini ma'lum chetki hadga bo'lish kerak. O'rta had noma'lum bo'lsa, chetki hadlar ko'paytmasini ma'lum o'rta hadga bo'lish kerak.

$$\begin{aligned} \text{Misollar. } 1) \quad x : 0,48 &= 3 \frac{3}{4} : 1,4; \quad x = 0,48 \cdot 3 \frac{3}{4} : 1,4 = \\ &= \frac{12 \cdot 15 \cdot 5}{25 \cdot 4 \cdot 7} = \frac{9}{7}; \quad x = 1 \frac{2}{7}; \quad 2) \quad 3 \frac{3}{35} : \frac{2}{3} x = 7,2 : 1 \frac{5}{9}; \quad \frac{2}{3} x \cdot 7,2 = \\ &= 3 \frac{3}{35} \cdot 1 \frac{5}{9}; \quad 4,8x = \frac{24}{5}; \quad x = \frac{24}{4 \cdot 8 \cdot 5} = \frac{24}{24} = 1. \end{aligned}$$

g) Hosilaviy proporsiyalar.  $a : b = c : d$  bo'lsa, u holda  $\frac{a+b}{b} = \frac{c+d}{d}$ ;  $\frac{a-b}{b} = \frac{c-d}{d}$ ;  $\frac{a+b}{a-b} = \frac{c+d}{c-d}$  bo'ladi.

Misol.  $\frac{3}{2} = \frac{12}{8}$  dan  $(3+2):2 = (12+8):8$ ;  $(3-2):2 = (12-8):8$  va h.k.

**6.5. Protsent.** Har qanday sonning (miqdorning) yuzdan bir bo'lagi (ulushi) shu sonning *bir protsenti* deb ataladi. Protsent so'zi lotincha "procentum" so'zidan olingan bo'lib, yuzdan degan ma'noni

bildiradi. Protsent so'zi o'rniga % belgisi ishlatiladi. Har qanday miqdorning (sonning) 1% iga uning  $\frac{1}{100}$  bo'lagi (ulushi) va biror miqdorning  $\frac{1}{100}$  ulushiga uning 1% i mos keladi.  $1\% = \frac{1}{100} = 0,01$ .

M i s o l l a r. 1)  $5\% = 5 : 100 = 0,05$ ;  $72\% = 72 : 100 = 0,72$ ;  
 $115\% = 115 : 100 = 1,15$ ;

2)  $1 = 1 \cdot 100\% = (1 : 0,01) = 100\%$ ;  $9 = 9 \cdot 100\% = 900\%$ ;

$4,12 = 4,12 \cdot 100\% = 412\%$ ;  $23\frac{3}{4} = 23,75 \cdot 100\% = 2375\%$ .

Sonning (miqdorning) mingdan bir bo'lagi (ulushi) promilli deb ataladi va ‰ bilan ifodalanadi:

$$1 \text{ ‰} = \frac{1}{1000} = 0,001.$$

Protsentga doir quyidagi uchta masala ko'proq uchraydi:

**1) Berilgan sonning berilgan protsentini topish.**

$a$  berilgan son, uning  $p\%$  ini topamiz. Buning uchun proporsiya tuzamiz:

$$\begin{array}{l} a - 100\% \\ x - p\% \end{array} \Bigg| x = \frac{a \cdot p}{100}$$

Demak, berilgan sonning berilgan protsentini topish uchun sonni shu protsentga mos songa ko'paytirib, ko'paytmani 100 ga bo'lish kerak.

M i s o l: 1200 ning 45% ini toping.

Yechilishi:  $x = \frac{1200 \cdot 45}{100} = 12 \cdot 45 = 540$ .

J a v o b: 540.

**2) Berilgan protsentiga ko'ra sonning o'zini topish.**  $N$  sonining  $p\%$  i  $b$  ga teng.  $N$  ni toping.

$$\begin{array}{l} N - 100\% \\ b - p\% \end{array} \Bigg| N = \frac{b \cdot 100}{p}$$

Sonning berilgan protsentiga ko'ra o'zini topish uchun, protsentga mos sonni 100 ga ko'paytirib, ko'paytmani protsentga bo'lish kerak.

M a s a l a. Paxtadan 35% tola olinadi. 840 kg tola olish uchun qancha paxta kerak bo'ladi?

Yechilishi:

$$\begin{array}{l} x - 100\% \\ 840 - 35\% \end{array} \left| x = \frac{840 \cdot 100}{35} = 24 \cdot 100 = 2400 \text{ kg.} \right.$$

J a v o b: 2400 kg.

3) Ikki sonning protsent nisbatini topish. Buning uchun birinchi sonni ikkinchi songa bo'lish, natijani 100 ga ko'paytirib, so'ngra % belgisini qo'yish kerak.

M a s a l a. Bekzod 350 betlik kitobning 210 betini o'qib bo'ldi. U kitobning necha protsentini o'qigan?

Y e c h i l i s h i:

$$p = \frac{m}{n} \cdot 100\% \text{ ga ko'ra } p = \frac{210}{350} \cdot 100\% = 60\% \text{ ni o'qigan.}$$

J a v o b: 60%.

## 7- §. O'rta qiymatlar

O'rta qiymatlardan eng ko'p ishlatiladiganlari o'rta arifmetik, o'rta geometrik, o'rta vaznli va o'rta garmonik qiymatlardir.

7.1. O'rta arifmetik qiymat. Berilgan miqdorlarning son qiymatlarini qo'shib, yig'indini qo'shiluvchilar soniga bo'lish natijasida o'rta arifmetik qiymat hosil bo'ladi. Berilgan  $a_1, a_2, a_3, \dots, a_n$  sonlarning o'rta arifmetik qiymatini  $A$  deb belgilasak,

$$A = \frac{a_1 + a_2 + a_3 + \dots + a_n}{n},$$

bu yerda  $n$  – qo'shiluvchilar soni.

1-m a s a l a.  $-12; 10; 20$  sonlarining o'rta arifmetik qiymatini toping.

$$\text{Y e c h i l i s h i: } A = \frac{-12 + 10 + 20}{3} = \frac{18}{3} = 6.$$

J a v o b: 6.

2-m a s a l a.  $0,289; 0,32; 0,291; 0,3$  sonlarning o'rta arifmetik qiymatini toping.

$$\text{Y e c h i l i s h i: } A = \frac{0,289 + 0,32 + 0,291 + 0,3}{4} = 0,3.$$

J a v o b: 0,3.

3-m a s a l a.  $a, 1,8$  va  $-5,6$  sonlarining o'rta arifmetigi  $1,2$  ga teng.  $a$  ning qiymatini toping.

$$\text{Yechilishi: } A = \frac{a+1,8-5,6}{3} = 1,2 \Rightarrow a+1,8-5,6 = 3,6 \Rightarrow [a = 7,4.$$

J a v o b: 7,4.

4-m a s a l a. Traktorchi birinchi kuni 5 ga, ikkinchi kuni 5,8 ga, uchinchi kuni esa 6 ga yerni shudgor qildi. U bir kunda o'rtacha qancha maydonni shudgor qilgan?

$$\text{Yechilishi: } \frac{5+5,8+6}{3} = \frac{16,8}{3} = 5,6.$$

J a v o b: 5,6 ga.

5-m a s a l a. Biror miqdor uchta qiymatining o'rta arifmetigi 4 ga, beshtasining o'rta arifmetigi esa 5 ga teng. Shu qiymatlarning yig'indisini toping.

Yechilishi:

$$1) \frac{a_1+a_2+a_3}{3} = 4 \Rightarrow a_1 + a_2 + a_3 = 12.$$

$$2) \frac{b_1+b_2+b_3+b_4+b_5}{5} = 5 \Rightarrow b_1 + b_2 + b_3 + b_4 + b_5 = 25.$$

$$3) a_1 + a_2 + a_3 + b_1 + b_2 + b_3 + b_4 + b_5 = 12 + 25 = 37.$$

J a v o b: 37.

**7.2. O'rta geometrik qiymat.** O'rta geometrik qiymat berilgan miqdorlarning qiymatlarini bir-biriga ko'paytirib, natijasidan ko'paytuvchilar soniga teng darajali ildiz chiqarish yo'li bilan topiladi. Berilgan  $a_1, a_2, a_3, \dots, a_n$  somlarning o'rta geometrik qiymatini  $B$  deb belgilasak,

$$B = \sqrt[n]{a_1 \cdot a_2 \cdot a_3 \cdot \dots \cdot a_n},$$

bunda  $n$  – berilgan miqdorlar soni ( $n$ - darajali ildiz tushunchasi  $V$  bobda berilgan).

Berilgan miqdorlarning qiymatlari bir-biriga teng bo'lgan holdan boshqa hollarning hammasida o'rta geometrik qiymat o'rta arifmetik qiymatdan kichik bo'ladi. Berilgan sonlar teng bo'lganda o'rta geometrik qiymat o'rta arifmetik qiymatga teng bo'ladi, xususan  $n = 2$  da

$$\frac{a+b}{2} \geq \sqrt{ab}.$$



$\sqrt{ab}$  – berilgan  $a$  va  $b$  miqdorlarning o'rta proporsionali ham deb ataladi.

5-misol. 8; 64; 0,027 sonlarining o'rta geometrik qiymatini toping.

Yechilishi:

$$B = \sqrt[3]{8 \cdot 64 \cdot 0,027} = \sqrt[3]{2^3 \cdot 4^3 \cdot (0,3)^3} = 2 \cdot 4 \cdot 0,3 = 2,4.$$

Javob: 2,4.

6-misol.  $x$ ; -5; 25 sonlarining o'rta geometrik qiymati -5 ga teng bo'lsa,  $x$  ni toping.

Yechilishi:

$$\sqrt[3]{x \cdot (-5) \cdot 25} = -5 \Leftrightarrow \left( \sqrt[3]{x \cdot (-5) \cdot 25} \right)^3 = (-5)^3 \Leftrightarrow$$

$$\Leftrightarrow x \cdot (-5) \cdot 25 = -125 \Rightarrow [x = 1.$$

Javob: 1.

### 7.3. O'rta vaznli qiymat. Ushbu masalani qaraylik.

5-masala. Qoramol uchun yem tayyorlashda oziqaning uch xilidan foydalanildi. Birinchi oziqa bir kilogramining narxi 26,25 so'm, ikkinchisniki 30,5 so'm, uchinchisining narxi 40,5 so'mdan. Birinchi oziqadan 48,5 kg, ikkinchisidan 35,5 kg va uchinchi oziqadan 16 kg olinib, bular aralashtirilib omixta yem tayyorlandi. Omixta yemning har bir kilogramiga necha so'mdan sarflangan?

Yechilishi:

- 1) Birinchi oziqaning jami narxi:  $48,5 \cdot 26,25 = 1273,125$  so'm.
- 2) Ikkinchi oziqaning jami narxi:  $35,5 \cdot 30,25 = 1073,875$  so'm.
- 3) Uchinchi oziqaning jami narxi:  $16 \cdot 40,5 = 648$  so'm.
- 4) Omixtaning og'irligi:  $48,5 + 35,5 + 16 = 100$  kg.
- 5) Omixta yemning bir kilogramining narxi:

$$\frac{1273,125 + 1073,875 + 648}{100} = \frac{2995}{100} = 29,95.$$

Javob: 29,95 so'm.

Umuman, bahosi  $a$  so'mlik  $p$  kg,  $b$  so'mlik  $n$  kg va  $c$  so'mlik  $m$  kg mahsulotlar aralashmasining bir kilogramining narxi o'rtacha

$$\frac{a \cdot p + b \cdot n + c \cdot m}{p + n + m}$$

so'm bo'ladi. Bu kabi ifodalar *o'rta vaznli qiymat* deyiladi.

$a, b, c$  sonlarning *o'rta vaznli qiymati* deb

$$C = \frac{a \cdot p + b \cdot n + c \cdot m}{p + n + m}$$

songa aytiladi, bu yerda  $p, m, n$  – musbat sonlar. Agar  $p = m = n$  bo'lsa, *o'rta vaznli qiymat* *o'rta arifmetik qiymat*ga teng bo'ladi.

6-m a s a l a. Harorati  $25^\circ$  bo'lgan 18 l/suvga, harorati  $50^\circ$  bo'lgan 12 l/suv qo'shildi. Idishdagi suvning harorati endi necha gradus?

Yechilishi:

$$C = \left( \frac{18 \cdot 25 + 12 \cdot 50}{18 + 12} \right) = \left( \frac{450 + 600}{30} \right) = \left( \frac{1050}{30} \right) = 35^\circ.$$

Javob:  $35^\circ$ .

**7.4. O'rta garmonik qiymat.** Quyidagi masalani qaraylik.

7-m a s a l a.  $A$  va  $B$  shaharlar orasidagi masofa  $a$  km. Poyezd  $A$  dan  $B$  ga  $v_1$  km/soat,  $B$  dan  $A$  ga esa  $v_2$  km/soat tezlik bilan yuradi. Borish va kelishdagi yo'lni poyezd o'rtacha necha km/soat tezlik bilan o'tgan?

Yechilishi:

1) Poyezd  $A$  shahardan  $B$  shaharga yetib borish uchun

$$t_1 = \frac{a}{v_1} \text{ soat}$$

vaqt sarflagan.

2)  $B$  shahardan  $A$  shaharga qaytishda sarflangan vaqti:

$$t_2 = \frac{a}{v_2} \text{ soat.}$$

3) Hammasi bo'lib borib-kelish uchun sarflangan vaqt:

$$t_1 + t_2 = \frac{a}{v_1} + \frac{a}{v_2} = \frac{av_1 + av_2}{v_1 v_2}.$$

4) Bosib o'tilgan yo'lning hammasi  $a$  km ga teng bo'lganligi sababli poyezdning o'rtacha tezligi

$$\frac{2a}{\frac{av_1 + av_2}{v_1 v_2}} = 2a \cdot \frac{v_1 v_2}{a(v_1 + v_2)} = \frac{2v_1 v_2}{v_1 + v_2} \text{ km/soat.}$$

J a v o b:  $\frac{2v_1v_2}{v_1+v_2}$  soat.

Umuman,  $a$  va  $b$  sonlar berilsa,

$$D = \frac{2ab}{a+b}$$

ifoda  $a$  va  $b$  sonlarning *o'rtta garmonik qiymati* deyiladi.

8-m a s a l a. Poyezd  $A$  shahardan  $B$  ga 55 km/soat tezlik bilan yurdi.  $B$  dan  $A$  ga qaytishda u soatiga 45 km tezlik bilan yurdi. Poyezd borish va kelishdagi yo'lni o'rtacha necha km/soat bilan o'tgan?

Y e c h i l i s h i:

$$v = \frac{2 \cdot 55 \cdot 45}{55 + 45} = \frac{4950}{100} = 49,5 \text{ km/soat.}$$

J a v o b: 49,5 km/soat.

## 8-§. Haqiqiy sonlar to'plami

**8.1. Ratsional va irratsional sonlar.** T a ' r i f. *Faqat ishorasi bilan farqlanadigan ikki son qarama-qarshi sonlar deyiladi.*

T a ' r i f. *Natural sonlar, ularga qarama-qarshi sonlar va 0 soni birgalikda butun sonlar deyiladi.*

...,  $-n$ ,  $-(n-1)$ , ...,  $-3$ ,  $-2$ ,  $-1$ ,  $0$ ,  $1$ ,  $2$ ,  $3$ , ...,  $n-1$ ,  $n$  ... sonlar butun sonlardir. Butun sonlar to'plami  $Z$  harfi bilan belgilanadi.

T a ' r i f. *Barcha butun sonlar, manfiy va musbat kasr sonlar birgalikda ratsional sonlar to'plami deyiladi.*

Ratsional sonlar to'plami  $Q$  harfi bilan belgilanadi. Har qanday ratsional sonni  $\frac{p}{q}$  ko'rinishida belgilanadi, bunda  $p \in Z$ ,  $q \in N$ .

$\frac{5}{7}$ ;  $-\frac{13}{17}$ ;  $0,21$ ;  $27\frac{2}{3}$ ;  $5,1(6)$  kabi sonlar ratsional sonlardir.

Har qanday ratsional sonni o'nli kasr ko'rinishida yozish mumkin, bunda yo chekli, yo cheksiz davriy o'nli kasr hosil bo'ladi. Masalan,

$$\frac{1}{8} = 0,125; 2\frac{3}{4} = 2,75; \frac{11}{3} = 3\frac{2}{3} = 3,666\dots$$

T a ' r i f. *Davriy bo'lmagan cheksiz o'nli kasrlar irratsional sonlar deyiladi.*

$\sqrt{2}, \sqrt{3}, \sqrt{5}, \sqrt{6}, \dots, \pi, e$  sonlari irratsional sonlarga misol bo'ladi ( $\pi \approx 3,14159265 \dots, e \approx 2,71826763 \dots$ )

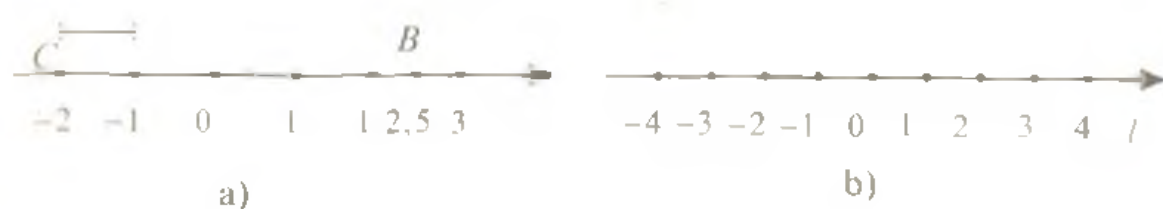

1-rasm

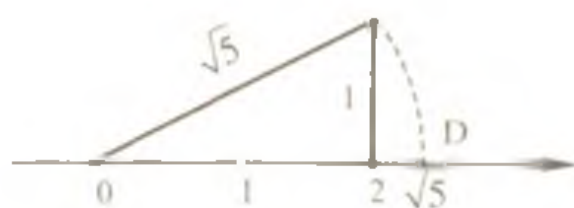

2-rasm

**8.2. Son o'qi.** Ta'rif. *Sanoq boshi, o'lchov birligi va yo'nalishga ega bo'lgan to'g'ri chiziq son o'qi deyiladi.*

Son o'qidagi har bir nuqtaga aniq bir son mos keladi va aksincha, har bir songa son o'qida aniq bir nuqta mos keladi.

Ta'rif. *Ratsional va irratsional sonlar to'plami birgalikda haqiqiy sonlar to'plami deyiladi.*

Haqiqiy sonlar to'plami  $R$  harfi bilan belgilanadi.

Son o'qi nuqtalari bilan haqiqiy sonlar to'plami o'zaro bir qiymatlidir. Son o'qida barcha haqiqiy sonlar ma'lum tartibda joylashtirilgan bo'lib, o'ngdagi har bir son o'zidan chap tarafda turgan sonlardan katta, o'ng tarafda turganlardan kichik bo'lib, son o'qining musbat yo'nalishi sonlarning o'sib borish yo'nalishiga mos keladi (1-rasm).

Nuqtaning son o'qidagi o'rnini ifodasi uning *koordinatasi* deb ataladi. 1-rasmda  $C$  nuqtaning koordinatasi  $-2$ ,  $B$  nuqtaning koordinatasi  $2.5$ . Har bir nuqta o'z koordinatasi bilan  $C(-2), B(2.5)$  tarzda yoziladi.

**1-masala.** Koordinatali to'g'ri chiziqda  $D(\sqrt{5})$  nuqtani ko'rsating.

**Yechilishi:**  $\sqrt{5}$  ni  $\sqrt{2^2 + 1^2}$  tarzida ifodalash mumkin. Bundan  $\sqrt{5}$  ning katetlari  $2$  va  $1$  bo'lgan to'g'ri burchakli



3-rasm

uchburchakning gipotenuzasining uzunligi ekanligi ayon bo'ladi. Uni sanoq boshidan qo'yib,  $D(\sqrt{5})$  nuqta topiladi (2-rasm).

**8.3. Sonning moduli (absolut qiymati).** Ta'rif.  $a$  sonning absolut qiymati (moduli) deb, agar  $a \geq 0$  bo'lsa, shu sonning o'ziga, agar  $a < 0$  bo'lsa, u holda  $a$  ga qarama-qarshi songa aytiladi.

$a$  sonning moduli  $|a|$  kabi belgilanadi va ta'rifga ko'ra

$$|a| = \begin{cases} a, & \text{agar } a \geq 0 \text{ bo'lsa,} \\ -a, & \text{agar } a < 0 \text{ bo'lsa.} \end{cases}$$

Son modulining geometrik talqini sonlar o'qida  $a$  sonni tasvirlovchi nuqtadan sanoq boshigacha bo'lgan masofa uzunligidir. Agar  $a \neq 0$  bo'lsa, sonlar o'qida sanoq boshidan teng uzoqlikda joylashgan moduli teng bo'lgan ikkita  $a$  va  $-a$  nuqtalar mavjud (3-rasm).

Koordinatali to'g'ri chiziqda (son o'qida) sanoq boshidan 5 birlik masofadagi  $A$  va  $B$  nuqtalarning koordinatalari  $-5$  va  $5$  dir.  $OA$  va  $OB$  masofalar o'zaro teng bo'lib, odatda  $|OA| = |OB|$  tarzida yoziladi.

Sonning moduli quyidagi xossalarga ega:

$$1. |a + b| \leq |a| + |b|. \quad 2. |a - b| \geq |a| - |b|.$$

$$3. |a \cdot b| = |a| \cdot |b|. \quad 4. = \frac{a}{b}.$$

Misollar:

$$1) |8| = 8; \quad 2) |-3,2| = -(-3,2) = 3,2.$$

$$3) a = 2,5 \Rightarrow a = \pm 2,5.$$

$$4) \frac{|5-3|4-6|+2|3-5||}{|3-2|5-7|} \text{ ni hisoblang.}$$

Yechilishi:

$$\frac{|5-3|4-6|+2|3-5||}{|3-2|5-7|} = \frac{|5-3|-2|+2|-2||}{|3-2|-2|} = \frac{|5-6+4|}{|3-4|} = \frac{3}{1} = 3.$$

Javob: 3.

5) Agar  $x > y > z$  bo'lsa,  $|x - y| - |z - y| - |z - x|$  ni soddalashtiring.

Yechilishi: Masala shartiga ko'ra

$$x - y > 0; z - y < 0; z - x < 0.$$

Shu sababli, modul ta'rifiga asosan:

$$\begin{aligned}x - y - z - y - z - x &= x - y - (-(z - y)) - (-(z - x)) = \\ &= x - y + z - y + z - x = 2z - 2y.\end{aligned}$$

Javob:  $2z - 2y$ .

### Mustaqil ishlash uchun test topshiriqlari

1. 15 sonining  $\frac{3}{5}$  bo'lagi qancha bo'ladi?

A) 7;      B) 10;      C) 11;      D) 9;      E) 8.

2. Xaridor 255 so'm pulining  $\frac{1}{3}$  qismini birinchi do'konda,  $\frac{1}{4}$  qismini ikkinchi do'konda sarf qildi. Xaridorda sarflaganidan necha so'm kam pul qoldi?

A)  $41\frac{1}{2}$ ;      B)  $42\frac{1}{2}$ ;      C)  $43\frac{2}{3}$ ;      D)  $40\frac{1}{2}$ ;      E)  $42\frac{3}{4}$ .

3. To'g'ri tenglikni ko'rsating:

1)  $5\frac{5}{13} = \frac{70}{13}$ ; 2)  $3\frac{7}{13} = 3 + \frac{1}{13}$ ;      3)  $10\frac{1}{3} = \frac{33}{3}$ .

A) 1; 2;      B) 2; 3;      C) 1;      D) 3;      E) 1; 3.

4. Hisoblang:  $5\frac{3}{4} - 2\frac{1}{3} + 3$ .

A)  $2\frac{7}{12}$ ;      B)  $3\frac{5}{12}$ ;      C)  $3\frac{1}{12}$ ;      D)  $6\frac{5}{12}$ ;      E)  $3\frac{11}{12}$ .

5. Kasrlarni kamayish tartibida yozing: 1)  $\frac{3}{4}$ ; 2)  $\frac{4}{5}$ ; 3)  $\frac{2}{3}$ .

A) 1, 2, 3;      B) 2, 3, 1;      C) 3, 2, 1;      D) 3, 1, 2;      E) 2, 1, 3.

6. Avtomobil soatiga  $42\frac{6}{7}$  km tezlik bilan harakat qilsa, u 1 minutda necha km yo'l bosadi?

A)  $1\frac{5}{7}$ ;    B)  $\frac{5}{7}$ ;    C)  $\frac{2}{7}$ ;    D)  $2\frac{1}{7}$ ;    E)  $1\frac{3}{7}$ .

7.  $\frac{5}{8}$  soni  $\frac{5}{24}$  sonidan necha marta katta?

A) 3;    B) 2;    C) 4;    D) 5;    E) 6.

8. Ayirmani toping:  $\frac{4}{11} - \frac{4}{13}$ .

A)  $\frac{8}{11}$ ;    B)  $\frac{8}{13}$ ;    C)  $\frac{8}{143}$ ;    D)  $\frac{7}{143}$ ;    E)  $\frac{9}{143}$ .

9. Bog'chada 210 ta bola bor. Ularning  $\frac{4}{7}$  qismi qiz bolalar.

Bog'chada qancha o'g'il bola bor?

A) 100;    B) 80;    C) 95;    D) 96;    E) 90.

10. Amallarni bajaring:  $\frac{8}{11} \cdot \frac{1}{21} : 1\frac{5}{7}$ .

A)  $\frac{1}{99}$ ;    B)  $\frac{3}{99}$ ;    C)  $\frac{5}{99}$ ;    D)  $\frac{2}{99}$ ;    E)  $\frac{4}{99}$ .

11.  $6 - \frac{7}{12}$  ayirmaga teskari sonni toping:

A)  $\frac{9}{65}$ ;    B)  $\frac{11}{65}$ ;    C)  $\frac{7}{65}$ ;    D)  $\frac{8}{65}$ ;    E)  $\frac{12}{65}$ .

12. Agar  $a = 5\frac{3}{4}$ ,  $b = 2\frac{1}{4}$  bo'lsa,  $(a + b)^2 - 4ab$  ifodaning qiymatini toping.

A)  $12\frac{3}{4}$     B)  $12\frac{1}{4}$     C)  $13\frac{1}{4}$ ;    D)  $\frac{3}{4}$ ;    E)  $\frac{1}{4}$ .

13. Quyidagi kasrlardan qaysi birining qiymati  $2\frac{1}{4}$  ga teng?

A)  $\frac{10}{4}$ ;    B)  $\frac{11}{4}$ ;    C)  $\frac{17}{8}$ ;    D)  $\frac{9}{4}$ ;    E)  $\frac{20}{8}$ .

14. Quyidagi kasrlardan qaysi biri noto'g'ri kasrdan iborat?

1)  $\frac{11}{20}$ ; 2)  $1\frac{1}{2}$ ; 3)  $\frac{7}{8}$ ; 4)  $\frac{4}{3}$ ; 5)  $1\frac{1}{12}$ .

A) 1, 3, 5;    B) 2, 4, 5;    C) 2, 3, 4;    D) 1, 3, 4;    E) 1, 2, 3.

15.  $-\frac{1}{3} \cdot \left(-\frac{2}{7}\right) : \frac{5}{42}$  ni hisoblang.

- A)  $\frac{3}{5}$ ;      B)  $\frac{5}{4}$ ;      C)  $\frac{4}{5}$ ;      D)  $\frac{1}{5}$ ;      E)  $1\frac{1}{5}$ .

16. Hisoblang:  $1,75 - \left(-1\frac{2}{7}\right) \cdot 6,5 \cdot \frac{7}{9}$ .

- A)  $-4,75$ ;    B)  $2,15$ ;    C)  $8,25$ ;    D)  $4,75$ ;    E)  $7,55$ .

17.  $0,015 \cdot 0,016$  ko'paytma quyidagi sonlardan qaysi biriga teng emas?

- A)  $2,4 \cdot 10^{-4}$ ; B)  $0,24 \cdot 10^{-3}$ ; C)  $24 \cdot 10^{-5}$ ; D)  $240 \cdot 10^{-6}$ ; E)  $2,4 \cdot 10^{-5}$ .

18.  $a = 0,22(23)$ ,  $b = 0,2(23)$ ,  $c = 0,222(3)$  sonlarni kamayish tartibida yozing.

- A)  $c > a > b$ ; B)  $a > b > c$ ; C)  $b > c > a$ ; D)  $c > b > a$ ; E)  $b > a > c$ .

19.  $27 \cdot 10^{-5} + 3,205 \cdot 10^{-3}$  yig'indi quyidagi sonlarning qaysi biriga teng?

- A)  $5,906 \cdot 10^{-3}$ ; B)  $5,906 \cdot 10^{-4}$ ; C)  $3,475 \cdot 10^{-3}$ ;  
D)  $3,0215 \cdot 10^{-4}$ ; E)  $5,906 \cdot 10^{-7}$ .

20.  $\frac{6,8 \cdot 0,04 \cdot 1,65}{3,3 \cdot 5,1 \cdot 0,16}$  ning qiymatini toping.

- A) 6;      B)  $\frac{1}{2}$ ;      C)  $\frac{2}{3}$ ;      D)  $\frac{1}{6}$ ;      E)  $\frac{5}{12}$ .

21.  $x$ ,  $-2,1$  va  $3,3$  sonlarining o'rta arifmetigi  $0,2$  ga teng.  $x$  ni toping.

- A)  $0,6$ ;    B)  $-0,6$ ;    C)  $0,8$ ;    D)  $2$ ;      E)  $-0,8$ .

22.  $a = 0,7(2)$ ,  $b = \frac{11}{15}$  va  $c = 1 - 0,2(8)$ .  $a$ ,  $b$ ,  $c$  sonlar uchun quyidagi munosabatlardan qaysi biri o'rinli?

- A)  $a < c < b$ ; B)  $a < b < c$ ; C)  $b < c < a$ ; D)  $c < a < b$ ; E)  $b < a < c$ .

23. Ushbu oddiy kasrlarning qaysi biri chekli o'nli kasrga aylanmaydi?

- 1)  $3\frac{7}{15}$ ;    2)  $1\frac{3}{8}$ ;    3)  $\frac{317}{125}$ ;    4)  $\frac{25}{27}$ ;

- A) 1, 3;    B) 3, 4;    C) 1;      D) 4;      E) 1, 4.

24. Hisoblang:  $13,17 \cdot 8,31 + 58,76 \cdot 8,31 - 31,93 \cdot 8,31$ .

- A)  $415,3$ ;    B)  $315,5$ ;    C)  $416$ ;    D)  $415,2$ ;    E)  $332,4$ .

25.  $5\frac{8}{15}$  oddiy kasr quyidagi davriy o'nli kasrlarning qaysi biriga teng.

- A)  $5,5(3)$ ;    B)  $5,(53)$ ;    C)  $5,55(3)$ ;    D)  $5,(03)$ ;    E)  $5,0(53)$ .



26. Ifodaning qiymatini toping:

$$12,5 + \left(17,5 - 8,25 \cdot \frac{10}{11}\right) \cdot \left(11\frac{2}{3} : 2\frac{2}{9} + 3,5\right) - 12,6 : 2\frac{1}{2}.$$

- A) 94,96; B) 9,496; C) 949,6; D) 9496; E) -5,04.

27.  $\frac{\left(1\frac{1}{12} + 2\frac{5}{32} + \frac{1}{24}\right) \cdot 9,6 + 2,13}{0,4}$  ni hisoblang.

- A)  $\frac{3}{4}$ ; B)  $8\frac{3}{4}$ ; C)  $83\frac{3}{4}$ ; D)  $84\frac{3}{40}$ ; E)  $84\frac{3}{4}$ ;

28.  $\frac{0,125 : 0,25 + 1\frac{9}{16} : 2,5}{(10 - 22 : 2,3) \cdot 0,46 + 1,6} + \left(\frac{17}{20} + 1,9\right) \cdot 0,5$  ning qiymatini hisoblang.

- A)  $\frac{1}{2}$ ; B) 2; C)  $\frac{2}{3}$ ; D)  $\frac{1}{4}$ ; E) 2,25.

29.  $\frac{0,8333\dots - 0,4(6)}{1\frac{5}{6}} \cdot \frac{1,125 + 1,75 - 0,41(6)}{0,59}$  ni hisoblang.

- A)  $\frac{6}{5}$ ; B) -1,2; C)  $\frac{5}{6}$ ; D)  $\frac{2}{3}$ ; E)  $\frac{1}{6}$ .

30\*. Sonli ifodaning qiymatini toping.

$$\frac{((7 - 6,35) : 6,5 + 9,8999\dots) \cdot (12,8)^{-1}}{(1,2 : 36 + (1\frac{1}{5} : 0,25 - 1,8(3))) \cdot 1,25} : 0,125.$$

- A)  $\frac{3}{5}$ ; B)  $\frac{2}{5}$ ; C)  $\frac{1}{5}$ ; D)  $\frac{5}{7}$ ; E)  $\frac{5}{3}$ .

31. Nisbatning noma'lum hadini toping:  $x : 4\frac{1}{5} = 2\frac{1}{7}$ .

- A)  $1\frac{2}{3}$ ; B) 9; C)  $2\frac{3}{5}$ ; D) 8; E) 8,5.

32. Quyidagi nisbatlarning qaysi birlari o'zaro teng: 1)  $3 : 7$ ; 2)

$13\frac{1}{2} : 31\frac{1}{2}$ ; 3)  $15 : 21$ ; 4)  $0,24 : 0,48$ .

- A) 1, 3; B) 2, 4; C) 2, 3; D) 1, 2; E) 1, 4.

33. 180 sonini 3, 5, 7 sonlariga proporsional bo'laklarga bo'ling.

- A) 36, 60, 84; B) 32, 62, 84; C) 24, 32, 48; D) 34, 56, 92;  
E) 38, 52, 90.

34. 434 sonini 15 va 16 sonlariga teskari proporsional bo'laklarga bo'ling.

- A) 224; 210; B) 214; 220; C) 217; 217; D) 218; 216; E) 200; 234.

35.  $2\frac{4}{5} : x = 1\frac{2}{3} : 2\frac{6}{7}$  proporsiyaning noma'lum hadini toping.

- A)  $\frac{1}{2}$ ; B)  $\frac{2}{3}$ ; C)  $4\frac{4}{5}$ ; D)  $\frac{3}{5}$ ; E)  $2\frac{1}{5}$ .

36. Go'sht qaynatilganda o'z massasining 40% ini yo'qotadi. 12 kg qaynatilgan go'sht hosil qilish uchun qozonga qancha kilogramm go'sht solish kerak?

- A) 18,4; B) 16; C) 18,2; D) 18; E) 20.

37. Sonning 12% i 24 ga teng, shu sonning 75% ini toping.

- A) 110; B) 125; C) 150; D) 120; E) 135.

38. Uzunligi 50,6 m bo'lgan arqon shunday ikki bo'lakka bo'linadiki, ulardan biri ikkinchisidan 20% ga uzun. Arqon bo'laklari uzunligini toping.

- A) 30,36; 20,24; B) 35,36; 15,24; C) 30,22; 20,38  
D) 28,30; 22,30; E) 23; 27,6.

39. 12,64 ning 3,16 ga protsent nisbatini toping.

- A) 350; B) 405; C) 390; D) 375; E) 400.

40. Uch xonali son bilan shu sonni teskari tartibda yozishdan hosil bo'lgan sonning ayirmasi qoldiqsiz bo'linadigan sonni ko'rsating.

- A) 35; B) 43; C) 65; D) 89; E) 99.

41.  $|x - 2|$  ni modul belgisisiz yozing.

- A)  $x - 2$ ; B)  $x + 2$ ; C)  $x - 2$ , agar  $x \geq 2$  bo'lsa;  $-x + 2$ , agar  $x < 2$  bo'lsa; D)  $x - 2$ , agar  $x \geq 0$  bo'lsa;  $-x + 2$ , agar  $x < 0$  bo'lsa;  
E)  $x - 2$ , agar  $x \leq 2$  bo'lsa;  $-x - 2$ , agar  $x > 2$  bo'lsa.

42.  $|-7| + 4 - |-16|$  ni hisoblang.

- A) 27; B) 5; C) 13; D) 19; E) 11.

43.  $|x + 2| - x$  ifodani modul belgisisiz yozing.

- A)  $2x + 2$ ; B) 2, agar  $x > -2$  bo'lsa;  $2(x + 1)$ , agar  $x < -2$  bo'lsa;  
C) 2, agar  $x \leq -2$  bo'lsa;  $-2x - 2$ , agar  $x < -2$  bo'lsa;  
D)  $-2x - 2$ ; E)  $2x - 2$ .

44.  $x$  ning  $-x = |x|$  tenglik o'rinli bo'ladigan qiymatlarini ko'rsating.

- A)  $x > 0$ ; B)  $x \geq 0$ ; C)  $x < 0$ ; D)  $x \leq 0$ ; E)  $(-\infty; +\infty)$ .

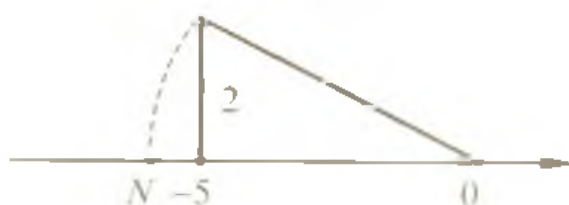

4-rasm

45. 4-rasmda  $N$  nuqtaning koordinatasini aniqlash tasvirlangan.  $N$  nuqta koordinatasini ko'rsating.

- A)  $-6$ ; B)  $-5,5$ ; C)  $-\sqrt{26}$ ; D)  $-\sqrt{29}$ ; E)  $-\sqrt{28}$ .

46. Son o'qidagi  $M$  (2) nuqta 5 birlik chapga,  $R$  ( $-5$ ) nuqta esa 4 birlik o'ngga siljitildi.  $MR$  kesmaning siljitishdan keyingi holati o'rtasining koordinatasini toping.

- A)  $-3$ ; B)  $-2$ ; C)  $-4$ ; D)  $-1$ ; E)  $0$ .

47. Son o'qida  $A$  ( $-5$ ) nuqta berilgan. Shu nuqtadan 3 birlik masofada yotuvchi nuqtalarning koordinatalarini toping.

- A)  $-6; -2$ ; B)  $-7; 0$ ; C)  $-8; -2$ ; D)  $-8; -3$ ; E)  $-7; -2$ .

48. Son o'qida  $A$  ( $-5$ ) va  $B$  ( $7$ ) nuqtalar berilgan.  $AB$  kesma o'rtasining koordinatasini toping.

- A)  $-2$ ; B)  $3$ ; C)  $2$ ; D)  $1$ ; E)  $0$ .

49.  $M$  nuqta  $OA$  kesmaning o'rtasi bo'lib,  $O$  nuqta sanoq boshi,  $A$  ( $-5,2$ ) bo'lsa,  $M$  nuqtaning koordinatasini toping.

- A)  $-3,1$ ; B)  $-2,6$ ; C)  $-2,8$ ; D)  $-2,1$ ; E)  $-2,7$ .

50. Koordinatalar to'g'ri chizig'ida  $A$  ( $-4$ ),  $B$  ( $2$ ),  $C$  ( $-1$ ),  $D$  ( $5$ ) nuqtalar belgilangan.  $AB$  va  $CD$  kesmalar o'rtalari orasidagi masofani toping.

- A)  $3$ ; B)  $2$ ; C)  $4$ ; D)  $5$ ; E)  $2,5$ .

51.  $A$  ( $-3$ ) nuqtaning koordinatasi ( $-6$ ) ga teng bo'lishi uchun sanoq boshini qanday koordinatali nuqtaga siljitish kerak?

- A)  $-3$ ; B)  $-2$ ; C)  $3$ ; D)  $4$ ; E)  $-6$ .

52. Uchta sonning o'rta arifmetigi  $5,63$  ga teng. Ikkinchi son birinchi sondan  $1,24$  ga kam, uchinchi son esa ikkinchisidan  $0,79$  ga kam. Shu sonlarning kattasi nechga teng?

- A)  $6,72$ ; B)  $5,48$ ; C)  $4,69$ ; D)  $16,89$ ; E)  $15$ .

53. Harorati  $36^\circ$  bo'lgan  $6$  l suvga harorati  $15^\circ$  bo'lgan  $8$  l suv qo'shilsa, idishdagi suvning harorati necha gradus bo'ladi?

A)  $51^\circ$ ; B)  $21^\circ$ ; C)  $24^\circ$ ; D)  $30^\circ$ ; E)  $28^\circ$ .

54. Futbol komandasidagi 11 ta o'yinchining o'rtacha yoshi 21 ga teng. O'yin davomida bir futbolchi jarohatlanib, maydonni tark etdi. Shunda qolgan o'yinchilarning o'rtacha yoshi 20,8 ga teng bo'ldi. Maydondan chiqib ketgan o'yinchining yoshini toping.

A) 22; B) 23; C) 19; D) 18; E) 24.

55. Kvadrat tomoni 30% ga orttirildi. Uning yuzi necha foizga ortadi?

A) 30; B) 130; C) 70; D) 60; E) 69.

56. Yog'liqligi 8% va 5% bo'lgan sutni aralashtirib, yog'liqligi 6% bo'lgan 60 litr sut tayyorlash uchun har bir nav sudan qanchadan olish kerak?

A) 30 l va 30 l; B) 15 l va 45 l; C) 20 l va 40 l;  
D) 25 l va 35 l; E) 28 l va 32 l.

57. Ikki sonning o'rta arifmetigi 10 ga, o'rta geometrigi esa 6 ga teng. Shu sonlarni toping.

A) 2 va 8; B) 2 va 18; C) 5 va 15; D) 6 va 14; E) 8 va 12.

58. Uchta sonning o'rta arifmetigi 32.5 ga teng. Birinchi son ikkinchisidan 50% ortiq, ikkinchisi uchinchisining 64% ini tashkil etadi. Shu sonlarning kichigi nechaga teng?

A) 36; B) 37,5; C) 18; D) 24; E) 20.

59. Tarkibida 72% temir bo'lgan 20 t va 40% temir bo'lgan 30 t ma'danlar aralashtirib yuborildi. Hosil bo'lgan aralashmadagi temirning protsent miqdorini aniqlang.

A) 50; B) 56; C) 52,8; D) 45,5; E) 50,5.

60\*. Bir idishda 40% li, ikkinchi idishda 35% li eritma bor. Ularni aralashtirib, 37% li 1 l eritma olish uchun har bir eritmadan necha litrdan olish kerak?

A) 0,3 va 0,7; B) 0,2 va 0,8; C) 0,1 va 0,9; D) 0,55 va 0,45;  
E) 0,4 va 0,6.

**BIRHADLAR VA KO'PHADLAR**

**1-§. Natural va butun ko'rsatkichli daraja**

**1.1. Natural ko'rsatkichli daraja.**  $a$  ixtiyoriy haqiqiy son,  $n$  esa 2 ga teng yoki undan katta natural son bo'lsin. Har biri  $a$  ga teng bo'lgan  $n$  ta sonning ko'paytmasi

$$a \cdot a \cdot a \cdot \dots \cdot a = a^n$$

$a$  sonning  $n$ -darajasi deyiladi. Bunda  $a$  son asos,  $n$  esa daraja ko'rsatkichi deb ataladi.

**1.2. Natural ko'rsatkichli darajaning xossalari.**

1. Manfiy sonning juft ko'rsatkichli darajasi musbat, toq ko'rsatkichli darajasi manfiydir.

Misollar:  $(-5)^5 = -3125$ ,  $(-4)^4 = 256$ .

$$2. (a \cdot b)^n = a^n \cdot b^n. \qquad 5. \frac{a^m}{a^n} = a^{m-n}.$$

$$3. \left(\frac{a}{b}\right)^n = \frac{a^n}{b^n} \quad (b \neq 0). \qquad 6. (a^m)^n = a^{m \cdot n}.$$

$$4. a^m \cdot a^n = a^{m+n}.$$

**1.3. Nol ko'rsatkichli daraja. Butun manfiy ko'rsatkichli daraja.**

Ta'rifga ko'ra, agar  $a \neq 0$  bo'lsa,  $a^0 = 1$ . Masalan,  $(2,7)^0 = 1$ ;  $(-8)^0 = 1$ .

0 sonining nol inchi darajasi ma'noga ega emas.

Agar  $a \neq 0$  va  $n$  natural son bo'lsa, u holda

$$a^{-n} = \frac{1}{a^n}$$

bo'ladi.

Ushbu tenglik o'rinlidir:

$$\left(\frac{a}{b}\right)^{-n} = \left(\frac{b}{a}\right)^n.$$

Natural ko'rsatkichli darajaning 1.2-bandda keltirilgan hamma xossalari istalgan butun ko'rsatkichli darajalar uchun ham to'g'ridir, bunda faqat  $a$  va  $b$  sonlar nolga teng bo'lmasligi kerak.

Misollar. 1)  $b^6 \cdot b^8 \cdot b^0$  ko'paytmani daraja ko'rsatkichi shaklida yozing.

Yechilishi.  $b^6 \cdot b^8 \cdot b^0 = b^{6+8+0} = b^{14}$ .

2) 243 sonini asosi 3 ga teng daraja ko'rsatkichi ko'rinishida yozing.

Yechilishi.  $243 = 3 \cdot 81 = 3 \cdot 3 \cdot 27 = 3 \cdot 3 \cdot 3 \cdot 9 = 3 \cdot 3 \cdot 3 \cdot 3 \cdot 3 = 3^5$ .

3)  $a^{6n+4} : a^5$ . Bo'linmani daraja ko'rsatkichi ko'rinishida yozing.

Yechilishi.  $a^{6n+4} : a^5 = a^{6n+4-5} = a^{3n-1}$ .

4)  $\frac{2 \cdot 5^{22} - 9 \cdot 5^{21}}{25^{10}}$  ifodaning qiymatini hisoblang.

Yechilishi.  $\frac{2 \cdot 5^{22} - 9 \cdot 5^{21}}{25^{10}} = \frac{2 \cdot 5 \cdot 5^{21} - 9 \cdot 5^{21}}{(5^2)^{10}} = \frac{5^{21}(2 \cdot 5 - 9)}{5^{20}} =$

$= 5^{21-20} \cdot (10 - 9) = 5 \cdot 1 = 5$ .

5)  $\frac{14^{10} \cdot 13^6 \cdot 8^4}{2^8 \cdot 7^9 \cdot 26^5}$  ifodaning qiymatini hisoblang.

Yechilishi.  $\frac{14^{10} \cdot 13^6 \cdot 8^4}{2^8 \cdot 7^9 \cdot 26^5} = \frac{(7 \cdot 2)^{10} \cdot 13^6 \cdot (2^3)^4}{2^8 \cdot 7^9 \cdot (2 \cdot 13)^5} = \frac{7^{10} \cdot 2^{10} \cdot 13^6 \cdot 2^{12}}{2^8 \cdot 7^9 \cdot 2^5 \cdot 13^5} =$

$= \frac{2^{10+12} \cdot 7^{10} \cdot 13^6}{2^{8+5} \cdot 7^9 \cdot 13^5} = 2^{22-13} \cdot 7^{10-9} \cdot 13^{6-5} = 2^9 \cdot 7 \cdot 13 = 46592$ .

6) Hisoblang:  $3^{-3} - \left(\frac{3}{4}\right)^{-4} \cdot \left(-\frac{1}{2}\right)^6$   
 $10^{-1} + \left(-\frac{1}{5}\right)^0$

$$\text{Yechilishi. } \frac{3^{-3} - \left(\frac{3}{4}\right)^{-4} \cdot \left(-\frac{1}{2}\right)^6}{10^{-1} + \left(-\frac{1}{5}\right)^0} = \frac{\frac{1}{27} - \frac{4^4}{3^4} \cdot \frac{1}{2^6}}{\frac{1}{10} + 1} = \frac{\frac{1}{27} - \frac{2^8}{3^4} \cdot \frac{1}{2^6}}{\frac{11}{10}}$$

$$\left(\frac{1}{27} - \frac{4}{81}\right) \cdot \frac{10}{11} = -\frac{1}{81} \cdot \frac{10}{11} = -\frac{10}{891}.$$

## 2-§. Birhadlar va ko'phadlar

**2.1. Birhadlar. Ta'rif.** Faqat ko'paytirish va darajaga ko'tarish amallarini o'z ichiga olgan ifoda birhad deyiladi.

Masalan,  $2a$ ;  $4a^3$ ;  $\frac{1}{3} a^2b^3c$ .

Xususan birhad bitta son yoki bitta harfdan iborat bo'lishi ham mumkin. Masalan,  $-2$ ;  $2,7$ ;  $-a^2$ ;  $b$ . Birhad oldida sonli ko'paytuvchi yozilgan bo'lib, har bir o'zgaruvchi bitta daraja shaklida ifoda qilingan bo'lsa, birhadning bunday shakli *birhadning standart shakli* deyiladi.

Masalan,  $5a^2$ ;  $-0,5ab^3$ ;  $\frac{5}{6} p^4q^2$ .

Standart shakldagi birhadning sonli ko'paytuvchisi *birhadning koeffitsiyenti* deyiladi.

$3x^2y$  ning koeffitsiyenti 3 ga,  $a^2$  ning koeffitsiyenti 1 ga,  $-y^5$  ning koeffitsiyenti  $-1$  ga teng.

Birhadlarni ko'paytirish uchun ularning koeffitsiyentlarini o'zaro ko'paytirish, bir xil harflarning daraja ko'rsatkichlarini qo'shish va faqat bitta ko'paytuvchida bo'lgan harflarni o'z ko'rsatkichlari bilan ko'paytmaga yozish kerak.

Misolalar. 1)  $0,5ab^3c^3 \cdot (-6a^2bc^4) = -3a^3b^3c^7$ ;

$$2) 3x^2y \cdot 2xy^3 \cdot \frac{1}{5} x^3z = \frac{6}{5} x^6y^4z.$$

Ikki yoki bir nechta aynan bir xil bir hadlar ko'paytmasini ko'rsatkichli darajaning xossasidan foydalanib hisoblash qulay:

$$(5a^3b^2c^3)^4 = 5^4 \cdot (a^3)^4 \cdot (b^2)^4 \cdot (c^3)^4 = 625a^{12}b^8c^{12}.$$

**2.2. Ko'phadlar.** Ta'rif. *Bir nechta birhadlarning algebraik yig'indisi ko'phad deyiladi.* Masalan,  $\frac{1}{3}a^2b + 4a^6 - 2b$  ko'phaddir.

Ko'phadning faqat koeffitsiyenti bilan farq qiladigan hadlari *o'xshash hadlar* deyiladi. Ko'phadda o'xshash hadlar yig'indisini shu yig'indiga teng bo'lgan birhadga almashtirish *o'xshash hadlarni ixchamlash* deyiladi.

Misol.  $4x^2y - 5c - 2x^2y + 8x^2y + 8c = (4 - 2 + 8)x^2y + (8 - 5)c = 10x^2y + 3c.$

Ko'phadning har bir hadi standart shaklda yozilgan va ular orasida o'xshash hadlar bo'lmasa, ko'phadning bunday shakli *standart shakl* deyiladi.

Har qanday ko'phadni standart shaklda yozish mumkin.

Misol.  $3xy^2 + 4x^3 - 5x^2y - 3x^3 + 4x^2y - 4xy^2 = (3 - 4)xy^2 + (4 - 3)x^3 + (-5 + 4)x^2y = -xy^2 + x^3 - x^2y.$

**2.3. Ko'phadlar va birhadlar ustida amallar.** Ko'phadlarning yig'indisini topish uchun ularning har bir hadini o'z ishoralari bilan yozib chiqish va hosil bo'lgan yig'indida o'xshash hadlari bo'lsa, ularni ixchamlash kerak.

Misol.  $(7x + 5y^2 + 3) + (3y^2 - 4x - xy) = 7x + 5y^2 + 3 + 3y^2 - 4x - xy = (7 - 4)x + (5 + 3)y^2 - xy + 3 = 3x + 8y^2 - xy + 3.$

Ko'phad yoki birhadan ko'phadni ayirish uchun kamayuvchining yoniga ayiriluvchining hamma hadlarini qarama-qarshi ishora bilan yozish va o'xshash hadlari bo'lsa, ularni ixchamlash kerak.

Misol.  $(3a^2 + 2b - c) - (5b^2 + 4c - 5b) = 3a^2 + 2b - c - 5b^2 - 4c + 5b = 3a^2 - 5b^2 + (2 + 5)b - (1 + 4)c = 3a^2 - 5b^2 + 7b - 5c.$

Birhadni ko'phadga ko'paytirish uchun birhadni ko'phadning har bir hadiga ko'paytirib, hosil bo'lgan ko'paytmalarni qo'shish kerak.

Misol.  $(-2a^2c)(3a^2b^3 - 5ab^2c - \frac{2}{3}a^3b) = -6a^4b^3c + 10a^3b^2c^2 + \frac{4}{3}a^5bc.$

Ko'phadni ko'phadga ko'paytirish uchun birinchi ko'phadning har bir hadini ikkinchi ko'phadning har bir hadiga ko'paytirib, hosil bo'lgan ko'paytmalarni qo'shish kerak.

Misol.  $(0,1a^2 - 0,3a + 1)(3a^2 - 10) = 0,1a^2 \cdot 3a^2 - 0,1a^2 \cdot 10 - 0,3a \cdot 3a^2 + 0,3a \cdot 10 + 3a^2 - 10 = 0,3a^4 - a^2 - 0,9a^3 + 3a + 3a^2 - 10 = 0,3a^4 - 0,9a^3 + 2a^2 + 3a - 10.$



Birhadni birhadga bo'lish uchun:

– bo'linuvchining koeffitsiyentini bo'luvchining koeffitsiyentiga bo'lish;

– chiqqan bo'linma yoniga bo'linuvchidagi har bir harfni bo'linuvchi va bo'luvchidagi shu harflar ko'rsatkichlarining ayirmasiga teng ko'rsatkich bilan yozish;

– bo'linuvchining bo'luvchida bo'lmagan harflarini o'zgartirmasdan, bo'luvchining bo'linuvchida bo'lmagan harflarini esa daraja ko'rsatkichini qarama-qarshi ishora bilan yozish kerak.

Misollar. 1)  $(7a^3b^4c) : (8ab^2) = \frac{7}{8}a^2b^2c$ ;

2)  $(1,2xy^3z^n) : (-0,2xy^3z^2) = -6z^{n-2}$ ;

3)  $(81xy^2z^3) : (27xyc^2) = 3yz^3c^{-2}$ .

Ko'phadni birhadga bo'lish uchun ko'phadning har bir hadini shu birhadga bo'lish va chiqqan natijalarni qo'shish kerak.

Misol.  $(48a^3b^4 - 36a^4b^3 - 12ab^2) : (6ab^2) = 8a^2b^2 - 6a^3b - 2$ .

### 3-§. Qisqa ko'paytirish formulalari

Quyida keltirilgan ayniyatlar *qisqa ko'paytirish formulalari* deyiladi:

1)  $(a + b)^2 = a^2 + 2ab + b^2$  – yig'indining kvadrati.

2)  $(a - b)^2 = a^2 - 2ab + b^2$  – ayirmaning kvadrati.

3)  $a^2 - b^2 = (a - b)(a + b)$  – kvadratlar ayirmasi.

4)  $a^3 + b^3 = (a + b)(a^2 - ab + b^2)$  – kublarning yig'indisi.

5)  $a^3 - b^3 = (a - b)(a^2 + ab + b^2)$  – kublarning ayirmasi.

6)  $(a + b)^3 = a^3 + 3a^2b + 3ab^2 + b^3$  – yig'indining kubi.

7)  $(a - b)^3 = a^3 - 3a^2b + 3ab^2 - b^3$  – ayirmaning kubi.

Bu ayniyatlar ko'pgina hisoblash ishlarini yengillashtiradi, algebraik ifodalarni shakl almashtirishda qulayliklar yaratadi.

Misollar. 1)  $92 \cdot 88 = (90 + 2)(90 - 2) = 8100 - 4 = 8096$ ;

2)  $198^2 = (200 - 2)^2 = 40000 - 800 + 4 = 39204$ .

3)  $1,01^2 = (1 + 0,01)^2 = 1 + 2 \cdot 0,01 + 0,01^2 \approx 1 + 0,02 \approx 1,02$ .

4)  $(5a + \frac{1}{2}b)(5a - \frac{1}{2}b) = (5a)^2 - (\frac{1}{2}b)^2 = 25a^2 - \frac{1}{4}b^2$ .

5)  $(x^{2n} - 5y^n)(5y^n + x^{2n}) = (x^{2n} - 5y^n)(x^{2n} + 5y^n) = (x^{2n})^2 - (5y^n)^2 = x^{4n} - 25y^{2n}$ .

6)  $(x + 2y - 3z)^2 - (2x - y + z)^2 = (x + 2y - 3z - 2x + y - z) \times (x + 2y - 3z + 2x - y + z) = (3y - x - 4z)(3x + y - 2z)$ .

- 7)  $(5a^2 + 3b^3)^2 = 25a^4 + 30a^2b^3 + 9b^6$ .
- 8)  $(x + 2)(x^2 - 2x + 4) = x^3 + 8$ .
- 9)  $(7x^3y - 2z^2)(49x^6y^2 + 14x^3yz^2 + 4z^4) = (7x^3y)^3 - (2z^2)^3 =$   
 $= 343x^9y^3 - 8z^6$ .
- 10)  $(x + 2)(x - 2)(x^2 + 2x + 4)(x^2 - 2x + 4) = (x + 2)(x^2 - 2x + 4) \times$   
 $\times (x - 2)(x^2 + 2x + 4) = (x^3 + 8)(x^3 - 8) = (x^3)^2 - 8^2 = x^6 - 64$ .
- 11)  $(x^2 + 2)(x^4 - 2x^2 + 4) - x^6 + 8$  ifodani soddalashtirish natijasida hosil bo'lgan ko'phad nechta haddan iborat bo'ladi?
- Yechilishi:  $(x^2 + 2)(x^4 - 2x^2 + 4) - x^6 + 8 = (x^2)^3 + 2^3 -$   
 $- x^6 + 8 = x^6 - x^6 + 8 + 8 = 16$ . J a v o b: 1 ta haddan iborat bo'ladi.

#### 4-§. Ko'phadni ko'paytuvchilarga ajratish

Ko'phadni ko'paytuvchilarga ajratish deb, berilgan ko'phadni ikki yoki bir necha birhad va ko'phadlarning ko'paytmasiga aynan teng bo'lgan ifodaga almashtirishga aytiladi. Ko'phadni ko'paytuvchilarga ajratishning bir necha usullari bor.

**4.1. Umumiy ko'paytuvchini qavsdan tashqariga chiqarish usuli.** Bu usulda umumiy ko'paytuvchini topish, so'ngra qavsdan tashqariga chiqarish kerak.

Misollar: 1)  $48a^3b^2 + 36a^2b - 12a^4b^3 = 12a^2b \cdot 4ab + 12a^2b \cdot 3 -$   
 $- 12a^2b \cdot a^2b^2 = 12a^2b(4ab - a^2b^2 + 3)$ .

$$2) a^2(m-2) + b(2-m) = a^2(m-2) - b(m-2) = (m-2)(a^2 - b).$$

**4.2. Guruhlash usuli.** Ko'phadning hamma hadlari uchun umumiy ko'paytuvchi bo'lmagan holda guruhlash usuli qo'llaniladi. Ko'phadning hadlarini, ular ko'phad shaklidagi umumiy ko'paytuvchiga ega bo'ladigan qilib, guruhlarga birlashtiriladi va shu umumiy ko'paytuvchi qavsdan tashqariga chiqariladi.

1-m i s o l: 1)  $xy^2 - by^2 - ax + ab + y^2 - a$ . Ko'phadni ko'paytuvchilarga ajrating.

Y e c h i l i s h i. Bu ko'phadning hamma hadlari uchun umumiy ko'paytuvchi yo'q. Ko'phadni  $xy^2 - by^2 + y^2 - ax + ab - a$  ko'rinishda yozib, birinchi uchta haddan  $y^2$ , keyingi uchta hadlarda  $-a$  umumiy ko'paytuvchini qavsdan tashqari chiqarish mumkin bo'ladi. Shundan so'ng ko'phad ko'paytuvchiga ajratiladi:  $y^2(x - b + 1) -$   
 $- a(x - b + 1) = (x - b + 1)(y^2 - a)$ .

2-m i s o l: 1)  $m^2 - 3m + 2$  ni ko'paytuvchilarga ajrating.

**Yechilishi.** Ko'phadda umumiy ko'paytuvchi yo'q, guruhlash ham mumkin emas. Ammo  $-3m$  ni  $-m - 2m$  ko'rinishda yozsak, ko'phad  $m^2 - m - 2m + 2$  ko'rinishga keladi, endi bu ko'phadni guruhlab ko'paytuvchilarga ajratish mumkin:

$$m^2 - 3m + 2 = m^2 - m - 2m + 2 = m(m-1) - 2(m-1) = (m-1)(m-2).$$

### 4.3. Qisqa ko'paytirish formulalaridan foydalanib ko'paytuvchilarga ajratish usuli.

**Misollar.** Qisqa ko'paytirish formulalarini ko'phadlarni ko'paytuvchilarga ajratishdagi tatbiqini ushbu misollarda ko'rib chiqamiz:

- 1)  $36a^2b^4 - 25 = (6ab^2)^2 - 5^2 = (6ab^2 - 5)(6ab^2 + 5);$
- 2)  $4x^4 - 4x^2 + 1 = (2x^2)^2 - 2 \cdot 2x^2 + 1 = (2x^2 - 1)^2;$
- 3)  $25a^6 + 40a^5 + 16a^4 = (5a^3)^2 + 2 \cdot 5a^3 \cdot 4a^2 + (4a^2)^2 = (5a^3 + 4a^2)^2;$
- 4)  $27c^3 - 0,001d^6 = (3c)^3 - (0,01d^2)^3 = (3c - 0,1d^2)(9c^2 + 0,3cd^2 + 0,01d^4);$
- 5)  $125 + 8a^3b^{12} = 5^3 + (2ab^4)^3 = (5 + 2ab^4)(25 - 10ab^4 + 4a^2b^8);$
- 6)  $8 - 12c + 6c^2 - c^3 = 2^3 - 3 \cdot 2^2c + 3 \cdot 2c^2 - c^3 = (2 - c)^3;$
- 7)  $64d^6 + 27z^3 + 144d^4z + 108d^2z^2 = (4d^2)^3 + 3(4d^2)^2 \cdot 3z + 3 \cdot 4d^2 \cdot (3z)^2 + (3z)^3 = (4d^2 + 3z)^3.$

Ba'zan ko'phadni ko'paytuvchilarga ajratishda bir necha usullardan ketma-ket foydalanishga to'g'ri keladi.

**Misollar.** 1)  $a^3 + a^2 - 12 = a^3 + a^2 - 4 - 8 = a^3 - 8 + a^2 - 4 = a^3 - 2^3 + a^2 - 2^2 = (a-2)(a^2 + 2a + 4) + (a-2)(a+2) = (a-2)(a^2 + 2a + 4 + a + 2) = (a-2)(a^2 + 3a + 6);$

2)  $2a^2 - 5ab + 3b^2 = 2a^2 - 4ab - ab + 2b^2 + b^2 = 2a^2 - 4ab + 2b^2 + b^2 - ab = 2(b^2 - 2ab + a^2) + b(b-a) = 2(b-a)^2 + b(b-a) = (b-a) \times (2(b-a) + b) = (b-a)(2b-2a+b) = (b-a)(3b-2a);$

3)  $m^2 - 7m + 12 = m^2 - 3m - 4m + 12 = m(m-3) - 4(m-3) = (m-3)(m-4);$

4)  $(4a-1)^2 + 2(4a-1) + 1$ . Agar  $4a-1 = x$  belgilashni kiritsak, berilgan ifoda  $x^2 + 2x + 1$  ko'rinishga keladi, hosil bo'lgan ko'phadni (1) formula yordamida ko'paytuvchilarga ajratib, oxirgi natijada  $x$  ning o'rniga  $4a-1$  ikkihadni qo'yiladi.

$$(4a-1)^2 + 2(4a-1) + 1 = x^2 + 2x + 1 = (x+1)^2 = (4a-1+1)^2 = (4a)^2 = 16a^2.$$

5)  $x^4 + x^2 + 1 = x^2 + 2x^2 + 1 - x^2 = (x^2 + 1)^2 - x^2 = (x^2 + 1 - x) \times (x^2 + 1 + x) = (x^2 - x + 1)(x^2 + x + 1).$

## 5-§. Algebraik kasr

**Ta'rif:** Surat va maxraji algebraik ifodalardan iborat bo'lgan kasr algebraik kasr deyiladi.

Masalan,  $\frac{a}{a+1}$ ,  $\frac{a^2+5}{c}$ ,  $\frac{ax^2+bx}{cy}$ ,  $\frac{(a-3)(b-2)}{x+y}$  – algebraik kasrlardir.

Algebraik kasr maxrajining qiymati noldan farqli bo'lgan qiymatlarida ma'noga ega. Masalan,

- 1)  $\frac{a+b}{a-b}$  kasr  $a \neq b$  qiymatlarda aniqlangan.
- 2)  $\frac{a}{a(a-1)}$  kasr  $a = 0$  va  $a = 1$  qiymatlarda ma'noga ega bo'lmaydi.

Kasrning surat va maxrajini noldan farqli ifodaga ko'paytirish va bo'lish mumkin:

$$\frac{a}{b} = \frac{c \cdot a}{c \cdot b}, \text{ bu yerda } c \neq 0 \text{ va } b \neq 0.$$

**5.1. Algebraik kasrlarni qisqartirish.** Kasrning surat va maxrajida ishtirok etuvchi umumiy ko'paytuvchiga surat va maxrajini bo'lish kasrni *qisqartirish* deyiladi.

Misolalar. 1) 
$$\frac{m^2-n^2}{m^2+mn} = \frac{(m-n)(m+n)}{m(m+n)} = \frac{m-n}{m};$$

2) 
$$\frac{a^3-2a^2b}{2a^3b^2-a^4b} = \frac{a^2(a-2b)}{a^3b(2b-a)} = \frac{-a^2(2b-a)}{a^2(2b-a) \cdot ab} = -\frac{1}{ab};$$

3) 
$$\frac{a^2+b^2+c^2+2ab+2bc+2ac}{a^2-b^2-c^2-2bc} = \frac{(a+b+c)^2}{a^2-(b^2+2bc+c^2)} = \frac{(a+b+c)^2}{a^2-(b+c)^2} =$$
  

$$= \frac{(a+b+c)^2}{(a-(b+c))(a+b+c)} = \frac{(a+b+c)(a+b+c)}{(a-b-c)(a+b+c)} = \frac{a+b+c}{a-b-c};$$

4) 
$$\frac{a^4+a^3+4a^2+3a+3}{a^3-1} = \frac{a^4+a^3+a^2+3a^2+3a+3}{(a-1)(a^2+a+1)} =$$
  

$$= \frac{a^2(a^2+a+1)+3(a^2+a+1)}{(a-1)(a^2+a+1)} = \frac{(a^2+a+1)(a^2+3)}{(a^2+a+1)(a-1)} = \frac{a^2+3}{a-1}.$$

**5.2. Algebraik kasrlarni qo'shish.** Algebraik kasrlarni qo'shish va ayirishda oddiy kasrlarni qo'shish va ayirish amallarini bajarish kabi avval umumiy maxrajga keltirish kerak. Buning uchun avval har bir qo'shiluvchi kasrning maxraji ko'paytuvchiga ajratiladi:

$$\text{Misollar. 1) } \frac{5}{2x-2} + \frac{3}{4x-4} = \frac{5}{2(x-1)} + \frac{3}{4(x-1)} = \frac{5 \cdot 2}{2 \cdot 2(x-1)} +$$

$$+ \frac{3}{4(x-1)} = \frac{10}{4(x-1)} + \frac{3}{4(x-1)} = \frac{10+3}{4(x-1)} = \frac{13}{4(x-1)};$$

$$2) \frac{5b-1}{3b^2-3} + \frac{b+2}{2b+2} - \frac{b+1}{b-1} = \frac{5b-1}{3(b^2-1)} + \frac{b+2}{2(b+1)} - \frac{b+1}{b-1} = \frac{5b-1}{3(b-1)(b+1)} +$$

$$+ \frac{b+2}{2(b+1)} - \frac{b+1}{b-1} = \frac{2 \cdot (5b-1)}{2 \cdot 3(b-1)(b+1)} + \frac{(b+2) \cdot 3(b-1)}{2(b+1) \cdot 3(b-1)} - \frac{(b+1) \cdot 6(b+1)}{(b-1) \cdot 6(b+1)} =$$

$$= \frac{10b-2}{6(b^2-1)} + \frac{3(b^2-b+2b-2)}{6(b^2-1)} - \frac{6(b^2+2b+1)}{6(b^2-1)} = \frac{10b-2+3b^2+3b-6-6b^2-12b-6}{6(b^2-1)} =$$

$$= \frac{-3b^2+b-14}{6(b^2-1)};$$

$$3) a-2 + \frac{4a}{2+a} - \frac{a^3+ab}{a^2+2a} = \frac{a-2}{1} + \frac{4a}{2+a} - \frac{a^3+ab}{a(a+2)} = \frac{(a-2) \cdot a(a+2)}{a(a+2)} +$$

$$+ \frac{4a \cdot a}{a(2+a)} - \frac{a^3+ab}{a(a+2)} = \frac{a(a^2-4)+4a^2-a^3-ab}{a(a+2)} = \frac{a^3-4a+4a^2-a^3-ab}{a(a+2)} =$$

$$= \frac{4a^2-4a-ab}{a(a+2)} = \frac{a(4a-4-b)}{a(a+2)} = \frac{4a-b-4}{a+2}.$$

**5.3. Algebraik kasrlarni ko'paytirish va bo'lish.** Algebraik kasrlarni ko'paytirish va bo'lish oddiy kasrlarni ko'paytirish va bo'lish qoidalari bo'yicha bajariladi:

$$\frac{a}{b} \cdot \frac{c}{d} = \frac{a \cdot c}{b \cdot d}; \quad \frac{a}{b} : \frac{c}{d} = \frac{a}{b} \cdot \frac{d}{c} = \frac{a \cdot d}{b \cdot c}.$$

Misollar.

$$1) \frac{4m}{9n} \cdot \frac{27k}{16d} = \frac{4 \cdot 27 \cdot m \cdot k}{9 \cdot 16 \cdot n \cdot d} = \frac{3mk}{4nd};$$

$$2) \frac{a^2-b^2}{3a+3b} \cdot \frac{3a^2}{5b-5a} = \frac{(a-b)(a+b) \cdot 3a^2}{3(a+b) \cdot 5(b-a)} = \frac{(a^2-b^2) \cdot 3a^2}{-15 \cdot (a^2-b^2)} = -\frac{a^2}{5};$$

$$3) \frac{a-b}{9b^2} : \frac{a-b}{6b^2} = \frac{a-b}{9b^2} \cdot \frac{6b^2}{a-b} = \frac{2 \cdot 3b^2(a-b)}{3 \cdot 3b^2(a-b)} = \frac{2}{3};$$

$$4) \frac{b^2-8b+16}{b+3} : \frac{(b-4)^2}{b^2-9} = \frac{(b-4)^2}{b+3} \cdot \frac{b^2-9}{(b-4)^2} = \frac{(b-4)^2(b-3)(b+3)}{(b+3)(b-4)^2} = b-3;$$

#### 5.4. Algebraik kasrlar ustida birgalikda bajariladigan amallar.

Algebraik kasrlar ustida birgalikda bajariladigan amallar uchun sonli kasrlar ustida bajariladigan amallarning tartib va qoidalari to'liq saqlanadi.

Misollar.

1. Ifodani soddalashtiring:  $\left(\frac{a+b}{a-b} - \frac{a-b}{a+b}\right) : \left(\frac{a-b}{a+b} + \frac{a+b}{a-b}\right) - 1$ .

Yechilishi. Amallarni bajarilish tartibi bo'yicha bajaramiz. Dastlab qavslar ichidagi ifodalarni soddalashtiramiz:

$$1) \frac{a+b}{a-b} - \frac{a-b}{a+b} = \frac{(a+b)^2 - (a-b)^2}{(a-b)(a+b)} = \frac{a^2 + 2ab + b^2 - a^2 + 2ab - b^2}{a^2 - b^2} = \frac{4ab}{a^2 - b^2};$$

$$2) \frac{a-b}{a+b} + \frac{a+b}{a-b} = \frac{(a-b)^2 + (a+b)^2}{(a+b)(a-b)} = \frac{a^2 - 2ab + b^2 + a^2 + 2ab + b^2}{a^2 - b^2} = \frac{2(a^2 + b^2)}{a^2 - b^2};$$

3) Endi bo'lish amalini bajaramiz:

$$\frac{4ab}{a^2 - b^2} : \frac{2(a^2 + b^2)}{a^2 - b^2} = \frac{4ab}{a^2 - b^2} \cdot \frac{a^2 - b^2}{2(a^2 + b^2)} = \frac{2ab}{a^2 + b^2};$$

4) Bo'linmadan birni ayiramiz:

$$\frac{2ab}{a^2 + b^2} - 1 = \frac{2ab - a^2 - b^2}{a^2 + b^2} = -\frac{a^2 - 2ab + b^2}{a^2 + b^2} = -\frac{(a-b)^2}{a^2 + b^2}.$$

J a v o b:  $-\frac{(a-b)^2}{a^2 + b^2}$ .

2. Ifodani soddalashtiring:

$$\left(\frac{ax-b}{a+b} - \frac{bx+a}{b-a}\right) \cdot \left(\frac{a^2-b^2}{x^2-1} : \frac{a^2+b^2}{x-1}\right).$$

Yechilishi. Ko'pgina hollarda amallarning bajarilish tartibini yodda tutgan holda ularni birgalikda ketma-ket bajarib borish maqsadga muvofiqdir:

$$\begin{aligned} & \left( \frac{ax-b}{a+b} - \frac{bx+a}{b-a} \right) \cdot \left( \frac{a^2-b^2}{x^2-1} \cdot \frac{a^2+b^2}{x-1} \right) = \frac{(ax-b)(b-a) - (bx+a)(b+a)}{(b+a)(b-a)} \times \\ & \times \frac{a^2-b^2}{(x-1)(x+1)} \cdot \frac{x-1}{a^2+b^2} = \frac{abx - a^2x - b^2 + ab - b^2x - abx - ab - a^2}{b^2 - a^2} \times \\ & \times \frac{a^2-b^2}{(a^2+b^2)(x+1)} = \frac{-x(a^2+b^2) - (a^2+b^2)}{a^2-b^2} \cdot \frac{a^2-b^2}{(a^2+b^2)(x+1)} = \frac{(a^2+b^2)(x+1)}{(a^2+b^2)(x+1)} = 1. \end{aligned}$$

J a v o b: 1.

3. Ifodani soddalashtiring va uning  $a = 0,5$  dagi qiymatini hisoblang:

$$\frac{x}{ax-2a^2} - \frac{2}{x^2+x-2ax-2a} \cdot \left( 1 + \frac{3x+x^2}{x+3} \right)$$

Y e c h i l i s h i: 1) Ifodani soddalashtiramiz:

$$\begin{aligned} & \frac{x}{ax-2a^2} - \frac{2}{x^2+x-2ax-2a} \cdot \left( 1 + \frac{3x+x^2}{x+3} \right) = \frac{x}{a(x-2a)} - \frac{2}{x(x+1)-2a(x+1)} \times \\ & \times \frac{x+3+x(x+3)}{x+3} = \frac{x}{a(x-2a)} - \frac{2}{(x+1)(x-2a)} \cdot \frac{(x+3)(x+1)}{x+3} = \frac{x}{a(x-2a)} - \\ & - \frac{2}{x-2a} = \frac{x-2a}{a(x-2a)} = \frac{1}{a}. \end{aligned}$$

2) Ifodaning  $a = 0,5$  dagi qiymatini hisoblaymiz:

$$\frac{1}{a} \Big|_{a=0,5} = \frac{1}{0,5} = 2.$$

J a v o b: 2.

### Mustaqil ilshash uchun test topshiriqlari

1.  $2^2 \cdot 4^8 \cdot 8^2 \cdot \left(\frac{1}{16}\right)^5$  ni hisoblang.

A) 24;      B) 64;      C) 16;      D) 82;      E) 8.

2.  $(1,7)^{-3} \cdot 9^0 \cdot (5,1)^{-3} \cdot 6^{-3}$  ni hisoblang.

- A) 3;      B)  $\frac{1}{8}$ ;      C)  $\frac{3}{4}$ ;      D) 0,2;      E)  $\frac{3}{8}$ .

3\*. Soddalashtiring:  $\frac{(8^{k+1}+8^k)^2}{(4^k-4^{k-1})^3}$ .

- A)  $\frac{8^k}{4^{k-1}}$ ;      B)  $\frac{8^{k+1}}{4^{k+1}}$ ;      C) 192;      D)  $\frac{k-1}{k}$ ;      E) 200.

4.  $\left(\frac{-16x^{31}}{9y^3}\right)^3 : \left(\frac{-8x^{23}}{3y^2}\right)^4$  ni soddalashtiring.

- A)  $-\frac{y}{x}$ ;      B)  $-\frac{x}{y}$ ;      C)  $\frac{x}{9y}$ ;      D)  $-\frac{y}{9x}$ ;      E)  $-\frac{x}{9y}$ .

5. Hisoblang:  $\frac{2^{-2} \cdot 5^3 \cdot 10^{-4}}{2^{-3} \cdot 5^2 \cdot 10^{-5}}$ .

- A) 100;      B) 0,01;      C) 2;      D) 5;      E) 10.

6. Hisoblang:  $\frac{10^{50}+10^{55}+10^{60}+10^{65}}{10^{60}+10^{55}+10^{50}+10^{45}}$ .

- A)  $10^{10}$ ;      B)  $10^5$ ;      C)  $10^4$ ;      D)  $10^3$ ;      E)  $10^2$ .

7.  $243^{-1}$  sonini 3 asosli daraja shaklida yozing.

- A) yozib bo'lmaydi;      B)  $3^{-4}$ ;      C)  $3^{-5}$ ;      D)  $3^{-6}$ ;      E)  $3^{-9}$ .

8.  $\left(-\frac{4}{6}\right) \cdot \left(\frac{8}{6}\right)^3 \cdot \left(-\frac{3}{2}\right)^2 \cdot (0,75)^3$  ni hisoblang.

- A) 1,5;      B) 1,75;      C) -2,75;      D) -2;      E) -1,5.

9. Hisoblang:  $64^4 \cdot 125^8 \cdot 100^{12}$ .

- A)  $10^{18}$ ;      B)  $10^{24}$ ;      C)  $10^{36}$ ;      D)  $10^{48}$ ;      E)  $10^{64}$ .

10\*.  $2^n \cdot 5^m = 20$ ,  $2^m \cdot 5^n = 5000$  bo'lsa,  $n + m$  nechaga teng?

- A) 4;      B) 5;      C) 6;      D) 7;      E) 8.

11. Amalni bajaring:  $(-0,2b^9)^3 \cdot b$ .

- A)  $-0,6b^{18}$ ;      B)  $-0,008b^{19}$ ;      C)  $0,008b^9$ ;      D)  $0,008b^{18}$ ;      E)  $-0,6b^{10}$ .

12.  $10x^2y - 5xy^2 - 2x^2y + x^2y - 3xy^2$  ko'phadning standart shakli nechta haddan iborat?

- A) 4;      B) 3;      C) 2;      D) 5;      E) 1.

13.  $\frac{4}{9}\left(4\frac{1}{2}y - 1\frac{1}{2}\right) - \frac{2}{7}\left(1\frac{1}{6} - 3\frac{1}{2}y\right)$  ni soddalashtiring.

- A)  $0,2y - 1$ ;      B)  $2y + 1$ ;      C)  $3y - 1$ ;      D)  $\frac{2}{3}y - \frac{1}{3}$ ;      E)  $y - 1$ .

14.  $P = 13x^n + 8y^m - 11xy - 5$  va  $Q = 7x^n - 3y^m + 3xy - 4$  ko'phadlar ayirmasini toping.



- A)  $6x^n + 5y^m - 8xy - 9$ ; B)  $6x^n + 11y^m - 14xy - 1$ ;  
 C)  $20x^n + 11y^m - 8xy - 9$ ; D)  $6x^n + 10x^{p+m} - 14xy + 1$ ;  
 E)  $10x^{p+m} - 14xy - 1$ .

15.  $\left(-\frac{2}{7}ab^4\right)^2 \cdot \left(-3\frac{1}{2}a^3b\right)^2$  ko'paytmani toping.

- A)  $3\frac{2}{14}a^5b^8$ ; B)  $a^8b^{10}$ ; C)  $a^7b^8$ ; D)  $-a^8b^{10}$ ; E)  $a^5b^8$ .

16.  $(a + 3b)(a + b + 2) - (a + b)(a + 3b + 2)$  ifodani soddalash-tiring.

- A)  $2a - b$ ; B)  $a - 2b$ ; C)  $4a + 2b$ ; D)  $4b$ ; E)  $6ab$ .

17.  $(3x^2 + 5x + 11)(8x - 6 + 2x^2)$  ko'paytmani ko'phadning standart shaklida yozing.

- A)  $10x^3 + 44x^2 - 66$ ; B)  $6x^4 + 34x^3 + 44x^2 + 58x - 66$ ;  
 C)  $6x^4 + 34x^3 - 34x^2 - 66$ ; D)  $6x^4 + 34x^3 + 50x - 66$ ;  
 E)  $6x^4 + 34x^3 - 34x^2 + 30x - 66$ .

18. Bo'linmani toping:  $(a^{n+1})^3 : (a^{n-1})^2$ .

- A)  $a^n$ ; B)  $a^{2n+1}$ ; C)  $a^{n+5}$ ; D)  $a^{n+1}$ ; E)  $a^{2n+5}$ .

19.  $n \in N$  bo'lsa, bo'linmani toping:  $(z^{n-2})^{n-3} : (z^{n-6})^{n-1}$

- A)  $z^{n+1}$ ; B)  $z^{2n+12}$ ; C)  $z^{2n}$ ; D)  $z^{n^2}$ ; E)  $z^{n(n-2)}$ .

20.  $n \in N$ . Bo'linmani toping:

$$(3x^{2n}y^{3n+1} - 2x^{2n+1}y^{3n-1} - 5x^{3n-1}y^{3n}) : (-2x^{2n-2}y^{3n-1}).$$

- A)  $-\frac{3}{2}x^{-2} + x^{-1}y^{-1} + \frac{5}{2}x^{n-1}y^{-1}$ ; D)  $-\frac{3}{2}x^2y + x^3 + \frac{5}{2}x^{n+4}y$ ;  
 B)  $-\frac{3}{2}x^2y^2 + x^3 + \frac{5}{2}x^{n+1}y$ ; E)  $-\frac{3}{2}x^{-2} + x^3y + \frac{5}{2}x^{n+1}y^2$ .  
 C)  $-\frac{3}{2}xy + x^2y^2 + \frac{5}{2}x^n y$ ;

21.  $(2z - c)(4z^2 + 2zc + c^2) - c^2$  ifoda ko'phadning standart shak-liga keltirilsa, u nechta haddan iborat bo'ladi?

- A) 5; B) 4; C) 3; D) 2; E) 7.

22.  $x = 3^3 + 3^{-3}$  va  $y = 3^3 - 3^{-3}$  bo'lsa,  $x^2 - y^2$  ning qiymatini toping.

- A) 0; B) 3; C)  $\frac{1}{3}$ ; D) 9; E) 4.

23.  $7c - 14d$  ni ko'paytuvchilarga ajrating.

- A)  $7(c - 14d)$ ; B)  $7(c - 2d)$ ; C)  $7(2d - c)$ ; D)  $(3c - 2d)(4 - 7d)$ ;  
 E)  $7(c - 7d)$ .

24.  $b^2 + ab - 2a^2 - b + a$  ko'phadni ko'paytuvchilarga ajrating.

A)  $(a - b)(2a - b)$ ; B)  $(a + b)(2a - b - 1)$ ; C)  $(a - b)(2a - b - 1)$ ;  
D)  $(b - 2a)(a - b + 1)$ ; E)  $(b - a)(2a + b - 1)$ .

25.  $3x^2 - 6xm - 9m^2$  ko'phadni ko'paytuvchilarga ajrating.

A)  $3(x + m)(x - 3m)$ ; B)  $(x - 3m)^2$ ; C)  $3(x - m)(x + 3m)$ ;

D)  $3(x - m)^2$ ; E)  $3(x - 3m)(x - m)$ .

26.  $a^5 + a^4 - 2a^3 - 2a^2 + a + 1$  ko'phadni ko'paytuvchilarga ajrating.

A)  $(a + 1)^2(a - 1)^3$ ; B)  $(a + 1)^3(a - 1)^2$ ; C)  $(a + 1)^4(a - 1)$ ;

D)  $(a + 1)(a - 1)^4$ ; E)  $(a^2 + 1)^2(a - 1)$ .

27\*.  $(x - y)^3 - (z - y)^3 + (z - x)^3$  ifodani ko'paytma shaklida yozing.

A)  $3(x - y)(y - z)(x - z)$ ; B)  $-3(x - y)(z - y)(x - z)$ ;

C)  $3(y - x)(y - z)(z - x)$ ; D)  $-3(x - y)(z - y)(z - x)$ ;

E) Ko'paytuvchilarga ajratib bo'lmaydi.

28\*.  $a^4 + a^3 + 4a^2 + 3a + 3$  ni ko'paytuvchilarga ajrating.

A)  $(a^2 + 3)(a^2 + 1)$ ; B)  $(a^2 + 2a + 3)(a^2 + 1)$ ; C)  $(a + 1)^2(a^2 + 3)$ ;

D)  $(a^2 + 3)(a^2 + a + 1)$ ; E)  $(a + 3)(a^3 + a^2 + 1)$ .

29.  $\frac{a^8 - a^4}{a^4 + a^2}$  kasrni qisqartiring.

A)  $a^6 + a^2$ ; B)  $a^4 - a^2$ ; C)  $a^6 + a^2$ ; D)  $a^4 + a^2$ ; E)  $a^2 - a^4$ .

30\*.  $\frac{x^3 - 1}{x^4 + x^2 + 1}$  kasrni qisqartiring.

A)  $\frac{x}{x+2}$ ; B)  $\frac{x-1}{x^2+x+1}$ ; C)  $\frac{x+1}{x^2-x+1}$ ; D)  $\frac{x-1}{x^2-x+1}$ ; E)  $\frac{x-1}{x^2-x-1}$ .

31\*.  $\frac{a^3 - 2a^2 + 5a + 26}{a^3 - 5a^2 + 17a - 13}$  kasrni qisqartiring.

A)  $\frac{a^2 + 4a + 26}{a^2 - 4a + 13}$ ; B)  $\frac{a-1}{a+2}$ ; C)  $\frac{a+2}{a-1}$ ; D)  $\frac{a-2}{a+1}$ ; E)  $\frac{a^2 - 4a + 26}{a^2 - 4a - 13}$ .

32.  $\frac{a-2}{a+2} + \frac{a+2}{a-2}$  ni soddalashtiring.

A) 1; B) 2; C)  $\frac{2a^2+8}{a-4}$ ; D)  $\frac{2(a^2+4)}{a^2-4}$ ; E)  $\frac{8ab}{4-a^2}$ .

33. Soddalashtiring:  $\frac{21y^2+1}{1-9y^2} - \frac{y}{3y-1}$ .

A)  $\frac{21y^2 - y + 1}{2 - 9y^2 - 3y}$ ; B)  $\frac{21y^2 - y + 1}{2 - 9y^2 + 3y}$ ; C)  $\frac{24y^2 + 3y - 1}{1 - 9y^2}$ ;

D)  $\frac{24y^2 - 1}{1 - 9y^2}$ ; E)  $\frac{24y^2 + y + 1}{1 - 9y^2}$ .

34. Ifodani soddalashtiring:  $\frac{6a}{9a^2 - 1} + \frac{3a + 1}{3 - 9a} + \frac{3a - 1}{6a + 2}$ .

A)  $\frac{3a - 1}{3a + 1}$ ; B)  $\frac{6(3a - 1)}{3a + 1}$ ; C)  $\frac{3a + 1}{3a - 1}$ ; D)  $\frac{3a + 1}{6(3a - 1)}$ ; E)  $\frac{3a + 2}{6(9a^2 - 1)}$ .

35. Ifodani soddalashtiring:  $\frac{a^2 + 4}{a^3 + 8} - \frac{1}{a + 2}$ .

A)  $\frac{a^2 + 3}{a^3 + 8}$ ; B)  $\frac{a^2 + 2a + 2}{a^3 + 8}$ ; C)  $\frac{2a}{a^3 + 8}$ ; D)  $\frac{a^2 - 1}{a^3 + 8}$ ; E)  $-\frac{2a}{a^3 + 8}$ .

36.  $\frac{x^2 - xy}{a^2b - b^3} \cdot \frac{a^2 + 2ab + b^2}{x - 2xy + y^2}$  ni soddalashtiring.

A)  $\frac{x(a + b)}{b(a - b)(x + y)}$ ; B)  $\frac{x(a + b)}{b(b - a)(x + y)}$ ; C)  $\frac{x(a + b)}{b(a - b)(x - y)}$ ;

D)  $\frac{x(a - b)}{b(x - y)}$ ; E)  $\frac{a + b}{b(x - y)}$ .

37.  $\frac{ab + b^2}{9x^2 - 4z^2} : \frac{a^3 + 2a^2b + ab^2}{2z^2 - 3xz}$  ni soddalashtiring.

A)  $\frac{b}{(a + b)(3x + 2z)}$ ; B)  $-\frac{b}{(a + b)(3x + 2z)}$ ; C)  $-\frac{bz}{(a + b)(3x + 2z)}$ ;

D)  $-\frac{bz}{a(a + b)(3x + 2z)}$ ; E)  $\frac{bz}{a(a + b)(3x + 2z)}$ .

38. Ifodani soddalashtiring:  $\frac{a^2 - 2a + 1}{2a^2 + 1} : \frac{a - 1}{4a^4 - 1}$ .

A)  $(a - 1)(2a^2 - 1)$ ; B)  $(a - 1)(2a^2 + 1)$ ; C)  $\frac{(a - 1)(2a^2 - 1)}{2a^2 + 1}$ ;

D)  $a - 1$ ; E)  $(a - 1)(a^2 - 2)$ .

39. Ifodani soddalashtiring:

$\left( \frac{a - 1}{3a + (a - 1)^2} - \frac{1 - 3a + a^2}{a^3 - 1} - \frac{1}{a - 1} \right) : \frac{a^2 + 1}{1 - a}$ .

A)  $\frac{a-1}{a^2+1}$ ; B)  $\frac{a^2+1}{a-1}$ ; C)  $\frac{2a}{a^2+a+1}$ ; D)  $\frac{1}{a^2+a+1}$ ; E)  $\frac{a+1}{a-1}$ .

40. Ifodani soddalashtiring:

$$\left( \frac{a^2-ab}{a^2b+b^3} - \frac{2a^2}{b^3-ab^2+a^2b-a^3} \right) \left( 1 - \frac{b-1}{a} - \frac{b}{a^2} \right).$$

A)  $\frac{ab}{a+1}$ ; B)  $\frac{a+1}{ab}$ ; C)  $\frac{a+1}{a-b}$ ; D)  $\frac{a+1}{a+b}$ ; E)  $\frac{b+1}{ab}$ .

41. Ifodani soddalashtiring:

$$\left( \frac{1}{x^2} + \frac{1}{y^2} + \frac{2}{x+y} \cdot \left( \frac{1}{x} + \frac{1}{y} \right) \right) : \frac{x^3+y^3}{x^2y^2}.$$

A)  $\frac{1}{x^2-xy+y^2}$ ; B)  $\frac{x+y}{xy(x^2+xy+y^2)}$ ; C)  $\frac{(x+y)^2}{x^2+xy+y^2}$ ;

D)  $\frac{x+y}{x^2+xy+y^2}$ ; E)  $\frac{x+y}{x^2-xy+y^2}$ .

42. Ifodani soddalashtiring:

$$\left( \frac{a^2}{a^2-b^2} - \frac{a^2b}{a^2+b^2} \cdot \left( \frac{a}{ab+b^2} + \frac{b}{a^2+ab} \right) \right) : \frac{b}{a-b}.$$

A)  $-\frac{a}{a+b}$ ; B)  $\frac{a}{a+b}$ ; C)  $\frac{1}{a+b}$ ; D)  $-\frac{1}{a+b}$ ; E)  $\frac{a+b}{a^2+b^2}$ .

43. Ifodani soddalashtiring:

$$\left( \frac{p^2-q^2}{pq} - \frac{1}{p+q} \cdot \left( \frac{p^2}{q} - \frac{q^2}{p} \right) \right) : \frac{p-q}{p}.$$

A)  $-\frac{p}{p+q}$ ; B)  $\frac{p}{p-q}$ ; C)  $\frac{p+q}{pq}$ ; D)  $\frac{p}{p+q}$ ; E)  $\frac{q}{p+q}$ .

44\*. Ifodani soddalashtiring:

$$\left( \frac{b^2+c^2}{b^2c^2} \cdot \left( \frac{1}{b^2} - \frac{1}{c^2} \right) - \left( \frac{1}{a^2} - \frac{1}{c^2} \right) \cdot \frac{a^2+c^2}{a^2c^2} \right) : \frac{a^2+b^2}{a^2b^2}.$$

A)  $\frac{a^2-b^2}{a^2b^2}$ ; B)  $\frac{a^2-b^2}{a^2+b^2}$ ; C)  $\frac{a^2b^2}{a^2-b^2}$ ; D)  $\frac{a-b}{ab}$ ; E)  $\frac{a+b}{ab}$ .

45. Ifodani soddalashtiring:

$$\left( \frac{2}{3x} - \frac{2}{x+y} \cdot \left( \frac{x+y}{3x} - x - y \right) \right) : \frac{x-y}{x}.$$

A)  $\frac{x}{x-y}$ ; B)  $\frac{2x}{x-y}$ ; C)  $\frac{2x}{y-x}$ ; D)  $\frac{1}{x-y}$ ; E)  $\frac{2}{x-y}$ .

46. Ifodani soddallashtiring:

$$\frac{xy}{x+y} : \left( \frac{x^2}{(x^2-y^2)(x+y)} - \frac{2xy^2}{x^2-2x^2y^2+y^2} + \frac{y^2}{(x-y)^2(x+y)} \right)$$

- A)  $\frac{1}{xy}$ ; B)  $\frac{1}{x+y}$ ; C)  $xy$ ; D)  $x+y$ ; E)  $\frac{xy}{x+y}$ .

47. Ifodani soddallashtiring:

$$\frac{a^2+b^2}{ab} : \left( \frac{6a+b}{a^2-b^2} ; \frac{6a^3+b^3+a^2b+6ab^2}{2ab^2-2a^2b} + \frac{a+b}{a^2+b^2} \right)$$

- A)  $\frac{a^2+b^2}{ab(a+b)}$ ; B)  $\frac{a+b}{ab}$ ; C)  $\frac{a^2+b^2}{a-b}$ ; D)  $\frac{a^2+b^2}{a+b}$ ; E)  $ab$ .

48. Ifodani soddallashtiring:

$$\left( \frac{2x^2y+2xy^2}{7x^3+x^2y+7xy^2+y^3} \cdot \frac{7x+y}{x^2-y^2} + \frac{x-y}{x^2+y^2} \right) \cdot (x^2-y^2)$$

- A)  $\frac{x+y}{x-y}$ ; B)  $\frac{x-y}{x+y}$ ; C)  $xy$ ; D)  $\frac{x+y}{xy}$ ; E)  $x+y$ .

49. Ifodani soddallashtiring:

$$\left( \frac{5}{a^2-2a-ax+2x} - \frac{1}{8-8a+2a^2} \times \frac{20-10a}{x-2} \right) : \frac{25}{x^3-8}$$

- A)  $\frac{(x+2)^2}{5(a-x)}$ ; B)  $\frac{x^2+2x+4}{5(a-x)}$ ; C)  $\frac{x^2+x+4}{5(x-a)}$ ; D)  $\frac{x+2}{5(x-a)}$ ;

E)  $\frac{(x-2)^2}{5(a-x)}$ .

50. Ifodani soddallashtiring:

$$\left( \frac{3a}{9-3x-3a+ax} - \frac{1}{a^2-9} ; \frac{x-a}{3a^2+9a} \right) \cdot \frac{x^3-27}{3a}$$

- A)  $\frac{(x+3)^2}{a-x}$ ; B)  $\frac{x^2+x+9}{a-x}$ ; C)  $\frac{x^2+3x+9}{a-x}$ ; D)  $\frac{(x-3)^2}{a-x}$ ;

E)  $\frac{x^2+3x+9}{x-a}$ .

CHIZIQLI TENGLAMALAR  
VA TENGSIZLIKLAR

1-§. Bir noma'lumli tenglamalar

T a' r i f. Agar

$$f(x) = \varphi(x) \quad (1)$$

tenglikka nisbatan o'zgaruvchi  $x$  ning (1) ni to'g'ri tenglikka aylantiradigan barcha qiymatlarni topish masalasi qo'yilgan bo'lsa, u holda (1) tenglik bir noma'lumli tenglama deyiladi.

O'zgaruvchining tenglamani to'g'ri tenglikka aylantiradigan qiymatlari tenglamaning ildizlari deyiladi.

Tenglamani yechish – bu uning ildizlari to'plamini topish yoki ularning mavjud emasligini isbotlashdan iboratdir.

(1) tenglikda  $x$  o'zgaruvchining bir paytda  $f(x)$  va  $\varphi(x)$  ma'noga ega bo'ladigan qiymatlar to'plami *tenglamaning aniqlanish sohasi* deyiladi.

T a' r i f. Berilgan sonlar to'plamidagi bir tenglamaning har bir ildizi ikkinchi tenglamaning ildizi bo'lsa va aksincha ham bo'lsa, u holda bu ikki tenglama teng kuchli yoki ekvivalent tenglamalar deyiladi va  $\Leftrightarrow$  belgi bilan tasvirlanadi.

Agar ikki tenglamaning har biri berilgan sonlar to'plamida yechimga ega bo'lmasa ham ular shu to'plamda teng kuchli hisoblanadi.

Agar  $f(x) = \varphi(x)$  tenglamaning ikkala qismiga ham o'zgaruvchining mumkin bo'lgan qiymatlarida biror  $A(x)$  ( $A(x) = \text{const}$  bo'lishi ham mumkin) ifoda qo'shilsa, yoki ayirilsa, berilgan tenglamaga teng kuchli tenglama hosil bo'ladi:

$$f(x) = \varphi(x) \Leftrightarrow f(x) + A(x) = \varphi(x) + A(x).$$

Ixtiyoriy qo'shiluvchini tenglamaning o'ng qismidan chap qismiga va aksincha, chap qismidan o'ng qismiga teskari ishora bilan o'tkazish mumkin.

Agar (1) tenglamaning ikkala qismini o'zgaruvchining mumkin bo'lgan qiymatlari to'plamida aniqlangan biror  $A(x) \neq 0$  ( $A(x)$  –

const bo'lishi ham mumkin) ifodaga ko'paytirish (bo'lish) natijasida berilgan tenglamaga teng kuchli tenglama hosil bo'ladi:

$$f(x) = \varphi(x) \Leftrightarrow A(x)f(x) = A(x)\varphi(x)$$

yoki 
$$f(x) = \varphi(x) \Leftrightarrow \frac{f(x)}{A(x)} = \frac{\varphi(x)}{A(x)}$$

## 2-§. Birinchi darajali bir noma'lumli tenglamalar

**T a' r i f.**  $ax + b = 0$  ko'rinishidagi tenglama birinchi darajali bir noma'lumli tenglama deyiladi. Bunda  $a$  va  $b$  haqiqiy sonlar bo'lib ( $a \neq 0$ ),  $a$  – tenglama koeffitsiyenti,  $b$  – ozod had,  $x$  – noma'lum deyiladi.

Bu tenglamaning yechimi

$$x = -\frac{b}{a}$$

Agar  $a \neq 0$  bo'lsa, tenglama yechimi yagona,  $a = 0$ ,  $b \neq 0$  da yechim mavjud emas,  $a = b = 0$  bo'lsa, tenglama cheksiz ko'p yechimga ega.

1-misol.  $2.5(x - 4) = 4.5x + 1$  tenglamani yeching.

Yechilishi:  $2.5(x - 4) = 4.5x + 1 \Leftrightarrow 2.5x - 10 = 4.5x + 1 \Leftrightarrow$

$$-2x = 11 \Rightarrow \left[ x = -\frac{11}{2} = -5.5; \right] \text{ J a v o b: } -5.5.$$

2-misol.  $\frac{2(x-4)}{3} + \frac{3x+13}{8} = \frac{3(2x-3)}{3} - 7$  tenglamani yeching.

**Y e c h i l i s h i.** Bunday tenglamalarni yechishda odatda o'quvchilar tenglamaning har ikkala tomoniga alohida-alohida umumiy maxraj berib, so'ngra maxrajni tashlab yuborishadi. Oqibatda, shoshilib, tenglamani qanoatlantirmaydigan yechimlarni topib, ularni ildiz deb javob belgilashadi. Shunday xatolikka yo'l qo'ymaslik uchun dastlabki tenglikning o'ng tomonidagi (chap tomondagi) ifodani chap tomonga (o'ng tomonga) o'tkazib, so'ngra bu ifodani nolga tenglashtirishdan hosil bo'lgan tenglama hadlari umumiy maxrajga keltirib yechilsa, bunday xatolikning oldi olingan bo'ladi:

$$\begin{aligned} \frac{2(x-4)}{3} + \frac{3x+13}{8} &= \frac{3(2x-3)}{3} - 7 \Leftrightarrow \frac{2x-8}{3} + \frac{3x+13}{8} - \frac{6x-9}{3} + 7 = 0 \Leftrightarrow \\ \Leftrightarrow 16x - 64 + 9x + 39 - 48x + 72 + 168 &= 0 \Leftrightarrow \end{aligned}$$

$$-23x + 215 = 0 \Rightarrow [x = 9 \frac{8}{23}]. \text{ J a v o b: } 9 \frac{8}{23}.$$

3-misol.  $17(2 - 3x) - 5(x + 12) = 8(1 - 7x)$  tenglamani yeching.

$$\text{Yechilishi: } 17(2 - 3x) - 5(x + 12) = 8(1 - 7x) \Leftrightarrow 34 - 51x - 5x - 60 = 8 - 56x \Leftrightarrow x(56 - 56) = 34 \Leftrightarrow 0 \cdot x = 34.$$

Demak, berilgan tenglama yechimga ega emas.

J a v o b: tenglamaning ildizlari yo'q.

### 3-§. Tekislikda to'g'ri burchakli koordinatalar sistemasi

Tekislikda biror nuqtaning aniq vaziyatini ifodalashning bir necha yo'li mavjud bo'lib, umumta'lim maktablarida shulardan to'g'ri burchakli Dekart koordinatalar sistemasi o'rganiladi.



5-rasm

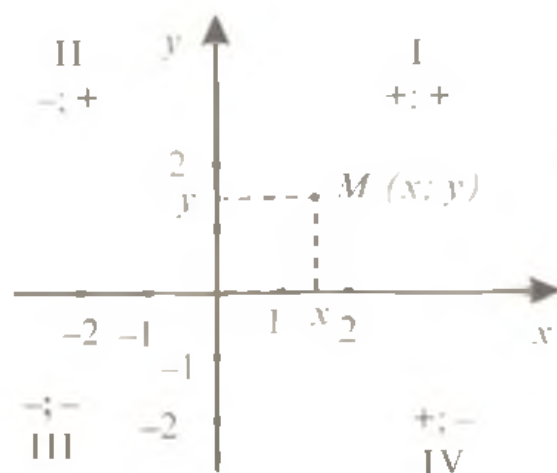

6-rasm

Tekislikda ikkita o'zaro perpendikular, biri gorizontalar, ikkinchisi vertikal to'g'ri chiziqlarni chizamiz va ularning kesishish nuqtasini  $O$  harfi bilan belgilaymiz. Bu to'g'ri chiziqlarda yo'nalishlar tanlaymiz: gorizontalarida – o'ngga, vertikalida – yuqoriga. Har bir to'g'ri chiziqda bir xil uzunlik birligini ajratamiz (5-rasm).

Gorizontalar to'g'ri chiziq  $Ox$  bilan belgilanadi va *absissalar o'qi* deyiladi; vertikal to'g'ri chiziq  $Oy$  bilan belgilanadi va *ordinatalar o'qi* deyiladi. Absissalar o'qi va ordinatalar o'qini *koordinata o'qlari*, ularning kesishish nuqtasini *koordinatalar boshi* deyiladi. Koordinatalar boshi har bir o'qdagi nol sonini tasvirlaydi.

Absissalar o'qida musbat sonlar  $O(0;0)$  nuqtadan o'ngda, manfiy sonlar esa chapda tasvirlanadi. Ordinatalar o'qida musbat sonlar koordinatalar boshidan yuqorida, manfiylari pastda tasvirlanadi.



Tekislikda ixtiyoriy  $A$  nuqtani  $Oy$  va  $Ox$  o'qlaridan qancha masofalarda yotganini ifodalovchi sonlarning tartiblangan  $(x_0; y_0)$  juftligi  $A$  nuqtaning *koordinatalari* deyiladi va  $A(x_0; y_0)$  tarzida yoziladi (5-rasm). Bunda dastlab nuqtaning absissasi  $x_0$ , so'ngra uning ordinatasi  $y_0$  yoziladi.

**T a' r i f.** *Tekislikdagi ixtiyoriy nuqtaning o'rnini aniq ifodalovchi usul tekislikda koordinatalar sistemasi deyiladi.*

Koordinatalar sistemasi tanlangan tekislik *koordinata tekisligi* deyiladi va  $xOy$  kabi ifodalanadi. Koordinata o'qlari tashkil qilgan to'g'ri burchaklar *koordinata burchaklari (kvadrantlar)* deyiladi va 6-rasmda ko'rsatilgandek belgilanadi.

Koordinatalar o'qlari koordinata tekisligini to'rtta chorakka ajratadi. Ularning har birida nuqta koordinatalarining ishoralarini eslab qolish ma'qul bo'ladi (6-rasm).

Koordinatalar tekisligining har bir  $M$  nuqtasiga  $(x; y)$  sonlar juftligi – uning koordinatalari mos keladi va har bir  $(x; y)$  sonlar juftiga koordinata tekisligining koordinatalari  $(x; y)$  bo'lgan birgina  $M$  nuqtasi mos keladi.

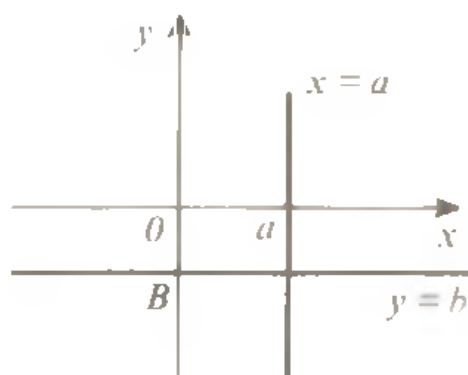

7-rasm

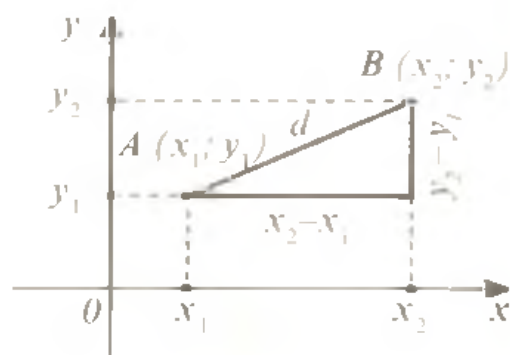

8-rasm

Ushbu zarur holatlarni yodda tutmoqlik darkor:

1) Agar nuqta absissalar o'qida yotsa, u holda uning ordinatasi nolga teng bo'ladi. Ordinatalari nolga teng barcha nuqtalar absissalar o'qi  $Ox$  ga tegishli bo'ladi. Shunga ko'ra  $Ox$  o'qi  $y = 0$  tenglik bilan ifodalanadi.

2) Agar nuqta ordinatalar o'qida yotsa, u holda uning absissasi nolga teng bo'ladi. Absissalari nolga teng bo'lgan barcha nuqtalar ordinatalar o'qi  $Oy$  ga tegishli bo'ladi va shu sababli  $Oy$  o'qi  $x = 0$  tenglik bilan ifodalanadi.

3) Noldan farqli bir xil absissali barcha nuqtalar ordinatalar o'qiga parallel to'g'ri chiziqqa tegishli bo'ladi. Masalan, absissalari

$a$  ( $a$  – haqiqiy son) ga teng bo‘lgan barcha nuqtalar to‘plami  $Oy$  o‘qiga parallel bo‘lgan va undan  $|a|$  masofada o‘tuvchi  $x = a$  to‘g‘ri chiziqqa tegishlidir (7-rasm).

4) Noldan farqli bir xil ordinatali barcha nuqtalar absissalar o‘qiga parallel to‘g‘ri chiziqqa tegishli bo‘ladi. Masalan, ordinatalari  $b$  ( $b$  – biror haqiqiy son) ga teng bo‘lgan barcha nuqtalar to‘plami  $Ox$  o‘qiga parallel bo‘lgan va undan  $|b|$  masofada yotuvchi  $y = b$  to‘g‘ri chiziqqa tegishlidir (7-rasm).

5) Koordinatalar tekisligidagi  $A(x_1; y_1)$  va  $B(x_2; y_2)$  nuqtalar orasidagi masofa

$$|AB| = d = \sqrt{(x_2 - x_1)^2 + (y_2 - y_1)^2}$$

ifoda orqali topiladi (8-rasm).

$A(x_1; y_1)B(x_2; y_2)$  kesma o‘rtasining koordinatalari  $x_0 = \frac{x_1 + x_2}{2}$ ,

$y_0 = \frac{y_1 + y_2}{2}$  tengliklar bilan ifodalanadi.

$AB$  kesmani  $\lambda > 0$  nisbatda bo‘luvchi  $C(x; y)$  nuqta ( $|AC| : |BC| = \lambda$ )

koordinatalari  $x = \frac{x_1 + \lambda x_2}{1 + \lambda}$ ,  $y = \frac{y_1 + \lambda y_2}{1 + \lambda}$  formulalar bilan aniqlanadi.

#### 4-§. Chiziqli funksiya va uning grafigi

**4.1. Funksiya tushunchasi.** Quyidagi masalani qaraylik: yengil avtomobil soatiga 60 km tezlik bilan tekis harakatlanayotgan bo‘lsa, u bosib o‘tadigan masofa vaqtga bog‘liq ravishda ortib boradi. Harakat davomida bosib o‘tiladigan yo‘lni  $S$  harfi bilan, vaqtni  $t$  harfi bilan belgilasak, bu ikki o‘zgaruvchining bog‘liqligi tekis harakat uchun

$$S = 60t$$

tenglik bilan ifodalanadi. Bu tenglik  $S$  yo‘lni  $t$  vaqtning berilgan qiymati bo‘yicha hisoblash qoidasini belgilaydi. Ko‘rilgan masalada  $S$  yo‘l va  $t$  vaqt o‘zgaruvchi miqdorlardir.

Yana bir masalani qaraylik: kvadrat tomonining uzunligi  $x$ , uning yuzi  $y$  bo‘lsa, u holda

$$y = x^2$$

formula kvadrat yuzini tomonning berilgan uzunligi bo‘yicha hisoblash qoidasini beradi. Bu yerda  $y$  – kvadratning yuzi va tomonining uzunligi  $x$  o‘zgaruvchi miqdorlardir.

Qaralgan ikkala masaladan ham ko'rinib turibdiki, o'zgaruvchi miqdorlar orasidagi bog'liqlik biror qoidaga asoslangan bo'lar ekan.

**Ta'rif.** Agar biror sonlar to'plamidan olingan  $x$  ning har bir qiymatiga biror qoida bo'yicha  $y$  son mos qilib qo'yilgan bo'lsa, u holda shu to'plamda funksiya aniqlangan deyiladi va bu bog'lanish odatda

$$y = f(x)$$

shaklida yoziladi.

Bunda  $x$  – erkli o'zgaruvchi yoki argument,  $y$  – erksiz o'zgaruvchi yoki funksiya deyilib,  $f$  belgisi ikki o'zgaruvchi miqdor orasidagi bog'lanish qoidasini anglatadi. Erkli o'zgaruvchini  $x$ , erksiz o'zgaruvchini  $y$ , bog'lanish qoidasini  $f$  bilan belgilash majburiy emas. Funksiyani yozilishida quyidagi kabi belgilashlar ham keng qo'llaniladi:

$$q = f(z); p = \varphi(x); y = g(x); S = S(t)$$

va hokazo. Funksiya tushunchasi VIII bobda kengroq beriladi.

**4.2. Chiziqli funksiya.** **Ta'rif.** Chiziqli funksiya deb,  $y = kx + b$  ko'rinishidagi funksiyaga aytiladi, bu yerda  $k$  va  $b$  – berilgan sonlar.

Bu funksiya haqiqiy sonlar to'plamida aniqlangan.

$b = 0$  bo'lganda chiziqli funksiya  $y = kx$  ko'rinishga ega bo'lib, uning grafigi koordinatalar boshidan o'tuvchi to'g'ri chiziq bo'ladi (9-rasm).

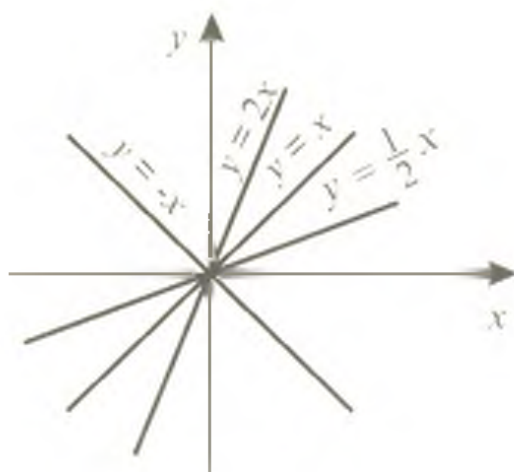

9-rasm



10-rasm

$k$  koeffitsiyent  $y = kx$  to'g'ri chiziq  $Ox$  o'qining musbat yo'nalishi bilan tashkil etadigan burchakni tavsiflaydi va to'g'ri chiziqning burchak koeffitsiyenti deyiladi. Agar  $k > 0$  bo'lsa, bu burchak o't-

kir; agar  $k < 0$  bo'lsa, o'tmas; agar  $k = 0$  bo'lsa, to'g'ri chiziq  $Ox$  o'qi bilan ustma-ust tushadi.

$y = kx + b$  funksiyaning grafigi to'g'ri chiziqdir. Ikki nuqta orqali birgina to'g'ri chiziq o'tkazish mumkin bo'lganligi sababli funksiya grafigiga tegishli ikki nuqtani yasash yetarlidir.  $b$  son funksiya grafigi  $Oy$  o'qini koordinatalar boshidan qanday masofada kesib o'tishini belgilaydi.

**M a s a l a:**  $y = 2x + 3$  funksiya grafigini yasang.

**Y e c h i l i s h i:** funksiya grafigiga tegishli ikkita nuqtaning koordinatalarini aniqlaymiz:

$y(0) = 2 \cdot 0 + 3 = 3$ ;  $(0; 3)$  nuqta funksiya grafigiga tegishli.

$y(-2) = 2 \cdot (-2) + 3 = -1$ ;  $(-2; -1)$  nuqta ham funksiya grafigiga tegishli. Koordinatalar tekisligida bu nuqtalarni belgilaymiz va funksiya grafigini yasaymiz. 10-rasmda  $y = 2x + 3$  va  $y = 2x$  funksiyalar grafigi tasvirlangan.

$y = kx + b$  funksiyaning grafigini  $y = kx$  funksiya grafigini parallel ko'chirish yo'li bilan ham yasash mumkin.

### 5-§. Birinchi darajali ikki noma'lumli tenglamalar sistemasi

Birinchi darajali ikkita noma'lumli ikkita tenglama sistemasining umumiy ko'rinishi quyidagicha yoziladi:

$$\begin{cases} a_1x + b_1y = c_1, \\ a_2x + b_2y = c_2. \end{cases}$$

Bunda  $a_1, b_1, a_2, b_2, c_1, c_2$  haqiqiy sonlar bo'lib,  $a_1, b_1, a_2, b_2$  sistema koeffitsiyentlari,  $c_1, c_2$  ozod hadlar deyiladi;  $x, y$  — noma'lumlar.

Agar  $c_1$  va  $c_2$  ozod hadlarning ikkalasi nolga teng bo'lsa, sistema bir jinsli deyiladi, hech bo'lmaganda bittasi noldan farqli bo'lsa, bir jinslimas deyiladi.

**5.1. Tenglamalar sistemasining yechimi** deb shunday  $(x_0; y_0)$  sonlar juftiga aytiladiki, ularni sistemadagi noma'lumlar o'rniga qo'yilsa, to'g'ri sonli tengliklar hosil bo'ladi.

**5.2. Tenglamalar sistemasini yechish** — bu uning barcha yechimini topish yoki ularning mavjud emasligini aniqlash demakdir.

**5.3. Agar tenglamalar sistemasi** hech bo'lmaganda bitta yechimga ega bo'lsa, bunday sistema *birgalikdagi sistema* deyiladi. Agar u

birorta ham yechimga ega bo'lmasa, *birgalikda bo'lmagan sistema* deyiladi.

5.4. Agar ikkita tenglama sistemasidan birining yechimlari to'plami ikkinchisining ham yechimlari to'plami bo'lsa, u holda bunday sistemalar *teng kuchli sistema* deyiladi.

5.5. Ikki noma'lumli tenglamalar sistemasini grafik usulda yechish har ikkala tenglama grafiklarining umumiy nuqtalarining koordinatalarini topish demakdir.

5.6. Ma'lumki, to'g'ri chiziqlar tekislikda biror nuqtada kesi-shishi, yoki ular parallel bo'lishi, yoki ustma-ust tushishi mumkin. Shunga ko'ra ikki noma'lumli chiziqli tenglamalar sistemasi:

- a) yagona yechimga ega bo'ladi;
- b) yechimga ega bo'lmaydi;
- d) cheksiz ko'p yechimga ega bo'ladi.

5.7. Ikki noma'lumli chiziqli tenglamalar sistemasini yechmas-dan, ular yagona yechimga egami-yo'qmi yoki cheksiz ko'p yechimga egami, degan savolga javob berish mumkin.

1) Agar  $\frac{a_1}{a_2} \neq \frac{b_1}{b_2}$  bo'lsa, ya'ni  $x$  va  $y$  noma'lumlarning koef-fitsiyentlari proporsional bo'lmasa, u holda sistema yagona yechimga ega. Bu yechim ikki to'g'ri chiziqning kesishish nuqtasining koordinatalaridir (11-rasm).

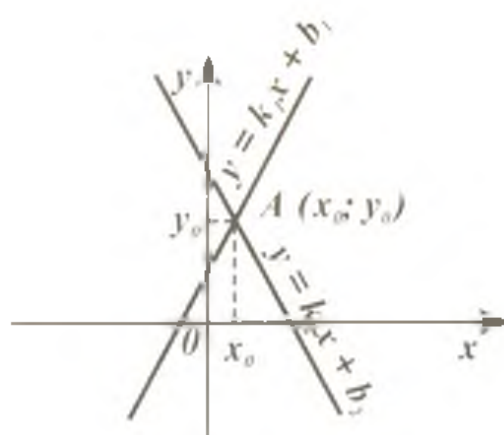

11-rasm

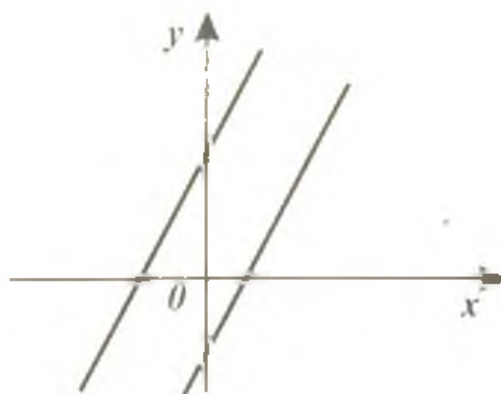

12-rasm

2) Agar  $\frac{a_1}{a_2} = \frac{b_1}{b_2} \neq \frac{c_1}{c_2}$  bo'lsa, sistema yechimga ega emas. Bu holda tenglamalar grafiklari bo'lgan to'g'ri chiziqlar parallel bo'lib, ustma-ust tushmaydi. (12-rasm).

3) Agar  $\frac{a_1}{a_2} = \frac{b_1}{b_2} = \frac{c_1}{c_2}$  bo'lsa, ( $x$  va  $y$  noma'lumlarning koefitsiyentlari proporsional), tenglamalar sistemasini cheksiz ko'p yechimga ega. Bu holda to'g'ri chiziqlar ustma-ust tushadi.

**5.8. Ikki noma'lumli chiziqli tenglamalar sistemasini o'rniga qo'yish usuli bilan yechish.** Bu usulga ko'ra tenglamani yechish quyidagicha amalga oshiriladi:

1) sistemaning bir tenglamasidan (qaysinisidan bo'lishining farqi yo'q) bir noma'lumni ikkinchisi orqali, masalan,  $y$  ni  $x$  orqali ifodalanadi;

2)  $y$  ning  $x$  orqali ifodasini sistemaning ikkinchi tenglamasiga qo'yib,  $x$  ga nisbatan bir noma'lumli tenglama hosil qilinadi;

3) hosil bo'lgan bir noma'lumli tenglamani yechib,  $x$  ning  $x_0$  qiymati topiladi;

4)  $x$  ning topilgan qiymatini  $y$  ning  $x$  orqali ifodasiga qo'yib,  $y$  ga nisbatan bir noma'lumli tenglama hosil qilinadi;

5) hosil bo'lgan bir noma'lumli tenglamani yechib,  $y$  ning  $y_0$  qiymati topiladi;

6) berilgan ikki noma'lumli tenglamalar sistemasining yechimi bitta sonlar jufti  $(x_0; y_0)$  shaklida yoziladi.

1-m i s o l. 
$$\begin{cases} x + y = 13, \\ 2x - y = 12,5 \end{cases}$$
 tenglamalar sistemasini yeching.

Yechilishi:

$$\begin{cases} x + y = 13, \\ 2x - y = 12,5 \end{cases} \Leftrightarrow \begin{cases} y = 13 - x \quad (*) \\ 2x - (13 - x) = 12,5 \end{cases} \Rightarrow 2x - 13 + x = 12,5 \\ \Leftrightarrow 3x = 25,5 \Rightarrow x = 8,5.$$

Topilgan  $x$  ning qiymatini (\*) ga qo'yib,  $y$  ning qiymatini topamiz:  $y = 13 - 8,5 = 4,5$ .

J a v o b:  $(8,5; 4,5)$ .

2-m i s o l. Tenglamalar sistemasini o'rniga qo'yish usuli bilan yeching:

$$\begin{cases} 7x + 9y = 8, \\ 9x - 8y = 69. \end{cases}$$

Yechilishi: 
$$\begin{cases} 7x + 9y = 8 \\ 9x - 8y = 69 \end{cases} \Leftrightarrow \begin{cases} x = \frac{8-9y}{7} \quad (*) \\ 9 \cdot \frac{8-9y}{7} - 8y = 69 \end{cases} \Leftrightarrow$$

$$\Leftrightarrow \frac{72-81y}{7} - 8y = 69 \Leftrightarrow 72 - 81y - 56y = 483 \Rightarrow -137y = 411 \Rightarrow [y = -3.$$

Topilgan  $y$  ni (\*) ga qo'yib,  $x$  ning qiymatini topamiz:

$$x = \frac{8-9(-3)}{7} = \frac{8+27}{7} = 5.$$

J a v o b: (5; -3).

**5.9. Chiziqli tenglamalar sistemasini algebraik qo'shish (noma'lumlardan birini yo'qotish) usuli bilan yechish.** Bu usulga ko'ra sistemani yechish quyidagicha amalga oshiriladi:

1) tenglamalar sistemasidagi har ikki tenglamada noma'lumlardan birining koeffitsiyentlari modullari tenglashtiriladi;

2) hosil bo'lgan tenglamalarni hadlab qo'shib yoki ayirib, bitta noma'lum topiladi;

3) topilgan noma'lum qiymatini berilgan tenglamalardan biriga qo'yilib, ikkinchi noma'lum ham topiladi.

3-m i s o l.  $\begin{cases} 2x + y = 8, \\ 3x + 4y = 7 \end{cases}$  tenglamalar sistemasini yeching.

Y e c h i l i s h i:

$$\begin{cases} 2x + y = 8, [\cdot(4)] \\ 3x + 4y = 7 \end{cases} \Leftrightarrow \begin{cases} 8x + 4y = 32 \\ 3x + 4y = 7 \end{cases} \quad [\downarrow (-)] \Rightarrow 5x = 25 \Rightarrow [x = 5.$$

(Bu yerda  $[\cdot(4)]$  belgi birinchi tenglamaning har ikkala tomoni 4 ga ko'paytirilganini,  $[\downarrow (-)]$  belgi sistemaning birinchi tenglamasidan ikkinchi tenglamasi ayirilayotganini anglatadi).  $x$  ning topilgan qiymatini berilgan sistemaning birinchi tenglamasiga qo'yib, ikkinchi noma'lum  $y$  ni topamiz:

$$2 \cdot 5 + y = 8 \Leftrightarrow y = 8 - 10 \Rightarrow [y = -2.$$

J a v o b: (5; -2).

4-m i s o l.  $\begin{cases} 2x - 3y = 8, \\ 7x - 5y = -5. \end{cases}$   $x, y$  ko'paytmani toping.

Y e c h i l i s h i:

$$\begin{cases} 2x - 3y = 8, [\cdot(5)] \\ 7x - 5y = -5, [ \cdot(-3) ] \end{cases} \Rightarrow \begin{cases} 10x - 15y = 40, \\ -21x + 15y = 15 \end{cases} \oplus \Rightarrow -11x = 55 \Rightarrow$$

$$\Rightarrow [x = -5.$$

Topilgan  $x$  ning qiymatini berilgan sistemaning birinchi tenglamasiga qo'yib, noma'lum  $y$  ning qiymatini topamiz:

$$2 \cdot (-5) - 3y = 8 \Leftrightarrow -10 - 3y = 8 \Leftrightarrow 3y = -18 \Rightarrow y = -6.$$

Endi so'ralgan  $xy$  ko'paytma qiymatini topamiz:

$$xy = (-5) \cdot (-6) = 30.$$

J a v o b: 30.

### 5.10. Chiziqli tenglamalar sistemasini grafik usul bilan yechish.

Tenglamalar sistemasini yechishning grafik usuli quyidagi ketma-ketlikda bajariladi:

1) sistemaning har bir tenglamasida noma'lum  $y$  ni noma'lum  $x$  orqali  $y = kx + b$  shaklda ifodalab, tenglamalar grafiklari yasaladi;

2) yasalgan to'g'ri chiziqlar kesishish nuqtasining (agar ular kesishsa) koordinatalari (11-rasmga qarang) topiladi. Bu  $(x_0; y_0)$  koordinatalar berilgan tenglamalar sistemasining yechimi bo'ladi.

5-m i s o l. Tenglamalar sistemasini grafik usul bilan yeching:

$$\begin{cases} x + 3y = 6, \\ 2x + y = 7. \end{cases}$$

Y e c h i l i s h i: Tenglamalar sistemasining har bir tenglamasida  $y$  ni  $x$  orqali ifodalaymiz:

$$\begin{cases} x + 3y = 6, \\ 2x + y = 7. \end{cases} \Rightarrow \begin{cases} y = -\frac{1}{3}x + 2, \\ y = -2x + 7. \end{cases}$$

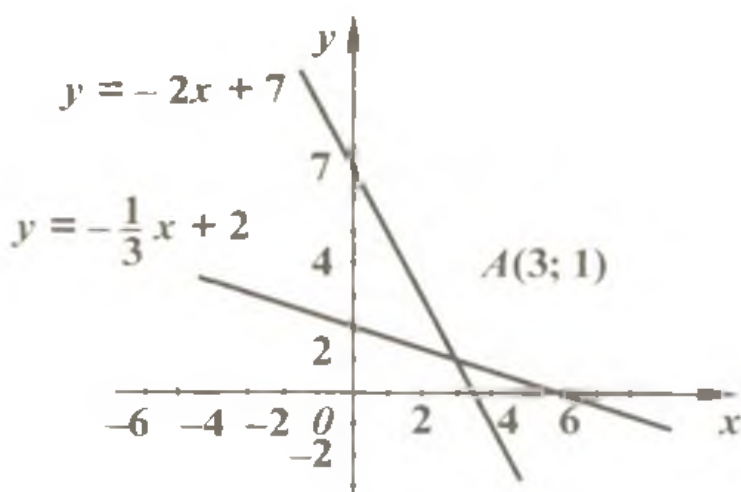

13-rasm



Tenglamalarning grafiklarini yasaymiz (13-rasm).

Yasalgan ikki to'g'ri chiziq  $A(3;1)$  nuqtada kesishadi. Bu nuqtaning absissasi  $x_0 = 3$ , ordinatasi  $y_0 = 1$ . Bu nuqta ikkala to'g'ri chiziqqa ham tegishli bo'lib, uning koordinatalari sistemaning ikkala tenglamasini to'g'ri tenglikka aylantiradi.

J a v o b: (3; 1).

6-m i s o l. Tenglamalar sistemasini yeching:

$$\begin{cases} 3(x - y) = 6(y + 1), \\ \frac{x}{3} - 1\frac{1}{3} = y. \end{cases}$$

Y e c h i l i s h i:

$$\begin{cases} 3(x - y) = 6(y + 1), \\ \frac{x}{3} - 1\frac{1}{3} = y \end{cases} \Leftrightarrow \begin{cases} 3x - 3y = 6y + 6, \\ \frac{x}{3} - \frac{4}{3} = y \end{cases} \Leftrightarrow \begin{cases} 3x - 9y = 6, [ : 3 ] \\ x - 3y = 4 \end{cases}$$

$$\Leftrightarrow \begin{cases} x - 3y = 2, \\ x - 3y = 4. \end{cases}$$

Shakl almashtirishlar natijasida hosil bo'lgan bu tenglamalar sistemasida

$$a_1 = 1; b_1 = -3; c_1 = 2; a_2 = 1; b_2 = -3; c_2 = 4; \frac{a_1}{a_2} = 1;$$

$$\frac{b_1}{b_2} = 1; \frac{c_1}{c_2} = \frac{1}{2}.$$

Demak, 5.7-band (2) ga ko'ra sistema yechimga ega emas.

J a v o b: Yechimga ega emas.

7-m i s o l. Tenglamalar sistemasini yeching:

$$\begin{cases} 2x + 3y = 13, \\ y = \frac{13 - 2x}{3}. \end{cases}$$

Y e c h i l i s h i:

$$\begin{cases} 2x + 3y = 13, \\ y = \frac{13 - 2x}{3} \end{cases} \Leftrightarrow \begin{cases} 2x + 3y = 13, \\ 3y = 13 - 2x \end{cases} \Leftrightarrow \begin{cases} 2x + 3y = 13, \\ 2x + 3y = 13. \end{cases}$$

Bu tenglamalar sistemasida ko'rinib turibdiki, noma'lumlar koeffitsiyentlari va ozod hadlar proporsional. Demak, sistema 5.7-band (3) ga ko'ra cheksiz ko'p yechimga ega.

J a v o b: yechim cheksiz ko'p.

## 6-§. Ikkinchi tartibli determinantlar

**6.1. Ikkinchi tartibli determinant tushunchasi.** Matematikada algebraik amallarni yozishning yana bir shakli muhim o'rin egallaydi. Yozuvning bu ko'rinishi quyidagi shaklga ega:

$$\begin{vmatrix} a_1 & b_1 \\ a_2 & b_2 \end{vmatrix}$$

Ikki satr va ikki ustunga ega bo'lgan bu jadval shaklidagi yozuv  $a_1b_2 - b_1a_2$  ayirmaning hisoblash uchun ishlatiladi va *ikkinchi tartibli determinant* deyiladi. Shunday qilib,

$$\begin{vmatrix} a_1 & b_1 \\ a_2 & b_2 \end{vmatrix} = a_1 \cdot b_2 - b_1 \cdot a_2.$$

Bunda  $a_1, a_2, b_1, b_2$  sonlar determinantning *elementlari* deyiladi.

1-m i s o l.  $\begin{vmatrix} 2 & -3 \\ -5 & -4 \end{vmatrix}$  determinantning qiymatini hisoblang.

Yechilishi.  $\begin{vmatrix} 2 & -3 \\ -5 & -4 \end{vmatrix} = 2 \cdot (-4) - (-3) \cdot (-5) = -8 - 15 = -23.$

J a v o b: -23.

Agar determinantning satrlaridagi elementlari proporsional, ya'ni

$$a_1 = ka_2; b_1 = kb_2$$

( $k$  – proporsionallik koeffitsiyenti) bo'lsa, determinantning qiymati nolga teng bo'ladi:

$$\begin{vmatrix} a_1 & b_1 \\ a_2 & b_2 \end{vmatrix} = \begin{vmatrix} ka_2 & kb_2 \\ a_2 & b_2 \end{vmatrix} = ka_2b_2 - ka_2b_2 = 0.$$

**6.2. Ikkinchi tartibli determinantni chiziqli tenglamalar sistemasini yechishdagi tathqiqi.** Ushbu

$$\begin{cases} a_1x + b_1y = c_1, \\ a_2x + b_2y = c_2 \end{cases} \quad (1)$$

tenglamalar sistemasining *asosiy determinanti* deb  $x$  va  $y$  nomalumlari oldidagi koeffitsiyentlardan tuzilgan

$$\begin{vmatrix} a_1 & b_1 \\ a_2 & b_2 \end{vmatrix}$$

determinantga aytiladi. Bu determinant yunoncha  $\Delta$  («delta») harfi bilan belgilanadi:

$$\Delta = \begin{vmatrix} a_1 & b_1 \\ a_2 & b_2 \end{vmatrix} = a_1 b_2 - b_1 a_2. \quad (2)$$

(1) tenglamalar sistemasining *birinchi yordamchi determinanti* deb,

$$\Delta_x = \begin{vmatrix} c_1 & b_1 \\ c_2 & b_2 \end{vmatrix} = c_1 b_2 - b_1 c_2 \quad (3)$$

determinantga, *ikkinchi yordamchi determinanti* deb,

$$\Delta_y = \begin{vmatrix} a_1 & c_1 \\ a_2 & c_2 \end{vmatrix} = a_1 c_2 - c_1 a_2 \quad (4)$$

determinantga aytiladi.

Ikki noma'lumli chizikli tenglamalar sistemasini yechishning **Kramer qoidasi** deb nomlangan yana bir usuli ushbu teoremaга asoslanadi:

**Teorema.** *Agar (1) tenglamalar sistemasining asosiy determinanti nolga teng bo'lmasa, u holda bu tenglamalar sistemasi birgalikda bo'ladi va birdan-bir yechimga ega bo'ladi.*

Kramer qoidasiga ko'ra

$$x = \frac{\Delta_x}{\Delta}; y = \frac{\Delta_y}{\Delta}.$$

2-misol. Sistemani Kramer qoidasidan foydalanib yeching:

$$\begin{cases} \frac{1}{6}x - \frac{1}{3}y = 6, \\ x - y = 0. \end{cases}$$

$$\text{Yechilishi: } \Delta = \begin{vmatrix} \frac{1}{6} & -\frac{1}{3} \\ 1 & -1 \end{vmatrix} = -\frac{1}{6} + \frac{1}{3} = \frac{1}{6}; \quad \Delta_x = \begin{vmatrix} 6 & -\frac{1}{3} \\ 0 & -1 \end{vmatrix} =$$

$$= -6 - \left(-\frac{1}{3}\right) \cdot 0 = -6; \quad \Delta_y = \begin{vmatrix} \frac{1}{6} & 6 \\ 1 & 0 \end{vmatrix} = \frac{1}{6} \cdot 0 - 6 \cdot 1 = -6;$$

$$x = \frac{\Delta_x}{\Delta} = \frac{-6}{\frac{1}{6}} = -36; y = -\frac{6}{\frac{1}{6}} = -36.$$

Javob: (-36; -36).

Chizikli tenglamalar sistemasini yechimlarini tahlil qilishda ushbu teoremalardan foydalaniladi.

**Teorema.** Agar (1) sistemaning asosiy determinanti nolga teng bo'lib, yordamchi determinantlar (3) yoki (4) dan bittasi bo'lsa ham nolga teng bo'lmasa, sistema birgalikda bo'lmaydi.

**Teorema.** Agar (1) tenglamalar sistemasining asosiy determinanti va (3), (4) yordamchi determinantlari nolga teng bo'lsa va noma'lumlar oldidagi koeffitsiyentlar orasida kamida bittasi noldan farqli bo'lsa, sistema cheksiz ko'p yechimga ega bo'ladi.

3-misol. Tenglamalar sistemasini yeching.

$$\begin{cases} 2x - 1,5y = 3, \\ 3y - 4x = -6. \end{cases}$$

Yechilishi:  $\begin{cases} 2x - 1,5y = 3, \\ 3y - 4x = -6 \end{cases} \Leftrightarrow \begin{cases} 2x - 1,5y = 3, \\ -4x + 3y = -6. \end{cases}$

Sistemaning asosiy va yordamchi determinantlarining qiymatini hisoblaymiz:

$$\Delta = \begin{vmatrix} 2 & -1,5 \\ -4 & 3 \end{vmatrix} = 6 - 6 = 0,$$

$$\Delta_x = \begin{vmatrix} 3 & -1,5 \\ -6 & 3 \end{vmatrix} = 9 - 9 = 0, \quad \Delta_y = \begin{vmatrix} 2 & 3 \\ -4 & -6 \end{vmatrix} = -12 + 12 = 0.$$

Demak, sistema cheksiz ko'p yechimga ega.

Javob: cheksiz ko'p yechimga ega.

### 7-§. Parametrli chiziqli tenglamalar, tenglamalar sistemasi

Parametrli tenglamalar matematikaning muhim bo'limlaridan hisoblanadi. Hatto eng sodda bir noma'lumli tenglamalar ham, o'zlariga mos parametrik tenglamalarning xususiy holidir.

$$f(a, b, c, \dots, k, x) = \varphi(a, b, c, \dots, k, x)$$

shaklidagi tenglama berilgan bo'lsin, bu yerda  $a, b, c, \dots, k, x$  — o'zgaruvchi miqdorlar. Bunday tenglamalarni yechishda *parametr* deb ataluvchi  $a, b, c, \dots, k$  o'zgaruvchilar o'zgarmas miqdorlar deb qaraladi, tenglamaning o'zi esa *parametrli tenglama* deb ataladi. Odatda parametrli tenglamalarda parametrlar lotin alfavitining dastlabki harflari  $a, b, c, \dots$  lar bilan, noma'lumlar esa so'nggi  $x, y, z, \dots$  harflari bilan belgilanadi.

Parametrli tenglama yechimining mavjudligi tenglamada qatnashayotgan parametrlarga bog'liq bo'lib, bunday tenglamalarni yechish —

bu parametrlarning qanday qiymatlarida tenglama yechimga ega, qanday qiymatlarida yechimga ega emasligini aniqlash demakdir.

Masalan, noma'lum  $x$  ga nisbatan chiziqli bo'lgan  $ax - b = 0$  tenglamani qaraylik, bu yerda  $a$  va  $b$  - parametrlar. Bu tenglama  $ax = b$  tenglamaga teng kuchli bo'lib,  $a \neq 0$  da yagona  $x = \frac{b}{a}$  yechimga ega; agar  $a = b = 0$  bo'lsa, tenglama cheksiz ko'p yechimga ega. Agar  $a = 0$ ;  $b \neq 0$  bo'lsa, tenglama yechimga ega emas.

Chiziqli ikki noma'lumli ikkita tenglama sistemasi

$$\begin{cases} a_1x + b_1x = c_1, \\ a_2x + b_2x = c_2 \end{cases}$$

ning koeffitsiyentlari  $a_1, b_1, a_2, b_2$  va ozod hadlari  $c_1, c_2$  ham parametrlardir. Ular qanday munosabatda bo'lganlarida sistema yagona yechimga, cheksiz ko'p yechimga ega bo'lishi yoki yechimga ega emasligi IV bob, 5-§, 5.7- bandeda keltirilgan.

Misollar. Parametrlil tenglamalarni yeching.

1)  $ax = a$ .

Yechilishi. Agar  $a = 0$  bo'lsa,  $0 \cdot x = 0$  bo'lib, tenglama cheksiz ko'p yechimga ega. Agar  $a \neq 0$  bo'lsa,  $x = \frac{a}{a} = 1$  yagona yechimga ega.

2)  $x + 2 = ax$ .

Yechilishi.  $x + 2 = ax \Rightarrow x - ax = -2 \Rightarrow x(a - 1) = 2 \Rightarrow$

agar  $a = 1$  bo'lsa, tenglama yechimga ega emas;  
 agar  $a \neq 1$  bo'lsa, tenglama  $x = \frac{2}{a-1}$  yagona ildizga ega.

3)  $(a^2 - 1)x = 2a^2 + a - 3$ .

Yechilishi. Berilgan tenglama noma'lum  $x$  ga nisbatan chiziqlidir.

$(a^2 - 1)x = 2a^2 + a - 3 \Leftrightarrow (a - 1)(a + 1)x = (2a + 3)(a - 1) \Rightarrow$

agar  $a = 1$  bo'lsa,  $0 \cdot x = 0$  - tenglama cheksiz ko'p yechimga ega;  
 agar  $a = -1$  bo'lsa,  $0 \cdot x = -2$  - tenglama yechimga ega emas;  
 agar  $a \neq \pm 1$  bo'lsa,  $x = \frac{2a+3}{a+1}$  - tenglama yagona ildizga ega.

4)  $4 + ax = 3x + 1$  tenglama  $a$  ning qanday qiymatlarida yechimga ega emas?

Yechilishi.  $4 + ax = 3x + 1 \Leftrightarrow 3x - ax = 3 \Leftrightarrow (3 - a)x = 3 \Leftrightarrow$

agar  $a = 3$  bo'lsa,  $0 \cdot x = 3$  - tenglama yechimga ega emas;  
 agar  $a \neq 3$  bo'lsa,  $x = \frac{3}{3-a}$  - tenglama yagona ildizga ega.

Javob: 3.

5) Tenglamalar sistemasi  $k$  ning qanday qiymatida yechimga ega emasligini aniqlang:

$$\begin{cases} kx - y = 3, \\ -x + ky = -3. \end{cases}$$

**Yechilishi.** Ma'lumki, birinchi darajali ikki noma'lumli tenglamalar sistemasida koeffitsiyentlar proporsional bo'lib, ozod hadlar proporsional bo'lmasa, sistema yechimga ega bo'lmaydi:

$$\frac{k}{-1} = \frac{-1}{k} \neq -\frac{3}{3},$$

bundan

$$k^2 = 1 \Rightarrow (k-1)(k+1) = 0 \Rightarrow \begin{cases} k_1 = -1, \\ k_2 = 1. \end{cases}$$

$k = 1$  da sistema cheksiz ko'p yechimga ega,  $k = -1$  da sistema yechimga ega emas.

**Javob:**  $-1$ .

6)  $n$  ning qanday qiymatida

$$\begin{cases} (6+n)x - 6y = 2, \\ -2nx + 3y = n-3 \end{cases}$$

tenglamalar sistemasi cheksiz ko'p yechimga ega bo'ladi?

**Yechilishi.** Chiziqli ikki noma'lumli tenglamalar sistema-sining IV bob, 5-§, 5.7- badda keltirilgan cheksiz ko'p yechimga ega bo'lish shartidan foydalanamiz:

$$\frac{6+n}{-2n} = \frac{-6}{3} = \frac{2}{n-3}.$$

$$\text{Bundan } 18 + 3n = 12n \Leftrightarrow 9n = 18 \Rightarrow n = 2.$$

**Javob:** 2.

$$7) \begin{cases} \frac{2x+5y}{y} = 31, \\ \frac{x-2y}{y} = 11 \end{cases} \text{ sistema nechta yechimga ega?}$$

**Yechilishi:**

$$\begin{aligned} & \begin{cases} \frac{2x+5y}{y} = 31, \\ \frac{x-2y}{y} = 11 \end{cases} \Leftrightarrow \begin{cases} 2x+5y = 31y, \\ x-2y = 11y \end{cases} \Leftrightarrow \begin{cases} 2x-26y = 0, \\ x-13y = 0 \end{cases} \Leftrightarrow \\ & \Leftrightarrow \begin{cases} x-13y = 0, \\ x-13y = 0. \end{cases} \end{aligned}$$

Demak, amalda biz bitta ikki noma'lumli bir jinsli tenglamaga egamiz. U cheksiz ko'p yechimga ega.

J a v o b: cheksiz ko'p yechimga ega.

## 8-§. Sonli tengsizliklar

**8.1. Tengsizlik tushunchasi.** Ikki haqiqiy son  $a$  va  $b$  taqqoslanayotganda quyidagi hollar bo'lishi mumkin:

1)  $a = b$  ( $a$  son  $b$  songa teng); 2)  $a > b$  ( $a$  son  $b$  sonidan katta);  
3)  $a < b$  ( $a$  son  $b$  sonidan kichik). Odatda ikki miqdor taqqoslanayotganda ularning ayirmasi qaraladi. Agar  $a - b$  ayirma musbat bo'lsa,  $a$  miqdor  $b$  miqdordan katta; agar  $a - b$  ayirma nolga teng bo'lsa,  $a$  va  $b$  miqdorlar teng; agar  $a - b$  ayirma manfiy bo'lsa,  $a$  miqdor  $b$  miqdordan kichik bo'ladi.

**8.2.**  $a \geq b$  ( $a \leq b$ ) yozuv  $a > b$  yoki  $a = b$  ekanligini anglatib, « $a$  son  $b$  dan katta yoki teng» (« $a$  son  $b$  dan kichik yoki teng») deb o'qiladi.

T a ` r i f. Ikki son yoki o'zgaruvchi qatnashgan ikki ifoda  $>$ ,  $<$ ,  $\geq$  yoki  $\leq$  belgilari bilan birlashtirilgan yozuv tengsizlik deb ataladi. Agar tengsizlik  $>$  yoki  $<$  belgilari yordamida tuzilgan bo'lsa, u qat'iy tengsizlik,  $\geq$  yoki  $\leq$  belgilari yordamida tuzilgan bo'lsa, noqat'iy tengsizlik deyiladi.

**8.3.** Agar tengsizlik haqiqiy (rost) fikrni anglatsa, u to'g'ri tengsizlik deyiladi.

**8.4.** Ikki  $a < b$ ,  $b < c$  tengsizlik o'rniga  $a < b < c$  shaklidagi tengsizlik ishlatiladi. Bunday tengsizlik qo'sh tengsizlik deyiladi.

**8.5.** Tengsizlik faqat sonlardan tuzilgan bo'lsa, u sonli tengsizlik deyiladi.

**8.6.** Agar tengsizlikda harfli ifodalar ham ishtirok etsa, u o'zgaruvchining ma'lum, tayinli qiymatlaridagina to'g'ri tengsizlik bo'ladi.

Masalan,  $(a + b)^2 \geq 0$  tengsizlik  $a$  va  $b$  ning har qanday haqiqiy qiymatlarida o'rinlidir, chunki har qanday sonning kvadrati manfiy

emas;  $(x - \frac{1}{2})^2 > 0$  tengsizlik o'zgaruvchi  $x$  ning  $\frac{1}{2}$  dan boshqa barcha qiymatlarida to'g'ri.

### 8.7. Tengsizliklarning asosiy xossalari.

1. Agar  $a > b$  bo'lsa,  $b < a$  va aksincha,  $a < b$  bo'lsa,  $b > a$  bo'ladi.

2. Agar  $a > b$ ,  $b > c$  bo'lsa,  $a > c$  bo'ladi.

Bu xossaning geometrik talqini quyidagidan iborat:  $a$  songa mos keluvchi  $A$  nuqta  $b$  songa mos keluvchi  $B$  nuqtadan o'ngda yotsin,  $B$  nuqta esa o'z navbatida  $c$  songa mos keluvchi  $C$  nuqtadan o'ngda yotadi (14-rasm).

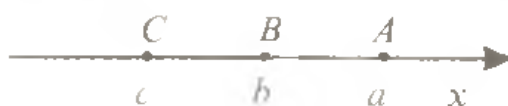

14-rasm

3. Agar sonli tengsizlikning ikkala qismiga bir xil son qo'shilsa yoki ikkala qismidan bir xil son ayrilsa tengsizlik belgisi saqlanadi, ya'ni  $a > b$  bo'lsa, ixtiyoriy  $c$  son uchun  $a + c > b + c$  yoki  $a - c > b - c$  bo'ladi.

4. Sonli tengsizlikning bir qismidagi istalgan qo'shiluvchini, uning ishorasini qarama-qarshisiga almashtirib, ikkinchi qismiga o'tkazish mumkin, ya'ni  $a + b > c$  bo'lsa,  $a - c > -b$  bo'ladi.

5.  $a > b$  bo'lsin. Agar  $c > 0$  bo'lsa,  $ac > bc$  bo'ladi, agar  $c < 0$  bo'lsa,  $ac < bc$  bo'ladi.

6. Tengsizlikni musbat songa hadma-had bo'lganda tengsizlik ishorasi saqlanadi, manfiy songa hadma-had bo'lganda esa tengsizlik ishorasi qarama-qarshisiga almashinadi. Masalan, agar  $a > b$  bo'lsa, u holda  $\frac{1}{3}a > \frac{1}{3}b$ ;  $-\frac{1}{5}a < -\frac{1}{5}b$  bo'ladi.

7. Bir xil ma'noli tengsizliklarni hadma-had qo'shish mumkin, ya'ni  $a > b$  va  $c > d$  bo'lsa,  $a + c > b + d$  bo'ladi.

8. Ikkita qarama-qarshi ma'noli tengsizliklarni hadma-had ayirish mumkin; natijada kamayuvchi tengsizlikning ishorasi qoldiriladi, ya'ni  $a > b$  va  $c < d$  bo'lsa,  $a - c > b - d$  bo'ladi.

Masalan,

$$1) \begin{cases} 2 > 0 \\ -3 < 6 \end{cases} \ominus$$

$$5 > -6$$

$$2) \begin{cases} 10 < 15 \\ 3 > 2 \end{cases} \ominus$$

$$7 < 13$$



**Eslatma:** bir xil ma'noli tengsizliklarni hadma-had ayirish, umuman aytganda, mumkin emas.

**9. Qismlari musbat bo'lgan bir xil ma'noli tengsizliklarni hadma-had ko'paytirish mumkin:**  $a > b$  va  $c > d$  ( $a > 0, b > 0, c > 0, d > 0$ ) bo'lsa,  $ac > bd$ .

**10.  $a > b$  ( $a > 0, b > 0$ ) bo'lsa, har qanday  $n \in \mathbb{N}$  uchun  $a^n > b^n$  bo'ladi.**

**8.8. Tarkibida noma'lum qatnashgan tengsizliklar.** *Tarkibidagi harflarning hamma qiymatlarida emas, balki ba'zi qiymatlarida bajariladigan (yoki hech bir qiymatida ham bajarilmaydigan) noma'lum miqdor qatnashgan tengsizlikni yechish – noma'lum miqdorning shu tengsizlikni qanoatlantiradigan barcha qiymatlarni topish demakdir.*

Tenglamalarni yechishga o'xshash, tengsizliklarni yechishda ham berilgan tengsizlik o'ziga teng kuchli (ekvivalent) tengsizlikka keltiriladi.

**Ta'rif.** *Agar bir xil noma'lum miqdorga ega bo'lgan ikki tengsizlik shu tengsizlikning bir xil qiymatlarida bajarilsa, bunday tengsizliklar teng kuchli yoki ekvivalent tengsizliklar deyiladi. Shuningdek, noma'lum miqdorning hech bir qiymatlarida bajarilmaydigan tengsizliklar ham teng kuchli hisoblanadi.*

**Misolalar:**

1)  $2x > 0$  va  $-2x < 0$  – ekvivalent tengsizliklar;

2)  $x^2 < -1$  va  $-(5x^2 + 3) > 0$  – ekvivalent tengsizliklar;

3)  $x > 0$  va  $x^2 > 0$  – ekvivalent bo'lmagan tengsizliklar.

Noma'lum miqdor qatnashgan tengsizliklarni yechishda ekvivalent tengsizliklarni ushbu xossalardan foydalaniladi:

**1. Tengsizlikning ikkala qismiga noma'lum miqdorning qabul qilishi mumkin bo'lgan barcha qiymatlari uchun aniqlangan son yoki ifoda qo'shilsa yoki ikkala qismidan ayirilsa, berilgan tengsizlikka ekvivalent tengsizlik hosil bo'ladi.**

**2. Noma'lum miqdorning qabul qilishi mumkin bo'lgan barcha qiymatlari uchun aniqlangan ixtiyoriy qo'shiluvchining ishorasini qarama-qarshisiga almashtirib, tengsizlikning bir qismidan ikkinchi qismiga o'tkazish mumkin.**

**Misol:**  $3x + 1 < 2 - x \Leftrightarrow 3x + x < 2 - 1 \Rightarrow 4x < 1 \Rightarrow \left[ x < \frac{1}{4} \right]$ .

**3. Agar tengsizlikning ikkala qismi musbat songa yoki faqat musbat qiymatlarni qabul qiluvchi va noma'lum miqdorning qabul qilishi**

*mumkin bo'lgan barcha qiymatlari uchun aniqlangan ifodaga ko'paytirilsa, berilgan tengsizlikka ekvivalent tengsizlik hosil bo'ladi.*

4. Agar tengsizlikning ikkala qismi manfiy songa yoki noma'lum miqdorning qabul qilishi mumkin bo'lgan barcha qiymatlari uchun aniqlangan va faqat manfiy qiymatlar qabul qiladigan ifodaga ko'paytirilsa, u holda tengsizlik ishorasini qarama-qarshisiga ( $>$  ni  $<$  ga,  $<$  ni  $>$  ga) almashtirish natijasida berilgan tengsizlikka ekvivalent tengsizlik hosil bo'ladi.

## 9-§. Chiziqli tengsizliklar

**9.1. Chiziqli tengsizlik tushunchasi.** T a' r i f. Chap va o'ng qismlari noma'lum miqdorga nisbatan chiziqli funksiyalardan iborat bo'lgan tengsizliklar chiziqli tengsizliklar deb ataladi.

Masalan,  $2x - 1 \geq -x + 3$ ,  $5 > 6 - 6x$ ,  $3x < 0$ ,  $8 - 2x < x - 1$  kabi tengsizliklar chiziqli tengsizliklardir.

Umuman, chiziqli tengsizlik

$$ax + b > cx + d \quad (ax + b < cx + d)$$

shaklida yoziladi. Agar  $a \neq c$  bo'lsa, bunday tengsizlik *birinchi darajali tengsizlik* deyiladi. Har qanday birinchi darajali tengsizlik chiziqli tengsizlikdir. Teskari tasdiq to'g'ri emas. Masalan,  $0 \cdot x > -2$  tengsizlik chiziqlidir, ammo birinchi darajali emas.

Istalgan chiziqli tengsizlik ushbu

$$mx > n \quad (mx < n)$$

shakldagi ekvivalent tengsizlikka keltiriladi:

$$ax + b > cx + d \Leftrightarrow ax - cx > d - b \Leftrightarrow x \cdot (a - c) > d - b \Leftrightarrow kx > n,$$

bunda  $k = a - c$ ,  $n = d - b$ .

$\geq$ ,  $<$  va  $\leq$  ishorali tengsizliklar ham shu kabi ekvivalent tengsizlik bilan almashtiriladi.

T a' r i f. Bir o'zgaruvchili tengsizlikning yechimi deb o'zgaruvchining tengsizlikni to'g'ri sonli tengsizlikka aylantiruvchi qiymatlari to'plamiga aytiladi.

Tengsizlikni yechish – uning hamma yechimlarini topish yoki yechimlari yo'qligini isbotlash demakdir.

Tengsizlikning yechimlari to'plami sonli oraliqlardan iborat bo'ladi.

**9.2. Sonli oraliqlar.** T a' r i f. Sonli oraliq deb oraliqning oxirlari deb ataluvchi sonlar orasidagi barcha sonlar to'plamiga aytiladi.

Sonli oraliqlar ushbu turlari bilan farqlanadi:

1.  $a \leq x \leq b$  ( $a$  va  $b$  – berilgan haqiqiy sonlar) tengsizlikni qanoatlantiradigan  $x$  sonlar to'plami *kesma* yoki *segment* deb ataladi va  $[a; b]$  kabi belgilanadi.  $a$  va  $b$  kesmaning *oxirlari* deb ataladi.

2.  $a < x < b$  tengsizlikni qanoatlantiradigan  $x$  sonlar to'plami *interval* yoki *oraliq* deb ataladi va  $(a; b)$  kabi belgilanadi.

3.  $a \leq x < b$  yoki  $a < x \leq b$  tengsizlikni qanoatlantiruvchi  $x$  sonlar to'plami *yarim ochiq kesma* yoki *yarim yopiq oraliq* deb ataladi va mos ravishda  $[a; b)$  yoki  $(a; b]$  kabi belgilanadi.

Bulardan tashqari cheksiz yoki yarim cheksiz deb ataluvchi ushbu oraliqlar ham qaralishi mumkin:

$$(-\infty; +\infty), (-\infty; a), (-\infty; a], (a; +\infty), [a; +\infty).$$

**9.3. Bir o'zgaruvchili tengsizliklarni yechish.** Tengsizliklarni yechishga misollar keltiramiz.

1-misol.  $7x - 6 < x + 12$  tengsizlikni yeching.

Yechilishi:  $7x - 6 < x + 12 \Leftrightarrow 7x - x < 12 + 6 \Rightarrow 6x < 18 \Rightarrow x < 3$ . Tengsizlikning yechimlar to'plami 3 dan kichik hamma

sonlardan iborat. Bu to'plam 15-rasmda tasvirlangan  $(-\infty; 3)$  sonli oraliqdan iborat.



15-rasm

Javob:  $x \in (-\infty; 3)$ , bunda  $\in$  – tegishlilik belgisi.

2-misol.  $1 - 2x \geq 4 - 5x$  tengsizlikni yeching.



16-rasm

Yechilishi:  $1 - 2x \geq 4 - 5x \Leftrightarrow 5x - 2x \geq 4 - 1 \Leftrightarrow 3x \geq 3 \Rightarrow x \geq 1$ .

Tengsizlikni qanoatlantiruvchi sonlar to'plami 16-rasmda tasvirlangan.

Javob:  $x \in [1; \infty)$ .

3-misol.  $9 - 7x > -1 - 17x$  tengsizlikni yeching.

Yechilishi:  $9 - 7x > -1 - 17x \Leftrightarrow 17x - 7x > -1 - 9 \Leftrightarrow 10x > -10 \Rightarrow x > -1$ .

Tengsizlikni qanoatlantiruvchi sonlar to'plami 17-rasmda tasvirlangan.

Javob:  $x \in (-1; +\infty)$ .

4-misol.  $-\frac{2}{3-x} > 0$  tengsizlikni yeching.

Yechilishi:  $-\frac{2}{3-x} > 0 \Leftrightarrow$

$\Leftrightarrow \frac{2}{x-3} > 0 \Leftrightarrow x-3 > 0 \Rightarrow [x > 3.$

Tengsizlikni qanoatlantiruvchi sonlar to'plami 18-rasmda tasvirlangan.

Javob:  $x \in (3; +\infty).$

5-misol.  $\frac{4}{2+x} < 0$  tengsizlikni yeching.

Yechilishi:  $\frac{4}{2+x} < 0 \Leftrightarrow$

$\Leftrightarrow 2+x < 0 \Rightarrow [x > -2.$

Tengsizlikni qanoatlantiruvchi sonlar 19-rasmda tasvirlangan.

Javob:  $x \in (-\infty; -2).$

6-misol.  $x - \frac{2x+3}{3} \leq \frac{x-1}{4}$  tengsizlikni yeching.

Yechilishi:  $x - \frac{2x+3}{3} \leq \frac{x-1}{4} \Leftrightarrow \frac{12x - 8x - 12 - 3x + 3}{12} \leq 0 \Leftrightarrow$

$\Leftrightarrow x - 9 \leq 0 \Rightarrow [x \leq 9.$

Tengsizlikni qanoatlantiruvchi sonlar to'plami 20-rasmda tasvirlangan.

Javob:  $x \leq 9.$



18-rasm



19-rasm

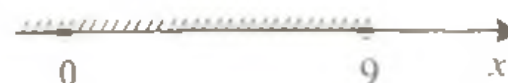

20-rasm

### 10-§. Chiziqli tengsizliklar sistemasi

Ta'rif. Chiziqli tengsizliklar sistemasi deb, bir xil noma'lum o'zgaruvchiga ega bo'lgan ikki yoki undan ortiq chiziqli tengsizliklar to'plamiga aytiladi.

Ushbu sistemalar chiziqli tengsizliklar sistemalariga misol bo'la oladi:

1)  $\begin{cases} 5x + 6 \leq x, \\ 3x + 12 \leq x + 17. \end{cases}$

2)  $\begin{cases} 2(x - 1) - 3(x - 2) \leq x, \\ 6x - 3 \leq 17 - (x - 5). \end{cases}$

3)  $\begin{cases} 3,3 - 3(1,2 - 5x) > 0,6(10x + 1), \\ 1,6 - 4,5(4x - 1) < 2x + 26,1. \end{cases}$

4)  $\begin{cases} 2x - 1 < x + 3, \\ 5x - 1 \geq 6 - 2x, \\ x - 5 < 0. \end{cases}$



21-rasm

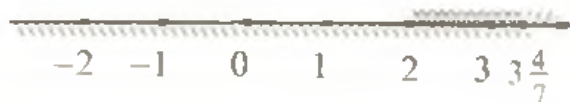

22-rasm

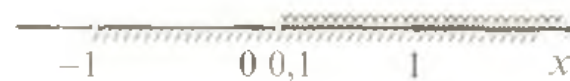

23-rasm

**10.1. Chiziqli tengsizliklar sistemasini yechish.** *Tengsizliklar sistemasini yechish noma'lum o'zgaruvchining sistemaning har qaysi tengsizligini qanoatlantiradigan barcha qiymatlari to'plamini topish demakdir.*

Yuqorida keltirilgan sistemalarni yechamiz:

$$1) \begin{cases} 5x + 6 \leq x, \\ 3x + 12 \leq x + 17. \end{cases} \Leftrightarrow$$

$$\Leftrightarrow \begin{cases} 5x - x \leq -6, \\ 3x - x \leq 17 - 12. \end{cases} \Leftrightarrow \begin{cases} 4x \leq -6, \\ 2x \leq 5 \end{cases} \Leftrightarrow$$

$$\Leftrightarrow \begin{cases} x \leq -1,5, \\ x \leq 2,5 \end{cases} \Rightarrow [x \leq -1,5.$$

Sistemaning yechimlari birlashmasi 21-rasmda tasvirlangan:

J a v o b:  $x \in (-\infty; -1,5]$ .

$$2) \begin{cases} 2(x - 1) - 3(x - 2) \leq x, \\ 6x - 3 \leq 17 - (x - 5). \end{cases} \Leftrightarrow \begin{cases} 2x - 2 - 3x + 6 - x \leq 0, \\ 6x - 3 + x \leq 17 + 5 \end{cases} \Leftrightarrow$$

$$\Leftrightarrow \begin{cases} -2x \leq -4, \\ 7x \leq 25 \end{cases} \Rightarrow \begin{cases} x \geq 2, \\ x \leq 3 \frac{4}{7} \end{cases} \Rightarrow \left[ 2 \leq x \leq 3 \frac{4}{7} \right].$$

Sistemaning yechimlar kesishmasi 22-rasmda tasvirlangan:

J a v o b:  $x \in \left[ 2; 3 \frac{4}{7} \right]$ .

$$3) \begin{cases} 3,3 - 3(1,2 - 5x) > 0,6(10x + 1), \\ 1,6 - 4,5(4x - 1) < 2x + 26,1 \end{cases} \Leftrightarrow \begin{cases} 3,3 - 3,6 + 15x > 6x + 0,6, \\ 1,6 - 18x + 4,5 < 2x + 26,1 \end{cases} \Leftrightarrow$$

$$\Leftrightarrow \begin{cases} 9x > 0,9, \\ -20x < 20 \end{cases} \Leftrightarrow \begin{cases} x > 0,1, \\ x > -1 \end{cases} \Rightarrow [x < 0,1.$$

Sistemaning yechimlar birlashmasi 23-rasmda tasvirlangan:

J a v o b:  $(0,1; +\infty)$ .

$$4) \begin{cases} 2x-1 < x+3, \\ 5x-1 \geq 6-2x, \\ x-5 < 0 \end{cases} \Leftrightarrow \begin{cases} 2x-x < 3+1, \\ 5x+2x \geq 6+1, \\ x < 5. \end{cases} \Leftrightarrow \begin{cases} x < 4, \\ x < 5, \\ 7x \geq 7. \end{cases} \Leftrightarrow \begin{cases} x < 4, \\ x \geq 1 \end{cases} \Rightarrow$$

$$\Rightarrow [1 \leq x < 4.$$

Sistemaning yechimlari kesishmasi 24-rasmda tasvirlangan:

J a v o b:  $x \in [1; 4)$ .

5) Ushbu

$$1 < \frac{2x-1}{2} < 2 \text{ qo'sh tengsizlikni yeching.}$$

Yechilishi. Berilgan qo'sh tengsizlik quyidagi tengsizliklar sistemasiga teng kuchlidir:

$$\begin{cases} \frac{2x-1}{2} > 1, \\ \frac{2x-1}{2} < 2 \end{cases}$$

Bu sistemani yechamiz:

$$\begin{cases} \frac{2x-1}{2} > 1, \\ \frac{2x-1}{2} < 2 \end{cases} \Leftrightarrow \begin{cases} 2x-1 > 2, \\ 2x-1 < 4 \end{cases} \Leftrightarrow \begin{cases} 2x > 3, \\ 2x < 5 \end{cases} \Leftrightarrow \begin{cases} x > 1,5, \\ x < 2,5 \end{cases} \Rightarrow$$

$$\Rightarrow [1,5 < x < 2,5.$$

J a v o b:  $x \in (1,5; 2,5)$ .

$$6) \begin{cases} 14x-3 \leq 7+9x, \\ 1 < x-3 \end{cases} \text{ tengsizliklar sistemasini yeching.}$$

$$\text{Yechilishi: } \begin{cases} 14x-3 \leq 7+9x, \\ 1 < x-3 \end{cases} \Leftrightarrow \begin{cases} 5x \leq 10, \\ x > 4 \end{cases} \Rightarrow \begin{cases} x \leq 2, \\ x > 4. \end{cases}$$

Koordinata to'g'ri chizig'ida sistemaning har bir tengsizligi yechimining tasviridan ko'rinib turibdiki (25-rasm),  $x \leq 2$  va  $x > 4$  tengsizliklarni qanoatlantiruvchi sonlar to'plami umumiy elementga ega emas, ya'ni ularning kesishmasi bo'sh to'plam.



24-rasm

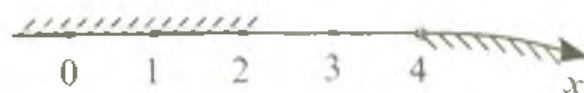

25-rasm

Haqiqatan ham, 2 dan katta emas va 4 dan katta bo'lishi kerak bo'lgan son mavjud emas.

Javob:  $x \in \emptyset$  (bunda  $\emptyset$  – bo'sh to'plam belgisi).

## 11-§. Chiziqli tengsizliklarni yechishning grafik usuli

11.1.  $kx > n$  tengsizlikni yechishning grafik usuli. Koordinatalar tekisligida

$$y = kx \text{ va } y = n$$

funksiyalarning grafiklarini yasaymiz. Agar  $k \neq 0$  bo'lsa,  $y = kx$  to'g'ri chiziq albatta  $y = n$  to'g'ri chiziqni kesadi ( $k > 0$ , 26-rasm;  $k < 0$ , 27-rasm). Bu to'g'ri chiziqning kesishish nuqtasini  $M$  harfi bilan belgilaymiz. Bu nuqtaning absissasi  $kx = n$  tenglamaning ildizi  $x = \frac{n}{k}$  ga teng. Agar  $k > 0$  bo'lsa, 26-rasmda ko'rinib turganidek, barcha  $x > \frac{n}{k}$  lar uchun  $kx > n$  tengsizlik to'g'ri tengsizlik bo'ladi. Agar  $k < 0$  bo'lsa (27-rasm), barcha  $x < \frac{n}{k}$  lar uchun  $kx > n$  bo'ladi.

11.2. Bir o'zgaruvchili chiziqli tengsizliklar sistemasini grafik usul bilan yechish. Ushbu masalani qaraylik: «O'zgaruvchi  $x$  ning qanday qiymatlarida  $y = x + 1$  va  $y = -2x + 4$  funksiyalarning har ikkisi ham nomanfiy qiymatlar qabul qiladi?»

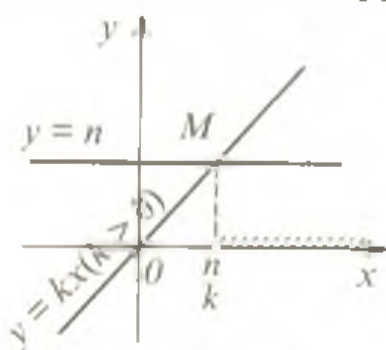

26-rasm

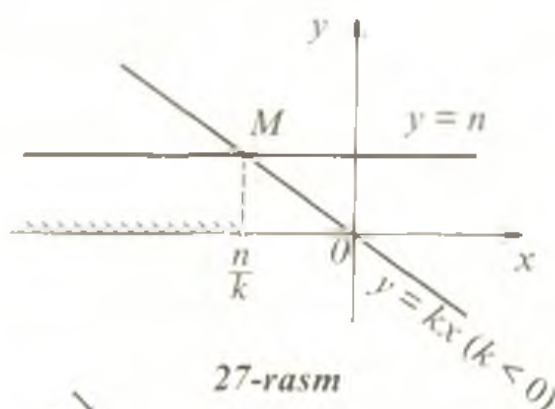

27-rasm

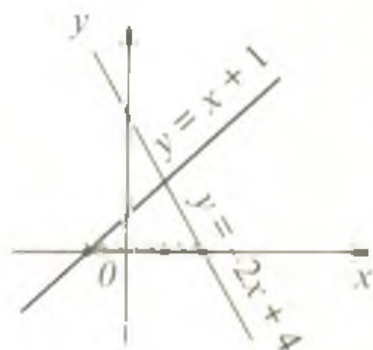

28-rasm

Berilgan funksiyalarning grafiklarini bir chizmada tasvirlash yo'li bilan bu masalani osongina yechish mumkin. Bu grafiklar 28-rasmda tasvirlangan.

O'zgaruvchi  $x$  ning izlanayotgan qiymatlari to'plami  $[-1; 2]$  kesmadan iborat ekan.

## 12-§. Noma'lumlari modul belgisi ostida bo'lgan tenglamalar va tengsizliklar

**12.1. Modulli tenglamalar.** Ba'zi tenglamalarning noma'lumlari modul (absolut qiymat) belgisi ostida bo'ladi. Bunday tenglamalarning yechilishi biror o'zgaruvchi  $x$  miqdorning absolut qiymati  $a$  musbat songa teng bo'lsa, bu holda  $x$  ning o'zi yo  $a$  ga, yoki  $-a$  ga teng bo'lishiga asoslanadi. Masalan,  $|x| = 5$  bo'lsa,  $x = 5$  yoki  $x = -5$ .

Bir necha misollar qaraylik:

1-misol.  $|x - 1| = 2$  tenglamani yeching.

Yechilishi: ta'rifga ko'ra

$$\begin{cases} x - 1 > 0, \\ x - 1 = 2 \end{cases} \Rightarrow \begin{cases} x > 1, \\ x = 3 \end{cases}$$

yoki

$$\begin{cases} x - 1 < 0, \\ x - 1 = -2 \end{cases} \Rightarrow \begin{cases} x < 1, \\ x = -1 \end{cases}$$

$$\Rightarrow \begin{cases} x_1 = 3 \\ x_2 = -1. \end{cases}$$

O'zgaruvchi  $x$  ning bu ikkala qiymati ham berilgan tenglamani qanoatlantiradi.

Javob: 3; -1.

2-misol.  $|6 - 2x| = 3x + 1$  tenglamani yeching.

Yechilishi: ta'rifga ko'ra

$$\begin{cases} 6 - 2x > 0, \\ 6 - 2x = 3x + 1 \end{cases} \Rightarrow \begin{cases} -2x > -6, \\ -5x = -5 \end{cases} \Rightarrow \begin{cases} x < 3, \\ x = 1. \end{cases}$$

$$\begin{cases} 6 - 2x < 0, \\ 6 - 2x = -3x - 1 \end{cases} \Rightarrow \begin{cases} -2x < -6, \\ x = -7 \end{cases} \Rightarrow \begin{cases} x > 3, \\ x = -7. \end{cases}$$

Haqiqatan ham,  $x = -7$  berilgan tenglamani qanoatlantirmaydi:  $x = -7$  da  $|6 - 2x| = |20| = 20$ ,  $3x + 1 = -21 + 1 = -20$ ,  $20 \neq -20$ .

Javob: 1.



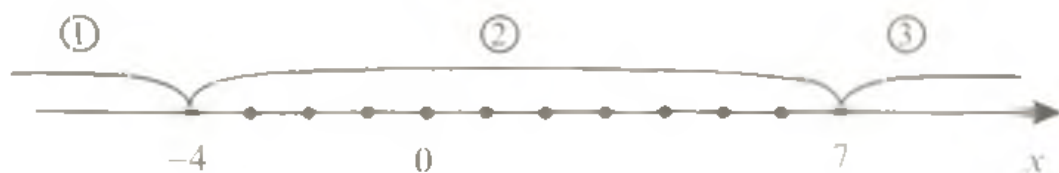

29-rasm

**12.2. Oraliqlar usuli.** Noma'lumlari modul belgisi ostida bo'lgan ba'zi tenglamalarni yechishda ko'pincha *oraliqlar usuli* deb ataluvchi usuldan foydalaniladi. Bu usulni ushbu

$$|56 - 8x| + |36x + 144| = 356$$

tenglama misolida tushuntiramiz. Bu tenglamada ikkita modul ostidagi ifoda bor:  $56 - 8x$  va  $36x + 144$ . Bulardan birining noli  $x = 7$ , ikkinchisining  $x = -4$ . Absissalari mos ravishda  $-4$  va  $7$  ga teng bo'lgan nuqtalar koordinatalar chizig'ini uchta oraliqqa bo'ladi (29-rasm). Bu uch oraliqning har birida  $|56 - 8x|$  va  $|36x + 144|$  ifodalar modul belgisiz osongina yoziladi:

$$|56 - 8x| = \begin{cases} 56 - 8x, & \text{birinchi va ikkinchi oraliqlarda,} \\ -56 + 8x, & \text{uchinchi oraliqda.} \end{cases}$$

$$36x + 144 = \begin{cases} -36x - 144, & \text{birinchi oraliqda,} \\ 36x + 144, & \text{ikkinchi va uchinchi oraliqlarda.} \end{cases}$$

Yozilgan bu tengliklarni hisobga olib, berilgan tenglamani har bir oraliq uchun yechamiz:

$$1) x < -4; \quad 56 - 8x - 36x - 144 = 356 \Rightarrow x = -10\frac{1}{11};$$

$$2) -4 \leq x < 7; \quad 56 - 8x + 36x + 144 = 356 \Rightarrow x = 5\frac{4}{7};$$

$$3) x \geq 7; \quad -56 + 8x + 36x + 144 = 356 \Rightarrow x = 6\frac{1}{11} < 7$$

(qaralayotgan uchinchi oraliqqa tegishli emas, shu sababli  $x$  ning  $6\frac{1}{11}$  ga teng qiymati tenglama ildizi emas).

$$\text{J a v o b: } -10\frac{1}{11}; 5\frac{4}{7}.$$

**12.3. Modulli tengsizliklar.** Modulli tengsizliklarni yechishda

$$|f(x)| = \begin{cases} f(x), & \text{agar } f(x) \geq 0, \\ -f(x), & \text{agar } f(x) < 0 \end{cases}$$

tenglikdan foydalaniladi. Bundan tashqari, geometrik talqiniga ko'ra  $|x|$  sonlar o'qida absissasi  $x$  ga teng bo'lgan nuqtadan sanoq boshigacha bo'lgan masofani,  $|x - a|$  esa absissalari mos ravishda  $x$  va  $a$  ga teng bo'lgan nuqtalar orasidagi masofani anglatishidan foydalanish maqsadga muvofiqdir. Ba'zi hollarda ushbu tengkuchlilik xossalari tengsizliklar yechimlarini topishni qulaylashtiradi:

$$f(x) \leq g(x) \Leftrightarrow \begin{cases} f(x) \leq g(x), \\ f(x) \geq -g(x) \end{cases} \quad (\text{A})$$

$$|f(x)| \geq g(x) \Leftrightarrow \begin{cases} f(x) \geq g(x), \\ f(x) \leq -g(x) \end{cases} \quad (\text{B})$$

Bu tengkuchlilik xossalarida «  $\{$  » belgi to'plamlar kesishmasini ifodalasa, «  $[$  » belgi to'plamlar birlashmasini ifodalaydi.

$$|f(x)| > |g(x)| \Leftrightarrow (f(x))^2 > (g(x))^2, \quad (\text{C})$$

$$f(x) < g(x) \Leftrightarrow (f(x))^2 < (g(x))^2. \quad (\text{D})$$

Ayrim tengsizliklarni yechishda oraliqlar usulidan ham foydalaniladi. Biz bu paragrafda

$$|ax + b| > c, \quad |ax + b| > cx + d,$$

$$|a_1x + b_1| + |a_2x + b_2| + \dots + |a_nx + b_n| > f(x)$$

$$(f(x) = \text{const ham bo'lishi mumkin})$$

ko'rinishdagi tengsizliklarni yechilishini misollarda ko'rib chiqamiz. Bayon qilinayotgan mulohazalar  $<$ ,  $\geq$ ,  $\leq$  belgili tengsizliklar uchun o'rinli ekanligi tabiiydir.



30-rasm

1-misol.  $|x - 1| < 3$  tengsizlikni yeching.

Yechilishi. Agar biror sonning moduli 3 dan kichik bo'lsa, bu sonning o'zi  $-3$  dan katta, ammo 3 dan kichik bo'lishi kerak (30-rasmga qarang).

Shu sababli berilgan tengsizlikni

$$-3 < x - 1 < 3$$

ko'rinishdagi qo'sh tengsizlik ko'rinishida yozish mumkin. Shu tengsizlikni yechamiz:

$$-3 < x - 1 < 3 \Leftrightarrow -2 < x < 4.$$

$x$  ning bu qiymatlar to'plami 31-rasmda tasvirlangan.

Javob:  $x \in (-2; 4)$ .



31-rasm



32-rasm

2-misol.  $|3 - x| > 2$  tengsizlikni yeching.

Yechilishi. Agar biror sonning moduli 2 dan katta bo'lsa, bu sonning o'zi yo  $-2$  dan kichik, yoki  $2$  dan katta bo'lishi kerak (32-rasm). Shuning uchun berilgan tengsizlikdan  $3 - x < -2$  yoki  $3 - x > 2$  ekanligi kelib chiqadi. Bundan (33-rasm).

$$-x < -5 \Leftrightarrow x > 5,$$

yoki

$$-x > -1 \Leftrightarrow x < 1,$$

Javob:  $x \in (-\infty; 1) \cup (5; +\infty)$ .

3-misol.  $|x - 2| \geq x - 2$  tengsizlikni yeching.

Yechilishi:

$$|x - 2| \geq x - 2 \Leftrightarrow \begin{cases} x - 2 \geq 0, \\ x - 2 \geq x - 2 \end{cases} \Leftrightarrow \begin{cases} x \geq 2, \\ 0 \geq 0 \end{cases} \Rightarrow [x \geq 2$$

$$\Leftrightarrow \begin{cases} x - 2 < 0, \\ -(x - 2) \geq x - 2 \end{cases} \Leftrightarrow \begin{cases} x < 2, \\ x \leq 2 \end{cases} \Rightarrow [x < 2.$$

Javob:  $x \in (-\infty; +\infty)$ .

4-misol.  $|2x - 6| < 9x - 5$  tengsizlikni yeching.



33-rasm



34-rasm

**Yechilishi:** Bunday tengsizliklarni hechayotganda (A) teng kuchlilik xossasidan foydalanish mumkin. Shunga asoslanib, ushbu yechimni olamiz:

$$|2x - 6| < 9x - 5 \Leftrightarrow \begin{cases} 2x - 6 < 9x - 5, \\ 2x - 6 > -9x + 5 \end{cases} \Leftrightarrow \begin{cases} 7x > -1, \\ 11x > 11 \end{cases} \Rightarrow$$

$$\Rightarrow \begin{cases} x > -\frac{1}{7}, \\ x > 1 \end{cases} \Rightarrow [x > 1.$$

**Javob:**  $x \in (1; +\infty)$ .

5-misol.  $|x - 3| \geq 2x + 1$  tengsizlikni yeching.

**Yechilishi.** (B) tengkuchlilik xossasidan foydalanamiz:

$$|x - 3| \geq 2x + 1 \Leftrightarrow \begin{cases} x - 3 \geq 2x + 1, \\ x - 3 \leq -2x - 1 \end{cases} \Leftrightarrow \begin{cases} x \leq -4, \\ 3x \leq 2 \end{cases} \Leftrightarrow \begin{cases} x \leq -4, \\ x \leq \frac{2}{3} \end{cases} \Rightarrow$$

$$[x \leq \frac{2}{3}.$$

**Javob:**  $x \in (-\infty; \frac{2}{3}]$ .

6-misol.  $|x| + |x - 1| + |x - 2| < 4$  tengsizlikni yeching.

**Yechilishi.** Tengsizlikni oraliqlar usulidan foydalanib yechamiz. Modul ostidagi ifodalarning nollari son o'qini to'rtta oraliqqa bo'ladi (34-rasm).

Har bir oraliqda tengsizlik tarkibidagi modulli ifodalarni modul belgisiz yozamiz:

$$x = \begin{cases} x, 2; 3; 4 & - \text{oraliqlarda,} \\ -x, 1 & - \text{oraliqda,} \end{cases} \quad x-1 = \begin{cases} x-1, 3; 4 & - \text{oraliqlarda,} \\ -x+1, 1; 2 & - \text{oraliqlarda.} \end{cases}$$

$$|x-2| = \begin{cases} x-2, 4 & - \text{oraliqda,} \\ -x+2, 1; 2; 3 & - \text{oraliqlarda.} \end{cases}$$

Shunday qilib, berilgan tengsizlik ushbu tengsizliklar sistemalarining to'plamiga teng kuchli bo'ladi:

$$\begin{cases}
 1) \begin{cases} x < 0 \\ -x - x + 1 - x + 2 < 4 \Leftrightarrow -3x < 1 \Rightarrow \begin{cases} x < 0 \\ x > -\frac{1}{3} \end{cases} \Leftrightarrow -\frac{1}{3} < x < 0.
 \end{cases} \\
 2) \begin{cases} 0 \leq x < 1 \\ x - x + 1 - x + 2 < 4 \Leftrightarrow -x < 1 \Leftrightarrow \begin{cases} 0 \leq x < 1 \\ x > -1 \end{cases} \Leftrightarrow 0 \leq x < 1.
 \end{cases} \\
 3) \begin{cases} 1 \leq x < 2 \\ x + x - 1 - x + 2 < 4 \Leftrightarrow x < 3 \Leftrightarrow \begin{cases} 1 \leq x < 2 \\ x < 3 \end{cases} \Leftrightarrow 1 \leq x < 2. \Leftrightarrow \\
 4) \begin{cases} x \geq 2 \\ x + x - 1 + x - 2 < 4 \Leftrightarrow 3x < 7 \Rightarrow \begin{cases} x \geq 2 \\ x < \frac{7}{3} \end{cases} \Rightarrow 2 \leq x < \frac{7}{3}.
 \end{cases}
 \end{cases}$$

$$\Leftrightarrow -\frac{1}{3} < x < \frac{7}{3}. \text{ Javob: } x \in \left(-\frac{1}{3}; \frac{7}{3}\right).$$

### Mustaqil ishlash uchun test topshiriqlari

1. Tenglamani yeching:  $\frac{2}{3} \left(\frac{1}{3}x + 0,2\right) = \frac{2}{9}x + \frac{2}{15}$ .

A)  $\frac{3}{5}$ ; B)  $\frac{5}{3}$ ; C) cheksiz ko'p yechimga ega; D)  $-\frac{1}{2}$ ; E)  $\frac{1}{5}$ .

2.  $2,8x - 3(2x - 1) = 2,8 - 3,19x$  tenglamani yeching.

A) -2; B) 200; C) 0,2; D) 20; E) -20.

3\*.  $(m^2 - 1)x + 3 = 0$  tenglama yechimga ega bo'lmaydigan  $t$  ning qiymatlari ko'paytmasini toping.

A) 1; B) 0; C) -2; D) 2; E) -1.

4\*.  $a$  ning qanday qiymatlarida

$$\begin{cases}
 ax - y = 0, \\
 x + y = 10
 \end{cases}$$

tenglamalar sistemasi yechimga ega bo'lmaydi?

A)  $\pm 1$ ; B) -1; C) 1; D)  $\pm 2$ ; E) 2.

5. Xo'jalikdagi 12120 ga maydonga bug'doy, paxta va beda ekildi. Hamma yerning 30% iga bug'doy ekilgan bo'lib, paxta beda ekilgan yerdan 6244 ga ortiq yerga ekilgan bo'lsa, necha gektar yerga paxta ekilganini toping.

A) 3630; B) 7364; C) 1830; D) 6510; E) 7464.

6. Fermer xo'jaligida qo'ylar va tovuqlar boqiladi. Qo'y va tovuqlar boshlarining soni 170 ta, oyoqlarining soni 440 ta bo'lsa, qo'ylar soni tovuqlar sonidan nechtaga kamligini aniqlang.

- A) 45;      B) 60;      C) 70;      D) 80;      E) 90.

7. 
$$\begin{cases} 100x - 2y = 96, \\ -3x + 57y = 111 \end{cases}$$
 tenglamalar sistemasini qanoatlantiradigan sonlar juftini ko'rsating.

- A) (2; 1);      B) (-2; 1);      C) (2; 52);      D) (2; -52);      E) (1; 2).

8\*.  $k$  ning qanday qiymatlarida 
$$\begin{cases} 3x + (k - 1)y = k + 1, \\ (k + 1)x + y = 3 \end{cases}$$
 tenglamalar sistemasi cheksiz ko'p yechimga ega bo'ladi?

- A) -4;      B) -1;      C) 0;      D) 2;      E) 1.

9. Kastum paltodan 5950 so'm arzon. Agar palto kastumdan 1,7 marta qimmat bo'lsa, kastum necha so'm turadi?

- A) 8450;      B) 7560;      C) 4500;      D) 8500;      E) 970.

10.  $\left(4\frac{3}{8}x + 5\frac{1}{16}\right) \cdot \frac{4}{15} = \frac{5}{12}x + 2\frac{2}{5}$  tenglamani yeching.

- A)  $\frac{3}{17}$ ;      B)  $1\frac{2}{5}$ ;      C)  $\frac{1}{15}$ ;      D)  $2\frac{1}{5}$ ;      E)  $\frac{7}{15}$ .

11. To'rtta qalam va uchta ruchkaning birgalikdagi narxi 260 so'm, ikkita qalam va ikkita ruchkaniki esa 140 so'mga teng. Ruchkaning narxini aniqlang.

- A) 10;      B) 20;      C) 30;      D) 25;      E) 35 so'm.

12. Agar  $k > 0$  va  $b > 0$  bo'lsa,  $y = kx + b$  funksiya grafigi koordinatalar tekisligining qaysi choraklarida joylashadi?

- A) I, II va III;      B) I va II;      C) I, III, IV;      D) II, III, IV;      E) I, II va IV.

13. Ko'rsatilgan nuqtalardan qaysi biri  $y = -2x + 4$  funksiya grafigiga tegishli?

- A) (-2; 3);      B) (2; 3);      C) (3; -2);      D) (2; 4);      E) (4; 2).

14.  $A(3; 2)$  va  $B(a; -1)$  nuqtalar  $Oy$  o'qiga parallel to'g'ri chiziqda yotadi.  $B$  nuqtaning absissasi  $a$  ni toping.

- A) 4;      B) 2;      C) 3;      D) 0;      E) -1.

15. Ordinatalar o'qiga parallel bo'lgan to'g'ri chiziqda  $A(3; 5)$  va  $B(x; y)$  nuqtalar berilgan.  $x$  ning qiymati nechaga teng?

- A) -3;      B) -5;      C) 3;      D) 8;      E) -3.

16.  $A(-6; 3)$  va  $B(2; -3)$  nuqtalar berilgan. Shu ikki nuqta orasidagi masofa uzunligini toping.

- A) 10;      B) 8;      C) 6;      D)  $\sqrt{10}$ ;      E)  $\sqrt{8}$ .

17. Agar  $P(1; 3)$  va  $Q(4; 5)$  bo'lsa,  $PQ$  kesma o'rtasining koordinatalarini toping.

A)  $(1,5; -1)$ ; B)  $(2; 2,5)$ ; C)  $(-2,5; 4)$ ; D)  $(2,5; 4)$ ; E)  $(4; 2,5)$ .

18.  $M(-4; 0)$  nuqtani koordinata boshi atrofida  $90^\circ$  burganda u qanday nuqtaga o'tadi?

A)  $(4; 4)$ ; B)  $(0; -4)$ ; C)  $(-4; 4)$ ; D)  $(4; 0)$ ; E)  $(0; 4)$ .

19. Uchlari  $A(2; 6)$  va  $B(-3; 2)$  nuqtalarda bo'lgan  $AB$  kesmani  $\frac{1}{4}$  nisbatda bo'luvchi  $C(x; y)$  nuqta koordinatalarini toping.

A)  $(0,25; 0,5)$ ; B)  $(-0,25; 0,5)$ ; C)  $(1; 5,2)$ ;

D)  $(5,2; 1)$ ; E)  $(-1; 5,2)$ .

20.  $y = \frac{1}{2}x - 3$  va  $y = 0,5x + 3$  tenglamalar bilan berilgan to'g'ri chiziqlar qaysi nuqtada kesishishini aniqlang.

A)  $(\frac{1}{2}; -3)$ ; B)  $(\frac{1}{2}; 3)$ ; C)  $(2,5; 3,5)$ ; D)  $(2,5; 3,5)$ ; E) Bu to'g'ri chiziqlar kesishmaydi.

21. Ota 50 yoshda, o'g'il esa 20 yoshda. Necha yil avval o'g'il otadan 3 marta yosh bo'lgan?

A) 5; B) 4; C) 3; D) 2; E) 6.

22.  $\frac{1}{y-3} + \frac{4}{y+1} = \frac{4}{(y+1)(y-3)}$  tenglamani yeching.

A) 3; B) -3; C) 1; D) -1; E) tenglama yechimga ega emas.

23.  $a = 0,43(41)$ ,  $b = 0,4(341)$  va  $c = \frac{3}{7}$  sonlarni o'sish tartibida yozing.

A)  $b < c < a$ ; B)  $c < b < a$ ; C)  $b < a < c$ ;

D)  $c < a < b$ ; E)  $a < b < c$ .

24.  $a = |-3, (8)|$ ,  $b = |3,85|$  va  $c = 1 : \frac{7}{27}$  sonlarni kamayish tartibida yozing.

A)  $a > b > c$ ; B)  $b > a > c$ ; C)  $b > c > a$ ;

D)  $c > b > a$ ; E)  $a > c > b$ .

25. Quyidagi tengsizliklardan qaysi biri noto'g'ri?

A)  $a(a+b) \geq ab$ ; B)  $m^2 - mn + n^2 \geq mn$ ; C)  $2bc \leq b^2 + c^2$ ;

D)  $(a-3)^2 \geq 0$ ; E)  $\frac{(1+a)^2}{2} \leq 2a$ .

26.  $2(x+8) - 10x < 4 - 8x$  tengsizlikni yeching.

A)  $(-\infty; -2)$ ; B)  $(-\infty; -12)$ ; C)  $(-\infty; 1,2)$ ;

D)  $(-\infty; 1,2]$ ; E)  $\emptyset$ .

27.  $x(x-4) - x^2 > 12 - 6x$  tengsizlikning eng kichik butun yechimini ko'rsating.

- A) 6; B) 7; C) 2; D) -1; E) 5.

28.  $\frac{4-x}{5} - 5x \geq 0$  tengsizlikni yeching.

- A)  $x \in \left(\frac{2}{13}; +\infty\right)$ ; B)  $x \in \left(-\infty; -\frac{2}{13}\right)$ ; C)  $x \in \left(-\infty; \frac{2}{13}\right]$ ;

- D)  $x \in \left(-\infty; 6\frac{1}{2}\right]$ ; E)  $x \in \left[-6\frac{1}{2}; +\infty\right)$ .

29.  $2(3x-5)(x-1) - 3\left(1 - (2x+1)(3-x) + \frac{4-x}{2}\right) < 13$  tengsizlikning natural yechimlari yig'indisini toping.

- A) 0; B) 13; C) 15; D) 10; E) 11.

30.  $(3 - \sqrt{10})(2x - 7) < 0$  tengsizlikni yeching.

- A)  $x \in (\sqrt{10}; 3,5)$ ; B)  $x \in (3; \sqrt{10})$ ; C)  $x \in (-\infty; 3,5)$ ;

- D)  $x \in (3,5; +\infty)$ ; E)  $x \in (0; 3,5)$ .

31. Tengsizliklar sistemasini yeching:

$$\begin{cases} 3 - 2x \geq 0, \\ 4x + 8 < 0. \end{cases}$$

- A)  $x \in (-2; 1,5]$ ; B)  $x \in (-\infty; -2)$ ; C)  $x \in [1,5; +\infty)$ ;

- D)  $x \in (-\infty; -1,5]$ ; E)  $x \in (-\infty; -2) \cup [1,5; +\infty)$ .

32.  $\begin{cases} 4x + 2 \geq 5x + 3, \\ 2 - 3x < 7 - 2x \end{cases}$  tengsizliklar sistemasining butun yechim-

lari yig'indisini toping.

- A) 15; B) -15; C) 14; D) -14; E) -10.

33.  $\begin{cases} \frac{5x+7}{6} - \frac{3x}{4} < \frac{11x-7}{12}, \\ \frac{1-3x}{2} - \frac{1-4x}{3} \geq \frac{x}{6} - 1. \end{cases}$  tengsizliklar sistemasining butun

yechimlari nechta?

- A) 3; B) 4; C) 2; D) 1; E) butun yechimlari yo'q.

34.  $\begin{cases} 3x - 4 < 8x + 6, \\ 2x - 1 < 5x - 4, \\ 11x - 9 \leq 15x + 3 \end{cases}$  tengsizliklar sistemasini yeching.



- A)  $x \in (-2; 1)$ ;      B)  $x \in (1; +\infty)$ ;      C)  $x \in (-2; 6]$ ;  
D)  $x \in [-6; 1)$ ;      E)  $x \in [-2; 1]$ .
35. Ushbu  $-1 \leq 15x + 14 < 44$  qo'sh tengsizlikni yeching.  
A)  $(-1; 2)$ ;      B)  $[-1; 2)$ ;      C)  $(-\infty; -1] \cup (2; +\infty)$ ;  
D)  $[-1; 0] \cup (0; 2)$ ;      E)  $(-2; 1]$ .
36.  $-1 \leq \frac{6-x}{3} \leq 1$  qo'sh tengsizlikning yechimini ko'rsating.  
A)  $[-3; 3]$ ;      B)  $[-5; 5]$ ;      C)  $[3; 9]$ ;      D)  $[-9; -3]$ ;      E)  $[-9; 3]$ .
37.  $|84 - 5x| = 64$  tenglamaning ildizlarini toping.  
A) 4 yoki 29,6;      B) 4;      C) -4;      D) 29,6;      E)  $\pm 4$ .
38.  $|5 - x| - |x + 4| = 0$  tenglamani yeching.  
A)  $-\frac{1}{2}$ ;      B)  $-4\frac{1}{2}$ ;      C)  $4\frac{1}{2}$ ;      D)  $-\frac{1}{2}$  va  $\frac{9}{5}$ ;      E)  $\frac{1}{2}$ .
- 39\*.  $|x| + |x + 2| + |2 - x| = x + 1$  tenglama ildizlari nechta?  
A) ildizlari yo'q;      B) 1;      C) 2;      D) 3;      E) 4.
- 40\*.  $|x - 1| + |x + 1| = 2$  tenglamaning butun ildizlari nechta?  
A) Butun ildizlari yo'q;      B) 3;      C) 4;      D) 2;      E) 1.
41.  $|x - 3| > -1$  tengsizlikni yeching.  
A)  $x \in R$ ;      B)  $x \in (2; 4)$ ;      C)  $x \in (-\infty; 3) \cup (3; +\infty)$ ;  
D)  $x \in (-4; -2)$ ;      E)  $x \in [2; 4]$ .
42.  $|2x - 10| > 0$  tengsizlikni yeching.  
A)  $x \in (-\infty; +\infty)$ ;      B)  $x \in (5; +\infty)$ ;      C)  $x \in (-\infty; 5]$ ;  
D)  $x \in (-\infty; 5) \cup (5; +\infty)$ ;      E)  $x \in (-5; 5)$ .
43.  $1 < |x| < 2$  tengsizlikning butun yechimlari yig'indisini toping.  
A) 3;      B) -3;      C) 1;      D) -2;      E) butun yechimlari yo'q.
44.  $-1 < |2x - 3| < 7$  tengsizlikni yeching.  
A)  $x \in (1; 5)$ ;      B)  $x \in (-2; 5)$ ;      C)  $(1; 2)$ ;      D)  $(1; 2)$ ;      E)  $(-1; 2)$ .
- 45\*.  $|x - 1| < 2x - 4$  tengsizlikning eng kichik butun yechimini toping.  
A) 3;      B) 4;      C) 5;      D) 6;      E) -1.
- 46\*.  $|x - 4| > 2x - 1$  tengsizlikni yeching.  
A)  $x \in (-\infty; -3)$ ;      B)  $x \in (4; +\infty)$ ;      C)  $x \in (-\infty; \frac{5}{3})$ ;  
D)  $x \in (-\infty; 4)$ ;      E)  $x \in (-3; 4)$ .
- 47\*.  $|x - 1| + |x - 3| < x + 1$  tengsizlikning butun yechimlari yig'indisini toping.

A) 9;      B) 10;      C) 15;      D) 13;      E) 7.

48.  $|x| > a$  tengsizlik  $a$  ning qanday qiymatlarida har qanday  $x$  uchun o'rinli bo'ladi?

A)  $a \geq 0$ ;    B)  $a > 0$ ;    C)  $a \leq 0$ ;    D)  $a < 0$ ;    E)  $a \in R$ .

49\*.  $|x| + 2a - 1 \geq 0$  tengsizlik  $x$  ning ixtiyoriy qiymatida to'g'ri bo'lishi uchun  $a$  qanday qiymatlar qabul qilishi kerak?

A)  $a \leq 0$ ;    B)  $a \geq 0$ ;    C)  $a \geq$ ;      D)  $a > -\frac{1}{2}$ ;    E)  $a \in R$ .

50\*.  $\begin{cases} |x - 5| \leq 3, \\ |x - 4| \geq 2 \end{cases}$  tengsizliklar sistemasini yeching.

A)  $[2; 8]$ ;    B)  $[6; 8] \cup \{2\}$ ;    C)  $(-\infty; 8]$ ;    D)  $[6; +\infty)$ ;    E)  $[2; 6]$ .

## RATSIONAL KO'RSATKICHLI DARAJA

### 1-§. Kvadrat ildizlar

**1.1. Arifmetik kvadrat ildiz.**  $x^2 = a$  tenglamani qaraylik, bunda  $a$  – ixtiyoriy haqiqiy son. Bu tenglamani yechishda  $a$  songa bog'liq uch hol bo'lishi mumkin:

1) agar  $a < 0$  bo'lsa, u holda tenglamaning ildizlari bo'lmaydi, chunki kvadrati manfiy songa teng bo'ladigan son mavjud emas;

2) agar  $a = 0$  bo'lsa, u holda tenglama nolga teng bo'lgan yagona ildizga ega bo'ladi;

3) agar  $a > 0$  bo'lsa, tenglamaning ikkita ildizi bo'ladi. Ularning absolut qiymatlari teng bo'lib, faqat ishoralari bilan farqlanadi. Masalan,  $x^2 = 49$  tenglamaning ildizlari  $x_1 = -7$  va  $x_2 = 7$ . Bu ikkala son ham tenglamani to'g'ri tenglikka aylantiradi. Kvadrati 49 ga teng bo'lgan bu ikki son 49 ning kvadrat ildizlari deyiladi. Shunga o'xshash, 10 va  $-10$  sonlari 100 ning, 15 va  $-15$  sonlari 225 ning kvadrat ildizlaridir.

Umuman,  $a$  sonning kvadrat ildizi deb kvadrati  $a$  ga teng bo'lgan songa aytiladi. Qaralgan misollarda nomanfiy 7, 10, 15 sonlari mos ravishda 49 ning, 100 ning va 225 ning arifmetik kvadrat ildizi deyiladi.

**T a' r i f.** Nomanfiy  $a$  sonning arifmetik kvadrat ildizi deb kvadrati  $a$  ga teng bo'lgan nomanfiy  $b$  songa aytiladi.

$a$  sonning arifmetik kvadrat ildizi uchun  $\sqrt{a}$  belgilash qabul qilingan. Ta'rifga ko'ra  $\sqrt{a} = b$  bo'lsa,  $b^2 = a$  ( $b \geq 0$ ). Shu sababli,

$$\sqrt{4} = 2 (2^2 = 4); \sqrt{1,44} = 1,2 (1,2^2 = 1,44); \sqrt{0} = 0 (0^2 = 0)$$

va hokazo.

$\sqrt{a}$  ifoda ma'noga ega bo'ladigan istalgan  $a$  uchun

$$(\sqrt{a})^2 = a$$

tenglik to'g'ri bo'ladi.

**1.2 Arifmetik kvadrat ildizning xossalari.** 1. Agar  $a \geq 0$  va  $b \geq 0$  bo'lsa, u holda

$$\sqrt{ab} = \sqrt{a} \cdot \sqrt{b}.$$

Shunga o'xshash, agar  $a \geq 0$ ,  $b \geq 0$ ,  $c \geq 0$  bo'lsa,

$$\sqrt{abc} = \sqrt{a} \cdot \sqrt{b} \cdot \sqrt{c}.$$

2. Agar  $a \geq 0$  va  $b > 0$  bo'lsa, u holda

$$\sqrt{\frac{a}{b}} = \frac{\sqrt{a}}{\sqrt{b}}.$$

Misollar:

$$1) \sqrt{64 \cdot 900} = \sqrt{64} \cdot \sqrt{900} = 8 \cdot 30 = 240.$$

$$2) \sqrt{49 \cdot 64 \cdot 0.25} = \sqrt{49} \cdot \sqrt{64} \cdot \sqrt{0.25} = 7 \cdot 8 \cdot 0.5 = 28.$$

$$3) \sqrt{1.69 \cdot 0.09 \cdot 0.0001} = \sqrt{1.69} \cdot \sqrt{0.09} \cdot \sqrt{0.0001} = \\ = 1.3 \cdot 0.3 \cdot 0.01 = 0.0039.$$

$$4) \sqrt{\frac{25}{36} \cdot \frac{49}{64} \cdot \frac{256}{9}} = \sqrt{\frac{25}{36}} \cdot \sqrt{\frac{49}{64}} \cdot \sqrt{\frac{256}{9}} = \frac{5}{6} \cdot \frac{7}{8} \cdot \frac{16}{3} = \frac{35}{9} = 3\frac{8}{9}.$$

$$5) \sqrt{117^2 - 108^2} = \sqrt{(117 - 108)(117 + 108)} = \sqrt{9 \cdot 225} = \\ = \sqrt{9} \cdot \sqrt{225} = 3 \cdot 15 = 45.$$

3.  $a$  ning istalgan qiymatida

$$\sqrt{a^2} = |a|$$

tenglik o'rinlidir.

Misollar:

$$1) \sqrt{a^{18}} = \sqrt{(a^9)^2} = |a^9|. \quad 2) 2 \sqrt{-23^2} = 2 \cdot |-23| = 2 \cdot 23 = 46.$$

$$3) -\sqrt{0.25y^2} = -0.5|y| = \begin{cases} -0.5y, & \text{agar } y \geq 0 \text{ bo'lsa,} \\ 0.5y, & \text{agar } y < 0 \text{ bo'lsa.} \end{cases}$$

$$4) \sqrt{28224} = \sqrt{2^6 3^2 7^2} = \sqrt{(2^3)^2 3^2 7^2} = 8 \cdot 3 \cdot 7 = 168.$$

2-§.  $y = x^2$  va  $y = \sqrt{x}$  funksiyalar.

*Ularning grafiklari*

**2.1.  $y = x^2$  funksiya.** Bu funksiyaning asosiy xossalarini keltirib o'tamiz:

1) Agar  $x = 0$  bo'lsa,  $y = 0$ .

2) Erkli o'zgaruvchi  $x$  ning nomanfiy qiymatlarida funksiya o'suvchidir, ya'ni argumentning katta qiymatiga funksiyaning katta qiymati mos keladi.

$(-\infty; 0]$  oraliqda esa, argumentning katta qiymatiga funktsiyaning kichik qiymati mos kelib, funktsiya kamayadi.

3) Agar  $x$  argumentning musbat qiymatlari cheklanmay orttirilsa, funktsiya musbat cheksizlikka intiladi.

4) Agar  $x$  argumentning ishorasi qarama-qarshisiga o'zgartirilsa, funktsiyaning qiymati o'zgarmaydi, haqiqatan ham  $(-x)^2 = x^2$ . Bunday xossaga ega bo'lgan funktsiya *juft funktsiya* deyiladi.  $y = x^2$  funktsiya juft funktsiyadir. Uning grafigi ordinatalari o'qiga nisbatan simmetrik.

Funktsiya grafigi 35-rasmda keltirilgan. Bu egri chiziq *parabola* deb ataladi.

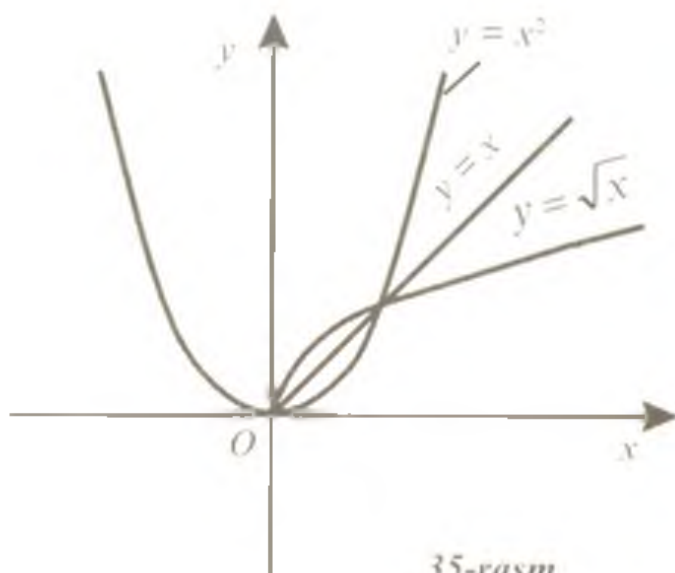

35-rasm

**2.2.  $y = \sqrt{x}$  funktsiya.** Bu funktsiya nomanfiy sonlar to'plamida aniqlangan bo'lib, uning qiymatlari ham nomanfiy sonlardan iborat. Funktsiyaning aniqlanish sohasidan olingan argumentning katta qiymatiga funktsiyaning katta qiymati mos keladi: funktsiya o'suvchi.  $y = \sqrt{x}$  funktsiya grafigi  $y = x^2$  funktsiya grafigiga  $y = x$  to'g'ri chiziqqa nisbatan simmetrik bo'lgan yarim paraboladan iborat ( $x \geq 0$ ) (35-rasm).

### 3-§. Kvadrat ildizlar qatnashgan ifodalarni shakl almashtirish

Kvadrat ildizlar qatnashgan ifodalarni aynan shakl almashtirishga doir misollar ko'rib chiqamiz.

1-misol.  $3\sqrt{20} + 5\sqrt{45} - 2\sqrt{80}$  ifodani soddalashtiring.

Ye'chilishi:  $3\sqrt{20} + 5\sqrt{45} - 2\sqrt{80} = 3\sqrt{2^2 \cdot 5} + 5\sqrt{3^2 \cdot 5} - 2\sqrt{4^2 \cdot 5} = 3 \cdot 2\sqrt{5} + 5 \cdot 3\sqrt{5} - 2 \cdot 4\sqrt{5} = 6\sqrt{5} + 15\sqrt{5} - 8\sqrt{5} = 13\sqrt{5}$ .

Javob:  $13\sqrt{5}$ .

2-misol. Amallarni bajaring:  $(4\sqrt{12} + \frac{1}{2}\sqrt{18} - \sqrt{3}) : \sqrt{3}$ .

$$\begin{aligned} \text{Yechilishi: } & (4\sqrt{12} + \frac{1}{2}\sqrt{18} - \sqrt{3}) : \sqrt{3} = 4 \cdot \frac{\sqrt{12}}{\sqrt{3}} + \frac{\sqrt{18}}{2\sqrt{3}} - \frac{\sqrt{3}}{\sqrt{3}} = \\ & = 4 \cdot \sqrt{\frac{12}{3}} + \frac{1}{2} \cdot \sqrt{\frac{18}{3}} - 1 = 4\sqrt{4} + \frac{1}{2}\sqrt{6} - 1 = 7 + 0,5\sqrt{6}. \end{aligned}$$

Javob:  $7 + 0,5\sqrt{6}$ .

3-misol. Amallarni bajaring:  $(\frac{a}{b}\sqrt{ab} - 2\sqrt{\frac{b}{a}} - \sqrt{\frac{1}{ab}}) \cdot \sqrt{ab}$ .

$$\begin{aligned} \text{Yechilishi. } & (\frac{a}{b}\sqrt{ab} - 2\sqrt{\frac{b}{a}} - \sqrt{\frac{1}{ab}}) \cdot \sqrt{ab} = \frac{a}{b}\sqrt{ab}\sqrt{ab} - \\ & - 2\frac{\sqrt{b}}{\sqrt{a}} \cdot \sqrt{a}\sqrt{b} - \frac{1}{\sqrt{ab}} \cdot \sqrt{ab} = \frac{a}{b} \cdot ab - 2\sqrt{b^2} - 1 = a^2 - 2b - 1. \end{aligned}$$

Javob:  $a^2 - 2b - 1$ .

4-misol.  $\sqrt{5 - 2\sqrt{6}} - \sqrt{5 + 2\sqrt{6}}$  ni hisoblang.

Yechilishi. 1-usul.  $x = \sqrt{5 - 2\sqrt{6}} - \sqrt{5 + 2\sqrt{6}}$  ( $x < 0$ ) belgilash kiritamiz. U holda  $x^2 = 5 - 2\sqrt{6} - 2\sqrt{(5 - 2\sqrt{6})(5 + 2\sqrt{6})} + 5 + 2\sqrt{6} = 10 - 2\sqrt{25 - 24} = 8$ .

$x^2 = 8 \Leftrightarrow |x| = 2\sqrt{2} \Rightarrow x = \pm 2\sqrt{2}$ .  $x < 0$  ekanligini hisobga olsak,  $x = -2\sqrt{2}$ .

2-usul. Ildiz ostidagi ifodalarni to'la kvadrat shakliga keltiramiz:

$$\begin{aligned} \sqrt{5 - 2\sqrt{6}} - \sqrt{5 + 2\sqrt{6}} &= \sqrt{3 - 2\sqrt{3}\sqrt{2} + 2} - \sqrt{3 + 2\sqrt{3}\sqrt{2} + 2} = \\ &= \sqrt{(\sqrt{3} - \sqrt{2})^2} - \sqrt{(\sqrt{3} + \sqrt{2})^2} = |\sqrt{3} - \sqrt{2}| - |\sqrt{3} + \sqrt{2}| = \\ &= \sqrt{3} - \sqrt{2} - \sqrt{3} - \sqrt{2} = -2\sqrt{2}. \end{aligned}$$

Javob:  $-2\sqrt{2}$ .

5-misol.  $(2 - \sqrt{5})\sqrt{9 + 4\sqrt{5}}$  ni hisoblang.

$$\begin{aligned} \text{Yechilishi. } & (2 - \sqrt{5})\sqrt{9 + 4\sqrt{5}} = (2 - \sqrt{5})\sqrt{5 + 2\sqrt{5} \cdot \sqrt{4} + 4} = \\ &= (2 - \sqrt{5})\sqrt{(\sqrt{5} + \sqrt{4})^2} = (2 - \sqrt{5})(2 + \sqrt{5}) = 4 - 5 = -1. \end{aligned}$$

Javob:  $-1$ .

6-misol.  $\sqrt{y^2 - 10y + 25} + \sqrt{y^2 - 14y + 49}$  ifodani soddalash-tiring ( $y < 5$ ).

Yechilishi.  $\sqrt{y^2 - 10y + 25} + \sqrt{y^2 - 14y + 49} = \sqrt{(y - 5)^2} + \sqrt{(y - 7)^2} = |y - 5| + |y - 7|;$

$y < 5$  ekanligini hisobga olsak,  $|y - 5| + |y - 7| = 5 - y + 7 - y = 12 - 2y.$

J a v o b:  $12 - 2y.$

7-misol.  $\sqrt{(x - 9)^2} = x - 9$  tenglik  $x$  ning qanday qiymatlarida to'g'ri?

Yechilishi.  $\sqrt{(x - 9)^2} = |x - 9|$  bo'lganligi sababli berilgan tenglik

$$|x - 9| = x - 9$$

ko'rinishda yoziladi. Bu tenglik  $x - 9 \geq 0$  bo'lgandagina, ya'ni  $x \geq 9$  da to'g'ri.

J a v o b:  $x \in [9; +\infty).$

8-misol.  $\sqrt{1 + \sqrt{2 + \sqrt{x}}} = 2$  tenglamani yeching.

Yechilishi. Berilgan tenglama  $x > 0$  da o'rinli. Tenglamani

yechamiz:  $\sqrt{1 + \sqrt{2 + \sqrt{x}}} = 2 \Leftrightarrow 1 + \sqrt{2 + \sqrt{x}} = 4 \Leftrightarrow \sqrt{2 + \sqrt{x}} = 3 \Rightarrow \Rightarrow 2 + \sqrt{x} = 9 \Leftrightarrow \sqrt{x} = 7 \Leftrightarrow \{x = 49.$

J a v o b: 49.

9-misol.  $(x + 1 + \sqrt{3})(x + 1 - \sqrt{3})$  ifodani ko'phad shaklida yozing.

Yechilishi.  $(x + 1 + \sqrt{3})(x + 1 - \sqrt{3}) = = ((x + 1) + \sqrt{3})((x + 1) - \sqrt{3}) = x^2 + 2x + 1 - 3 = x^2 + 2x + 2;$

J a v o b:  $x^2 + 2x + 2.$

10-misol. Kasrni qisqartiring:  $\frac{x\sqrt{x} - y\sqrt{y}}{\sqrt{x} - \sqrt{y}}.$

Yechilishi.  $\frac{x\sqrt{x} - y\sqrt{y}}{\sqrt{x} - \sqrt{y}} = \frac{(\sqrt{x} - \sqrt{y})(x + \sqrt{xy} + \sqrt{y})}{\sqrt{x} - \sqrt{y}} = = x + \sqrt{xy} + y.$

Javob:  $x + \sqrt{xy} + y$ .

11-misol.  $\frac{5}{3+2\sqrt{2}} + \frac{5}{3-2\sqrt{2}}$  ifoda qiymatini toping.

$$\begin{aligned} \text{Yechilishi: } \frac{5}{3+2\sqrt{2}} + \frac{5}{3-2\sqrt{2}} &= \frac{5(3-2\sqrt{2}) + 5(3+2\sqrt{2})}{(3+2\sqrt{2})(3-2\sqrt{2})} = \\ &= \frac{15 - 10\sqrt{2} + 15 + 10\sqrt{2}}{3^2 - (2\sqrt{2})^2} = \frac{30}{9 - 8} = 30. \end{aligned}$$

Javob: 30.

Ayrim ifodalarni soddalashtirishda, qiymatlarini hisoblashda maxrajlarida ildizlar bo'lgan ba'zi kasrlar almashtirish yordamida maxrajlarida ildizlar bo'lmagan kasrlarga keltirilsa, soddalashtirish jarayoni ancha yengillashadi. **Kasr maxrajidagi ildizdan qutulish — kasr maxrajidagi irratsionallikdan qutilish deyiladi** (4.5-bandda bu masala batafsilroq bayon qilingan).

Kasr maxrajidagi irratsionallikdan qutilishga bir necha misollar ko'ramiz.

1-misol.  $\frac{3}{\sqrt{5}}$  kasrning maxrajidagi irratsionallikdan qutiling.

$$\text{Yechilishi. } \frac{3}{\sqrt{5}} = \frac{3\sqrt{5}}{\sqrt{5} \cdot \sqrt{5}} = \frac{3\sqrt{5}}{5}.$$

Javob:  $\frac{3\sqrt{5}}{5}$ .

2-misol.  $\frac{\sqrt{3}-\sqrt{2}}{\sqrt{3}+\sqrt{2}}$  kasrning maxrajidagi irratsionallikdan qutiling.

Yechilishi. Kasrning surat va maxrajini  $(\sqrt{3}-\sqrt{2})$  ga ko'paytiramiz ( $\sqrt{3}-\sqrt{2}$  va  $\sqrt{3}+\sqrt{2}$  ifodalar o'zaro qo'shma ifodalar deyiladi):

$$\begin{aligned} \frac{\sqrt{3}-\sqrt{2}}{\sqrt{3}+\sqrt{2}} &= \frac{(\sqrt{3}-\sqrt{2})(\sqrt{3}-\sqrt{2})}{(\sqrt{3}+\sqrt{2})(\sqrt{3}-\sqrt{2})} = \frac{(\sqrt{3})^2 - 2\sqrt{3} \cdot \sqrt{2} + (\sqrt{2})^2}{(\sqrt{3})^2 - (\sqrt{2})^2} = \\ &= \frac{3 - 2\sqrt{6} + 2}{3 - 2} = 5 - 2\sqrt{6}. \end{aligned}$$



Javob:  $5 - 2\sqrt{6}$ .

3-misol.  $\frac{4}{1+\sqrt{3}-\sqrt{2}}$  kasrning maxrajidagi irratsionallikdan qutiling.

Yechilishi. Avval kasrni surat va maxrajini  $(1 + \sqrt{3} + \sqrt{2})$  ga ko'paytirib,  $\sqrt{2}$  dan qutiramiz:

$$\begin{aligned} \frac{4(1+\sqrt{3}+\sqrt{2})}{((1+\sqrt{3})-\sqrt{2})((1+\sqrt{3})+\sqrt{2})} &= \frac{4(1+\sqrt{3}+\sqrt{2})}{1+2\sqrt{3}+3-2} = \frac{4(1+\sqrt{3}+\sqrt{2})}{2(1+\sqrt{3})} = \\ &= \frac{2(1+\sqrt{3}+\sqrt{2})}{1+\sqrt{3}}. \end{aligned}$$

Hosil bo'lgan kasrning surat va maxrajini  $(1 + \sqrt{3})$  ning qo'shasiga ko'paytiramiz:

$$\begin{aligned} \frac{2(1+\sqrt{3}+\sqrt{2})(1-\sqrt{3})}{(1+\sqrt{3})(1-\sqrt{3})} &= \frac{2(1-\sqrt{3}+\sqrt{3}-\sqrt{3}^2+\sqrt{2}-\sqrt{2}\cdot\sqrt{3})}{1-3} = \\ &= -(1-3+\sqrt{2}-\sqrt{6}) = 2 - \sqrt{2} + \sqrt{6}. \end{aligned}$$

Javob:  $2 - \sqrt{2} + \sqrt{6}$ .

4-misol.  $\frac{1}{2+\sqrt{5}} - \frac{1}{\sqrt{7}+3} + \frac{3}{1-\sqrt{7}} - \frac{10}{\sqrt{5}} + \sqrt{5}$  ifoda qiymatini hisoblang.

Yechilishi. Har bir kasrning maxrajini irratsionallikdan qutqarib berilgan ifoda qiymatini hisoblaymiz:

$$\begin{aligned} \frac{2-\sqrt{5}}{(2+\sqrt{5})(2-\sqrt{5})} - \frac{\sqrt{7}-3}{(\sqrt{7}+3)(\sqrt{7}-3)} + \frac{3(1+\sqrt{7})}{(1-\sqrt{7})(1+\sqrt{7})} - \frac{10\sqrt{5}}{(\sqrt{5})^2} + \sqrt{5} &= \\ = \frac{2-\sqrt{5}}{4-5} - \frac{\sqrt{7}-3}{7-9} + \frac{3(1+\sqrt{7})}{1-7} - \frac{10\sqrt{5}}{5} + \sqrt{5} &= \\ = -2 + \sqrt{5} + \frac{1}{2}\sqrt{7} - \frac{3}{2} - \frac{1}{2} - \frac{1}{2}\sqrt{7} - 2\sqrt{5} + \sqrt{5} &= -4. \end{aligned}$$

Javob:  $-4$ .

5-misol.  $\left(\frac{1}{\sqrt{a+1}+\sqrt{a}} + \frac{1}{\sqrt{a}-\sqrt{a-1}}\right) \cdot (\sqrt{a+1} - \sqrt{a-1})$  ni soddalashtiring.

**Yechilishi.** Ifodani soddalashtirishda undagi kasrlar maxrajlarini irratsionallikdan qutqaramiz:

$$\begin{aligned} & \left(\frac{1}{\sqrt{a+1}+\sqrt{a}} + \frac{1}{\sqrt{a}-\sqrt{a-1}}\right) \cdot (\sqrt{a+1} - \sqrt{a-1}) = \\ & = \left(\frac{\sqrt{a+1}-\sqrt{a}}{a+1-a} + \frac{\sqrt{a}+\sqrt{a-1}}{a-a+1}\right) \times (\sqrt{a+1} - \sqrt{a-1}) = (\sqrt{a+1} - \sqrt{a} + \\ & + \sqrt{a} + \sqrt{a-1})(\sqrt{a+1} - \sqrt{a-1}) = (\sqrt{a+1} + \sqrt{a-1})(\sqrt{a+1} - \\ & - \sqrt{a-1}) = a+1 - a+1 = 2. \end{aligned}$$

**Javob:** 2.

#### 4-§. Ratsional ko'rsatkichli daraja

**4.1. Haqiqiy  $a$  sonning  $n$ -darajali ildizi.**  $n \in \mathbb{N}$ ,  $n \geq 2$ ,  $a$  – ixtiyoriy haqiqiy son bo'lsin.

**Ta'rif.**  $a$  sonning  $n$ -darajali ildizi ( $\sqrt[n]{a}$  bilan belgilanadi) deb  $n$ -darajasi  $a$  ga teng bo'lgan  $b$  songa aytiladi.  $a$  – ildiz ostidagi son,  $n$  – ildiz ko'rsatkichi deyiladi.

Ta'rifga ko'ra  $\sqrt[n]{a} = b$  bo'lsa,  $a = b^n$ ,  $(\sqrt[n]{a})^n = a$ .

Masalan,  $\sqrt[3]{-8} = -2$ , chunki  $(-2)^3 = -8$ ;  $\sqrt[4]{81} = 3$ , chunki  $3^4 = 81$ .  $-3$  ham  $81$  ning to'rtinchi darajali ildizidir, chunki  $(-3)^4 = 81$ .

Ikkinchi darajali ildizni *kvadrat ildiz*, uchinchi darajali ildizni *kub ildiz* deb atashga odatlanilgan.  $\sqrt[n]{a}$  ifodada  $2$  sonini tushirib qoldirib,  $\sqrt{a}$  kabi yoziladi.

**Musbat sonning toq darajali faqat bitta ildizi mavjud. Bu ildiz musbat.**

**Musbat sonning juft darajali ikkita ildizi mavjud. Bu ildizlarning absolut miqdorlari teng bo'lib, ishoralari qarama-qarshidir.**

Misolalar: 1)  $\sqrt[3]{8} = 2$ , 2)  $\sqrt[5]{243} = 3$ ,  $\sqrt[4]{16} = \pm 2$ ,  $\sqrt[4]{625} = \pm 5$ .

**Manfiy sonning juft darajali ildizi mavjud emas.**

**Manfiy sonning toq darajali ildizi mavjud va faqat bitta. Bu ildiz manfiy.**

Misolalar: 1)  $\sqrt[6]{-128}$ ,  $\sqrt[4]{-81}$  – ma'noga ega emas.

2)  $\sqrt[3]{-27} = -3$ ;  $\sqrt[5]{-32} = -2$ .

3-misol.  $y = \sqrt[3]{3-x} + \sqrt[6]{5x-5}$  funksiya erkli o'zgaruvchi  $x$  ning qanday qiymatlarida aniqlangan?

Yechilishi: toq darajali ildiz ostidagi ifoda manfiy ham, nomanfiy ham bo'lishi mumkinligi sababli  $\sqrt[3]{3-x}$  ildiz o'zgaruvchi  $x$  ning har qanday qiymatida aniqlangan. Just darajali ildiz ostidagi ifoda faqat nomanfiy bo'lishi mumkinligi sababli  $\sqrt[6]{5x-5}$  ildiz o'zgaruvchi  $x \geq 1$  qiymatlardagina aniqlangan.

Javob:  $x \in [1; +\infty)$ .

**4.2.  $n$ -darajali arifmetik ildiz. Ta'rif.** Nomanfiy  $a$  ( $a \geq 0$ ) sonning  $n$ -darajali arifmetik ildizi deb  $n$ -darajasi ( $n \geq 2$ )  $a$  ga teng bo'lgan nomanfiy  $b$  ( $b \geq 0$ ) songa aytiladi ( $n \in \mathbb{N}$ ).

Masalan: 1)  $\sqrt[n]{a^n} = |a|$ ; 2)  $\sqrt[4]{(-3)^4} = |-3| = 3$ ;

3)  $\sqrt{9} = 3$  ( $\pm 3$  emas!); 4)  $\sqrt[4]{625} = 5$ ;

5)  $\sqrt{x^2+2x+1} + \sqrt{x^2-2x+1} = \sqrt{(x+1)^2} + \sqrt{(x-1)^2} = |x+1| + |x-1|$ ;

Bundan buyon  $\sqrt[2n]{a}$  ( $a \geq 0$ ) ifodadan  $a$  sonning  $2n$ -darajali arifmetik ildizini tushunamiz. Masalan,  $\sqrt[4]{81} = 3$ ,  $\sqrt{25} = 5$ ,  $\sqrt[6]{64} = 2$ .

**4.3.  $n$ -darajali arifmetik ildizning xossalari.**

1. Agar  $a \geq 0$ ;  $b \geq 0$  bo'lsa, u holda

$$\sqrt[n]{ab} = \sqrt[n]{a} \sqrt[n]{b}.$$

Agar  $a_1 \geq 0, a_2 \geq 0, \dots, a_k \geq 0$ , bo'lsa, u holda

$$\sqrt[n]{a_1 \cdot a_2 \cdot \dots \cdot a_k} = \sqrt[n]{a_1} \cdot \sqrt[n]{a_2} \cdot \dots \cdot \sqrt[n]{a_k}.$$

Masalan,  $\sqrt{3} \cdot \sqrt{8} \cdot \sqrt{6} = \sqrt{3 \cdot 8 \cdot 6} = \sqrt{144} = 12$ .

2. Agar  $a \geq 0, b > 0$  bo'lsa, u holda

$$\sqrt[n]{\frac{a}{b}} = \frac{\sqrt[n]{a}}{\sqrt[n]{b}}.$$

3. Agar  $a \geq 0, n \geq 2, k \geq 2, n \in \mathbb{N}, k \in \mathbb{N}$  bo'lsa, u holda

$$\sqrt[k]{\sqrt[n]{a}} = \sqrt[kn]{a}.$$

4. Agar  $a \geq 0, n \geq 2, k \geq 2, m \geq 2, n \in N, k \in N, m \in N$  bo'lsa, u holda

$$\sqrt[nk]{a^{mk}} = \sqrt[n]{a^m}.$$

5.  $\sqrt[n]{a} \cdot \sqrt[k]{a} = \sqrt[nk]{a^{n+k}}.$

6. Agar  $a > 0$  bo'lsa,

$$\sqrt[n]{a} : \sqrt[k]{a} = \sqrt[nk]{a^{n-k}}.$$

Masala, misollarni yechayotganda  $\sqrt[2n]{a^{2n}} = |a|, \sqrt[2n+1]{a^{2n+1}} = a$  tengliklarni yodda tutish zarur.

Misollar:

1)  $\sqrt[3]{\frac{5}{256}}$  soni  $\sqrt[3]{\frac{5}{32}}$  sonidan necha marta kichik?

Yechilishi:  $\sqrt[3]{\frac{5}{32}} : \sqrt[3]{\frac{5}{256}} = \frac{\sqrt[3]{5}}{\sqrt[3]{32}} \cdot \frac{\sqrt[3]{256}}{\sqrt[3]{5}} = \sqrt[3]{\frac{256}{32}} = \sqrt[3]{8} = 2.$

Javob: 2 marta.

2)  $(\sqrt[6]{16})^3 = \sqrt[6]{16^3} = \sqrt[6]{2^{12}} = 2^2 = 4.$     3)  $\sqrt[5]{\sqrt[3]{2}} = \sqrt[15]{2}.$

4)  $\sqrt[4]{(x-2)(8-x)} = \sqrt[4]{x-2} \sqrt[4]{8-x}$  tenglik  $x$  ning qanday qiymatlarida to'g'ri?

Yechilishi:

$$\begin{cases} x-2 \geq 0, \\ 8-x \geq 0 \end{cases} \Leftrightarrow \begin{cases} x \geq 2, \\ x \leq 8. \end{cases}$$

Javob:  $x \in [2; 8].$

5-misol.  $\left( \left( \sqrt[5]{a} \sqrt[5]{a} \right)^5 - \sqrt[5]{a} \right) : \sqrt[10]{a^2}$  ifodani soddalashtiring.

Yechilishi: Berilgan ifodani soddalashtirishda arifmetik ildizning 3- va 4- xossalariidan foydalanamiz:

$$\begin{aligned} & \left( \left( \sqrt[5]{a} \sqrt[5]{a} \right)^5 - \sqrt[5]{a} \right) : \sqrt[10]{a^2} = \left( \left( \sqrt[5]{a} \cdot \sqrt[5]{a} \right)^5 - \sqrt[5]{a} \right) : \sqrt[5]{a^2} = \\ & = \left( a \cdot \sqrt[5]{a} - \sqrt[5]{a} \right) : \sqrt[5]{a} = (a-1) \sqrt[5]{a} \cdot \frac{1}{\sqrt[5]{a}} = a-1. \end{aligned}$$

Javob:  $a-1.$

6-misol.  $\left( \frac{a+b}{\sqrt[3]{a} + \sqrt[3]{b}} - \sqrt[3]{ab} \right) : \left( \sqrt[3]{a} - \sqrt[3]{b} \right)^2$  ifodani soddalashtiring.

$$\begin{aligned}
 \text{Yechilishi: } & \left( \frac{a+b}{\sqrt[3]{a} + \sqrt[3]{b}} - \sqrt[3]{ab} \right) : (\sqrt[3]{a} - \sqrt[3]{b})^2 = \\
 & = \left( \frac{(\sqrt[3]{a} + \sqrt[3]{b}) \left( \sqrt[3]{a^2} - \sqrt[3]{ab} + \sqrt[3]{b^2} \right) - \sqrt[3]{ab}}{\sqrt[3]{a} + \sqrt[3]{b}} : (\sqrt[3]{a} - \sqrt[3]{b})^2 = \right. \\
 & = \left( \sqrt[3]{a^2} - \sqrt[3]{ab} + \sqrt[3]{b^2} - \sqrt[3]{ab} \right) : (\sqrt[3]{a} - \sqrt[3]{b})^2 = \\
 & = \left( \sqrt[3]{a^2} - 2\sqrt[3]{a}\sqrt[3]{b} + \sqrt[3]{b^2} \right) : (\sqrt[3]{a} - \sqrt[3]{b})^2 = (\sqrt[3]{a} - \sqrt[3]{b})^2 : (\sqrt[3]{a} - \sqrt[3]{b})^2 = 1.
 \end{aligned}$$

Javob: 1.

6-misol.  $b > a > 0$  bo'lsa.

$$\sqrt{\frac{a\sqrt{a} - b\sqrt{b}}{\sqrt{a} - \sqrt{b}} + \sqrt{ab}} - \sqrt{\frac{a\sqrt{a} + b\sqrt{b}}{\sqrt{a} + \sqrt{b}} - \sqrt{ab}}$$

ifodani soddalashtiring.

$$\begin{aligned}
 \text{Yechilishi: } & \sqrt{\frac{a\sqrt{a} - b\sqrt{b}}{\sqrt{a} - \sqrt{b}} + \sqrt{ab}} - \sqrt{\frac{a\sqrt{a} + b\sqrt{b}}{\sqrt{a} + \sqrt{b}} - \sqrt{ab}} = \\
 & = \sqrt{\frac{(\sqrt{a})^3 - (\sqrt{b})^3}{\sqrt{a} - \sqrt{b}} + \sqrt{ab}} - \sqrt{\frac{(\sqrt{a})^3 + (\sqrt{b})^3}{\sqrt{a} + \sqrt{b}} - \sqrt{ab}} = \\
 & = \sqrt{\frac{(\sqrt{a} - \sqrt{b}) \left( (\sqrt{a})^2 + \sqrt{a}\sqrt{b} + (\sqrt{b})^2 \right)}{\sqrt{a} - \sqrt{b}} + \sqrt{ab}} - \\
 & - \sqrt{\frac{(\sqrt{a} + \sqrt{b}) \left( (\sqrt{a})^2 - \sqrt{a}\sqrt{b} + (\sqrt{b})^2 \right)}{\sqrt{a} + \sqrt{b}} - \sqrt{ab}} = \\
 & = \sqrt{(\sqrt{a})^2 + 2\sqrt{a}\sqrt{b} + (\sqrt{b})^2} - \sqrt{(\sqrt{a})^2 - 2\sqrt{a}\sqrt{b} + (\sqrt{b})^2} = \\
 & = \sqrt{(\sqrt{a} + \sqrt{b})^2} - \sqrt{(\sqrt{a} - \sqrt{b})^2} = |\sqrt{a} + \sqrt{b}| - |\sqrt{a} - \sqrt{b}| = \\
 & = \sqrt{a} + \sqrt{b} - \sqrt{b} + \sqrt{a} = 2\sqrt{a}. \\
 \text{Javob: } & 2\sqrt{a}.
 \end{aligned}$$

**4.4. Ratsional ko'rsatkichli daraja.** Arifmetik ildizning ta'rifi va xossalriga asoslanib, agar  $n$  – natural son ( $n \in \mathbb{N}$ ),  $k$  – butun son ( $k \in \mathbb{Z}$ ) va  $k$  son  $p$  ga bo'linsa,  $a > 0$  bo'lganda

$$\sqrt[n]{a^k} = a^{\frac{k}{n}}$$

tenglik to'g'ri ekanligiga ishonch hosil qilish mumkin. Masalan,

$$\sqrt[7]{5^{21}} = \sqrt[7]{(5^3)^7} = 5^3 = 125 \text{ yoki } \sqrt[7]{5^{21}} = 5^{\frac{21}{7}} = 5^3 = 125.$$

Bordi-yu, agar  $\frac{k}{n}$  nisbat butun son bo'lmasa, u holda  $a^{\frac{k}{n}}$  ( $a > 0$ ,  $n \in \mathbb{N}$ ,  $k \in \mathbb{Z}$ ) daraja

$$\sqrt[n]{a^k} = a^{\frac{k}{n}}$$

formula to'g'riligicha qoladigan qilib ta'riflanadi, ya'ni

$$a^{\frac{k}{n}} = \sqrt[n]{a^k} \quad (1)$$

deb hisoblanadi. Shunday qilib, (1) formula istalgan butun  $k$  va natural  $n \geq 2$  va  $a > 0$  uchun to'g'ri bo'ladi.

Masalan,

$$0,7^{\frac{13}{6}} = \sqrt[6]{(0,7)^{13}} \cdot \left(\frac{1}{3}\right)^{1,3} = \left(\frac{1}{3}\right)^{1,3} = \sqrt[10]{\left(\frac{1}{3}\right)^{13}} \cdot 5^{-\frac{1}{6}} = 5^{-\frac{1}{6}} = \sqrt[6]{5^{-1}}.$$

**Asosi nolga teng bo'lgan daraja faqat musbat kasr ko'rsatkich uchun aniqlangan:** agar  $\frac{k}{n}$  – musbat kasr son bo'lsa ( $n \in \mathbb{N}$ ,  $k \in \mathbb{N}$ ), u holda

$$0^{\frac{k}{n}} = 0.$$

$(-2)^{\frac{3}{4}}$ ,  $(-8)^{-\frac{1}{8}}$ ,  $0^{-\frac{1}{2}}$  kabi ifodalar ma'noga ega emas. Agar  $a > 0$ ,  $k$  – butun,  $m$  va  $n$  natural sonlar bo'lsa, u holda (1) formuladan

$$a^{\frac{km}{nm}} = \sqrt[nm]{a^{km}} = a^{\frac{k}{n}}.$$

Shunday qilib, ratsional ko'rsatkichli darajani ildiz shaklida va aksincha, ildizni ratsional ko'rsatkichli daraja shaklida tasvirlash mumkin.

**Natural ko'rsatkichli darajaning barcha xossalari (III bob, 1.2-band) istalgan ratsional ko'rsatkichli va musbat asosli darajalar uchun to'g'ridir.**

Agar  $a > 0$ ,  $p$  va  $q$  – ixtiyoriy ratsional sonlar bo'lsa:

$$1. a^p \cdot a^q = a^{p+q}, \quad 2. a^p : a^q = a^{p-q}, \quad 3. (a^p)^q = a^{pq}.$$

Agar  $a > 0$ ,  $b > 0$ ,  $p$  – ixtiyoriy ratsional son bo'lsa:

$$4. (a \cdot b)^p = a^p b^p. \quad 5. \left(\frac{a}{b}\right)^p = \frac{a^p}{b^p}.$$

Ratsional ko'rsatkichli darajaning xossalarini qo'llanilishiga doir misollar keltiramiz:

1-misol.  $(0,04)^{-1,5} - (0,125)^{-\frac{2}{3}}$  ni hisoblang.

$$\begin{aligned} \text{Yechilishi. } & (0,04)^{-1,5} - (0,125)^{-\frac{2}{3}} = (0,04)^{-\frac{3}{2}} - (0,125)^{-\frac{2}{3}} = \\ & = \sqrt{(0,04)^{-3}} - \sqrt[3]{(0,125)^{-2}} = \sqrt{\left((0,2)^2\right)^{-3}} - \sqrt[3]{\left((0,5)^3\right)^{-2}} = \\ & = \sqrt{(0,2)^{-6}} - \sqrt[3]{(0,5)^{-6}} = (0,2)^{-\frac{6}{2}} - (0,5)^{-\frac{6}{3}} = (0,2)^{-3} - (0,5)^{-2} = \\ & = \left(\frac{1}{5}\right)^{-3} - \left(\frac{1}{2}\right)^{-2} = 125 - 4 = 121. \end{aligned}$$

Javob: 121.

2-misol.  $x = 27$  bo'lsa,  $\sqrt{x} : \sqrt[6]{x}$  ning qiymatini toping.

$$\text{Yechilishi: } \sqrt{x} : \sqrt[6]{x} = x^{\frac{1}{2}} : x^{\frac{1}{6}} = x^{\frac{1}{2} - \frac{1}{6}} = x^{\frac{1}{3}} = \sqrt[3]{x}.$$

$x$  ning qiymatini qo'ysak.  $\sqrt[3]{27} = \sqrt[3]{3^3} = 3^{\frac{3}{3}} = 3.$

Javob: 3.

3-misol.  $\sqrt[3]{\sqrt[4]{\frac{1}{4096}}} - \sqrt[4]{\sqrt[3]{4096}}$  ifodaning qiymatini toping.

$$\begin{aligned} \text{Yechilishi: } & \sqrt[3]{\sqrt[4]{\frac{1}{4096}}} - \sqrt[4]{\sqrt[3]{4096}} = \left(\left(\frac{1}{64^2}\right)^4\right)^{\frac{1}{3}} - \left(\left((64)^2\right)^3\right)^{\frac{1}{4}} = \\ & = \left(\frac{1}{64}\right)^{\frac{2 \cdot 1 \cdot 1}{4 \cdot 3}} - 64^{\frac{2 \cdot 1 \cdot 1}{4 \cdot 3}} = \left(\frac{1}{2}\right)^{\frac{6 \cdot 1}{6}} - 2^{\frac{6 \cdot 1}{6}} = \frac{1}{2} - 2 = -1\frac{1}{2}. \end{aligned}$$

Javob:  $-1\frac{1}{2}.$

4-misol.  $\sqrt[3]{\frac{x-2}{|x|-2}}$  ifoda  $x$  ning qanday qiymatlarida aniqlangan?

Yechilishi. O'zgaruvchi  $x$  ildiz ostidagi kasr ifodaning maxrajini nolga aylantiradigan qiymatlardan tashqari barcha qiymatlarni qabul qilishi mumkin:

$$|x| - 2 \neq 0 \Leftrightarrow |x| \neq 2 \Rightarrow [x \neq \pm 2.$$

$$\text{Javob: } x \in (-\infty; -2) \cup (-2; 2) \cup (2; +\infty)$$

$$\text{5-misol. } \frac{x^2 - x^{\frac{1}{3}} \cdot y^{\frac{1}{3}} + y^2}{x+y} \text{ kasrni qisqartiring.}$$

$$\text{Yechilishi. } \frac{x^2 - x^{\frac{1}{3}} \cdot y^{\frac{1}{3}} + y^2}{x+y} = \frac{\left(x^{\frac{1}{3}}\right)^2 - x^{\frac{1}{3}} \cdot y^{\frac{1}{3}} + \left(y^{\frac{1}{3}}\right)^2}{\left(x^{\frac{1}{3}}\right)^3 + \left(y^{\frac{1}{3}}\right)^3} =$$

$$= \frac{\left(x^{\frac{1}{3}}\right)^2 - x^{\frac{1}{3}} \cdot y^{\frac{1}{3}} + \left(y^{\frac{1}{3}}\right)^2}{\left(x^{\frac{1}{3}} + y^{\frac{1}{3}}\right) \left[\left(x^{\frac{1}{3}}\right)^2 - x^{\frac{1}{3}} \cdot y^{\frac{1}{3}} + \left(y^{\frac{1}{3}}\right)^2\right]} = \frac{1}{\sqrt[3]{x} + \sqrt[3]{y}}.$$

$$\text{Javob: } \frac{1}{\sqrt[3]{x} + \sqrt[3]{y}}.$$

$$\text{6-misol. } \sqrt{936} + \sqrt{601} + \sqrt{576} \text{ ni hisoblang.}$$

$$\begin{aligned} \text{Yechilishi: } & \sqrt{936} + \sqrt{601} + \sqrt{576} = \sqrt{936} + \sqrt{601} + \sqrt{24^2} = \\ & = \sqrt{936} + \sqrt{601} + 24 = \sqrt{936} + \sqrt{625} = \sqrt{936} + \sqrt{25^2} = \sqrt{936} + 25 = \\ & = \sqrt{961} = \sqrt{31^2} = 31. \end{aligned}$$

$$\text{Javob: } 31.$$

$$\text{7-misol. } \frac{\sqrt[7]{128} \cdot \sqrt[5]{32}}{\sqrt{81} \cdot \sqrt[3]{64}} \text{ ni hisoblang.}$$

$$\text{Yechilishi. } \frac{\sqrt[7]{128} \cdot \sqrt[5]{32}}{\sqrt{81} \cdot \sqrt[3]{64}} = \frac{\sqrt[7]{2^7} \cdot \sqrt[5]{2^5}}{\sqrt{9^2} \cdot \sqrt[3]{4^3}} = \frac{2 \cdot 2}{9 \cdot 4} = \frac{1}{9}.$$

$$\text{Javob: } \frac{1}{9}.$$

$$\text{8-misol. } \left(\sqrt[3]{10\sqrt{-729}} + 5\sqrt[3]{-343} - 5\right)^3 \text{ ni hisoblang.}$$



$$\begin{aligned}
 & \text{Yechilishi. } \left( \sqrt[3]{10\sqrt{-729}} + 5\sqrt[3]{-343} - 5 \right)^3 = \\
 & = \left( \sqrt[3]{10(-\sqrt[3]{729})} + (-5\sqrt[3]{343}) - 5 \right)^3 = \left( \sqrt[3]{-10 \cdot \sqrt[3]{9^3}} - 5\sqrt[3]{7^3} - 5 \right)^3 = \\
 & = \left( \sqrt[3]{-10 \cdot 9} - 5 \cdot 7 - 5 \right)^3 = \left( \sqrt[3]{-90 - 35} - 5 \right)^3 = \left( \sqrt[3]{-125} - 5 \right)^3 = \\
 & = \left( -\sqrt[3]{125} - 5 \right)^3 = (-5 - 5)^3 = (-10)^3 = -1000.
 \end{aligned}$$

Javob: -1000.

9-misol.  $\sqrt[3]{2 - \sqrt{3}} \cdot \sqrt[6]{7 + 4\sqrt{3}}$  ko'paytma qiymatini toping.

$$\begin{aligned}
 & \text{Yechilishi: } \sqrt[3]{2 - \sqrt{3}} \cdot \sqrt[6]{7 + 4\sqrt{3}} = \sqrt[3]{2 - \sqrt{3}} \cdot \sqrt[6]{4 + 2\sqrt{4}\sqrt{3} + 3} = \\
 & = \sqrt[3]{2 - \sqrt{3}} \cdot \sqrt{\left( \sqrt{4} + \sqrt{3} \right)^2} = \sqrt[3]{2 - \sqrt{3}} \cdot \sqrt{2 + \sqrt{3}} = \sqrt[3]{\left( 2 - \sqrt{3} \right) \left( 2 + \sqrt{3} \right)} = \\
 & = \sqrt[3]{4 - 3} = 1.
 \end{aligned}$$

Javob: 1.

Ba'zi hollarda irratsional ifodalarni soddalashtirishda

$\sqrt{A \pm \sqrt{B}} = \sqrt{\frac{A + \sqrt{A^2 - B}}{2}} \pm \sqrt{\frac{A - \sqrt{A^2 - B}}{2}}$  ( $A \geq \sqrt{B}$ ) ayniyatdan foydalanish mumkin.

10-misol.  $\sqrt{7 + \sqrt{48}}$  ni soddalashtiring.

$$\begin{aligned}
 & \text{Yechilishi. } \sqrt{7 + \sqrt{48}} = \sqrt{\frac{7 + \sqrt{49 - 48}}{2}} + \sqrt{\frac{7 - \sqrt{49 - 48}}{2}} = \\
 & = \sqrt{\frac{7+1}{2}} + \sqrt{\frac{7-1}{2}} = 2 + \sqrt{3}.
 \end{aligned}$$

Javob:  $2 + \sqrt{3}$ .

11-misol.  $\sqrt{10 - 2\sqrt{9 + 4\sqrt{5}}}$  ni soddalashtiring.

Yechilishi. Oldin  $\sqrt{9 + 4\sqrt{5}} = \sqrt{9 + \sqrt{80}}$  ni soddalashtiramiz.

$$\begin{aligned}
 & \sqrt{9 + \sqrt{80}} = \sqrt{\frac{9 + \sqrt{81 - 80}}{2}} + \sqrt{\frac{9 - \sqrt{81 - 80}}{2}} = \sqrt{5} + 2; \\
 & \sqrt{10 - 2(\sqrt{5} + 2)} = \sqrt{6 - 2\sqrt{5}} = \sqrt{6 - \sqrt{20}} = \sqrt{\frac{6 + \sqrt{36 - 20}}{2}} -
 \end{aligned}$$

$$-\sqrt{\frac{6 - \sqrt{36 - 20}}{2}} = \sqrt{5} - 1.$$

Javob:  $\sqrt{5} - 1$ .

12-misol.  $\frac{a + \sqrt{2 + \sqrt{5}} \cdot \sqrt[12]{(9 - 4\sqrt{5})^3}}{\sqrt[3]{2 - \sqrt{5}} \cdot \sqrt[6]{9 + 4\sqrt{5}} + \sqrt[3]{a^2} - \sqrt[3]{a}}$  ni soddalashtiring.

Yechilishi.

$$\begin{aligned} & \frac{a + \sqrt{2 + \sqrt{5}} \cdot \sqrt[12]{(9 - 4\sqrt{5})^3}}{\sqrt[3]{2 - \sqrt{5}} \cdot \sqrt[6]{9 + 4\sqrt{5}} + \sqrt[3]{a^2} - \sqrt[3]{a}} = \frac{a + \sqrt[4]{(2 + \sqrt{5})^2} \cdot \sqrt[4]{9 - 4\sqrt{5}}}{\sqrt[6]{(2 - \sqrt{5})^2} \cdot \sqrt[6]{9 + 4\sqrt{5}} + \sqrt[3]{a^2} - \sqrt[3]{a}} = \\ & = \frac{a + \sqrt[4]{9 + 4\sqrt{5}} \sqrt[4]{9 - 4\sqrt{5}}}{\sqrt[6]{9 - 4\sqrt{5}} \cdot \sqrt[6]{9 + 4\sqrt{5}} + \sqrt[3]{a^2} - \sqrt[3]{a}} = \frac{a + \sqrt[4]{81 - 80}}{\sqrt[6]{81 - 80} + \sqrt[3]{a^2} - \sqrt[3]{a}} = \\ & = \frac{a + 1}{1 - \sqrt[3]{a} + \sqrt[3]{a^2}} = \frac{\left( \sqrt[3]{a} + 1 \right) \left( \sqrt[3]{a^2} - \sqrt[3]{a} + 1 \right)}{1 - \sqrt[3]{a} + \sqrt[3]{a^2}} = \sqrt[3]{a} + 1. \end{aligned}$$

Javob:  $\sqrt[3]{a} + 1$ .

13-misol.

$(\sqrt{3 - \sqrt{2 - \sqrt{24}}} \cdot \sqrt{3 + \sqrt{2 - \sqrt{24}}}) \cdot \sqrt{3 - \sqrt{2 + \sqrt{24}}} \cdot \sqrt{3 + \sqrt{2 + \sqrt{24}}}$   
ni soddalashtiring:

Yechilishi.

$$\begin{aligned} & (\sqrt{3 - \sqrt{2 - \sqrt{24}}} \cdot \sqrt{3 + \sqrt{2 - \sqrt{24}}}) \cdot \sqrt{3 - \sqrt{2 + \sqrt{24}}} \cdot \sqrt{3 + \sqrt{2 + \sqrt{24}}} = \\ & = \sqrt{9 - (2 - \sqrt{24})} \cdot \sqrt{9 - (2 + \sqrt{24})} \cdot \sqrt{(7 + \sqrt{24})} \cdot \sqrt{(7 - \sqrt{24})} = \\ & = \sqrt{49 - 24} = \sqrt{25} = 5. \end{aligned}$$

Javob: 5.

14-misol.  $\frac{x^{\frac{3}{4}} - 25x^{\frac{1}{4}}}{x^2 + 5x^{\frac{1}{4}}}$  kasrni qisqartiring.

Yechilishi: 
$$\frac{x^{\frac{3}{4}} - 25x^{\frac{1}{4}}}{x^{\frac{1}{2}} + 5x^{\frac{1}{4}}} = \frac{x^{\frac{1}{4}}(x^{\frac{1}{2}} - 25)}{x^{\frac{1}{4}}(x^{\frac{1}{4}} + 5)} = \frac{(x^{\frac{1}{4}} - 5)(x^{\frac{1}{4}} + 5)}{x^{\frac{1}{4}} + 5} = \sqrt[4]{x} - 5.$$

Javob:  $\sqrt[4]{x} - 5.$

15-misol.  $\sqrt[3]{x} - 2\sqrt[6]{x} = 0$  tenglamani yeching.

Yechilishi: Berilgan tenglama  $x \geq 0$  da aniqlangan.

$$\sqrt[3]{x} - 2\sqrt[6]{x} = 0 \Leftrightarrow \sqrt[6]{x}(\sqrt[6]{x} - 2) = 0 \Leftrightarrow$$

$$\Leftrightarrow \begin{cases} \sqrt[6]{x} = 0, \\ \sqrt[6]{x} - 2 = 0 \end{cases} \Rightarrow \begin{cases} x = 0, \\ x = 64. \end{cases}$$

Javob: 0; 64.

16-misol.  $\left( \frac{(\sqrt[4]{a^3} + \sqrt[4]{b^3})(\sqrt[4]{a^3} - \sqrt[4]{b^3})}{\sqrt{a} - \sqrt{b}} - \sqrt{ab} \right) : \frac{a+b}{2}$  ifodani

soddalashtiring.

Yechilishi:  $a \geq 0; b \geq 0; a \neq b$  shartlarda ifodani sodda-

lashtiramiz: 
$$\left( \frac{(\sqrt[4]{a^3} + \sqrt[4]{b^3})(\sqrt[4]{a^3} - \sqrt[4]{b^3})}{\sqrt{a} - \sqrt{b}} - \sqrt{ab} \right) : \frac{a+b}{2} =$$

$$= \left( \frac{\sqrt{a^3} - \sqrt{b^3}}{\sqrt{a} - \sqrt{b}} - \sqrt{ab} \right) \cdot \frac{2}{a+b} = \left( \frac{\left(a^{\frac{1}{2}}\right)^3 - \left(b^{\frac{1}{2}}\right)^3}{a^{\frac{1}{2}} - b^{\frac{1}{2}}} - (ab)^{\frac{1}{2}} \right) \cdot \frac{2}{a+b} =$$

$$= \left( \frac{\left(a^{\frac{1}{2}} - b^{\frac{1}{2}}\right)\left(a + a^{\frac{1}{2}}b^{\frac{1}{2}} + b\right)}{a^{\frac{1}{2}} - b^{\frac{1}{2}}} - a^{\frac{1}{2}}b^{\frac{1}{2}} \right) \cdot \frac{2}{a+b} =$$

$$= \left( a + a^{\frac{1}{2}}b^{\frac{1}{2}} + b - a^{\frac{1}{2}}b^{\frac{1}{2}} \right) \cdot \frac{2}{a+b} = (a+b) \cdot \frac{2}{a+b} = 2.$$

Javob: 2.

17-misol.  $\frac{\left(a^{\frac{1}{3}} + b^{\frac{1}{3}}\right)\left(a^{\frac{1}{6}}b^{-\frac{1}{3}} + a^{-\frac{1}{3}}b^{\frac{1}{6}}\right)^2}{a^{-1} + b^{-1} - \left(a^{-\frac{2}{3}} - b^{-\frac{2}{3}}\right)\left(a^{-\frac{1}{3}} - b^{-\frac{1}{3}}\right)} - 2a^{\frac{1}{2}}b^{\frac{1}{2}}$  ifodani

soddalashtiring, bunda  $a > 0; b > 0$ .

Yechilishi:  $\frac{\left(a^{\frac{1}{3}} + b^{\frac{1}{3}}\right)\left(a^{\frac{1}{6}}b^{-\frac{1}{3}} + a^{-\frac{1}{3}}b^{\frac{1}{6}}\right)^2}{a^{-1} + b^{-1} - \left(a^{-\frac{2}{3}} - b^{-\frac{2}{3}}\right)\left(a^{-\frac{1}{3}} - b^{-\frac{1}{3}}\right)} - 2a^{\frac{1}{2}}b^{\frac{1}{2}} =$

$$= \frac{\left(a^{\frac{1}{3}} + b^{\frac{1}{3}}\right) \cdot \left(a^{\frac{1}{6}}b^{\frac{1}{6}}\left(a^{-\frac{1}{2}} + b^{-\frac{1}{2}}\right)\right)^2}{\frac{1}{a} + \frac{1}{b} - \left(\frac{1}{a^{\frac{2}{3}}} - \frac{1}{b^{\frac{2}{3}}}\right)\left(\frac{1}{a^{\frac{1}{3}}} - \frac{1}{b^{\frac{1}{3}}}\right)} - 2a^{\frac{1}{2}}b^{\frac{1}{2}} =$$

$$= \frac{a^{\frac{1}{3}}b^{\frac{1}{3}}\left(a^{\frac{1}{3}} + b^{\frac{1}{3}}\right)\left(\frac{a^{\frac{1}{2}} + b^{\frac{1}{2}}}{a^{\frac{1}{2}}b^{\frac{1}{2}}}\right)^2}{\frac{1}{a} + \frac{1}{b} - \frac{a^{\frac{2}{3}} - b^{\frac{2}{3}}}{a^{\frac{2}{3}}b^{\frac{2}{3}}}\frac{a^{\frac{1}{3}} - b^{\frac{1}{3}}}{a^{\frac{1}{3}}b^{\frac{1}{3}}}} - 2a^{\frac{1}{2}}b^{\frac{1}{2}} = \frac{(ab)^{\frac{1}{3}}\left(a^{\frac{1}{3}} + b^{\frac{1}{3}}\right)\frac{\left(a^{\frac{1}{2}} + b^{\frac{1}{2}}\right)^2}{ab}}{a + b - \frac{a^{\frac{2}{3}} - b^{\frac{2}{3}}}{ab}\frac{a^{\frac{1}{3}} - b^{\frac{1}{3}}}{ab}} - 2a^{\frac{1}{2}}b^{\frac{1}{2}} =$$

$$- 2a^{\frac{1}{2}}b^{\frac{1}{2}} = \frac{(ab)^{\frac{1}{3}}\left(a^{\frac{1}{3}} + b^{\frac{1}{3}}\right)\left(a + 2a^{\frac{1}{2}}b^{\frac{1}{2}} + b\right)}{(ab)^{\frac{1}{3}}\left(a^{\frac{1}{3}} + b^{\frac{1}{3}}\right)} - 2a^{\frac{1}{2}}b^{\frac{1}{2}} =$$

$$= a + 2a^{\frac{1}{2}}b^{\frac{1}{2}} + b - 2a^{\frac{1}{2}}b^{\frac{1}{2}} = a + b.$$

Javob:  $a + b$ .

**4.5. Ratsional ko'rsatkichli kasr ifodalar maxrajidagi irratsionallikdan qutilish.** Quyida ayrim kasr ifodalar maxrajidagi irratsionallikdan qutilish usullarini keltiramiz.

1.  $\frac{a}{\sqrt{b}}$  kasrning surat va maxrajini  $\sqrt{b}$  ga ko'paytiriladi:

$$\frac{a}{\sqrt{b}} = \frac{a\sqrt{b}}{\sqrt{b} \cdot \sqrt{b}} = \frac{a\sqrt{b}}{b};$$

$\frac{a}{\sqrt[3]{b}}$  kasrning surat va maxrajini  $\sqrt[3]{b^2}$  ga ko'paytiriladi:

$$\frac{a}{\sqrt[3]{b}} = \frac{a \sqrt[3]{b^2}}{\sqrt[3]{b} \cdot \sqrt[3]{b^2}} = \frac{a \sqrt[3]{b^2}}{\sqrt[3]{b^3}} = \frac{a \sqrt[3]{b^2}}{b};$$

$\frac{a}{\sqrt[3]{b^2}}$  kasrning surat va maxrajini  $\sqrt[3]{b}$  ga ko'paytiriladi:

$$\frac{a}{\sqrt[3]{b^2}} = \frac{a \sqrt[3]{b}}{\sqrt[3]{b^2} \cdot \sqrt[3]{b}} = \frac{a \sqrt[3]{b}}{\sqrt[3]{b^3}} = \frac{a \sqrt[3]{b}}{b}.$$

$\frac{a}{\sqrt[n]{b^k}}$  ( $n > 3; 1 \leq k < n$ ) ko'rinishidagi kasrlar maxrajidagi irratsionallikdan ham shu tarzda qutilinadi.

2.  $\frac{c}{\sqrt{a} \pm \sqrt{b}}$  kasrning surat va maxraji maxrajning qo'shmasiga ko'paytiriladi:

$$\frac{c}{\sqrt{a} \pm \sqrt{b}} = \frac{c(\sqrt{a} \mp \sqrt{b})}{(\sqrt{a} \pm \sqrt{b})(\sqrt{a} \mp \sqrt{b})} = \frac{c(\sqrt{a} \mp \sqrt{b})}{a - b}.$$

3.  $\frac{c}{\sqrt[3]{a} \pm \sqrt[3]{b}}$  kasrning surat va maxraji  $(\sqrt[3]{a^2} \mp \sqrt[3]{ab} + \sqrt[3]{b^2})$  ga ko'paytiriladi:

$$\frac{c}{\sqrt[3]{a} \pm \sqrt[3]{b}} = \frac{c(\sqrt[3]{a^2} \mp \sqrt[3]{ab} + \sqrt[3]{b^2})}{(\sqrt[3]{a} \pm \sqrt[3]{b})(\sqrt[3]{a^2} \mp \sqrt[3]{ab} + \sqrt[3]{b^2})} = \frac{c(\sqrt[3]{a^2} \mp \sqrt[3]{ab} + \sqrt[3]{b^2})}{a \pm b}.$$

4.  $\frac{c}{\sqrt[3]{a^2} \pm \sqrt[3]{ab} + \sqrt[3]{b^2}}$  kasrning surat va maxrajini  $(\sqrt[3]{a} \mp \sqrt[3]{b})$  ga ko'paytiriladi:

$$\frac{c}{\sqrt[3]{a^2} \pm \sqrt[3]{ab} + \sqrt[3]{b^2}} = \frac{c(\sqrt[3]{a} \mp \sqrt[3]{b})}{(\sqrt[3]{a^2} \pm \sqrt[3]{ab} + \sqrt[3]{b^2})(\sqrt[3]{a} \mp \sqrt[3]{b})} = \frac{c(\sqrt[3]{a} \mp \sqrt[3]{b})}{a \mp b}.$$

M i s o l.  $\frac{4}{\sqrt[3]{25} - \sqrt[3]{9}}$  kasr maxrajini irratsionallikdan qutqaring.

Y e c h i l i s h i: 
$$\frac{4}{\sqrt[3]{25} - \sqrt[3]{9}} = \frac{4(\sqrt[3]{25^2} + \sqrt[3]{25 \cdot 9} + \sqrt[3]{9^2})}{(\sqrt[3]{25} - \sqrt[3]{9})(\sqrt[3]{25^2} + \sqrt[3]{25 \cdot 9} + \sqrt[3]{9^2})} =$$

$$= \frac{4(\sqrt[3]{625} + \sqrt[3]{225} + \sqrt[3]{81})}{(\sqrt[3]{25})^3 - (\sqrt[3]{9})^3} = \frac{4(5\sqrt[3]{5} + \sqrt[3]{225} + 3\sqrt[3]{3})}{16} = \frac{5\sqrt[3]{5} + \sqrt[3]{225} + 3\sqrt[3]{3}}{4}$$

J a v o b:  $\frac{5\sqrt[3]{5} + \sqrt[3]{225} + 3\sqrt[3]{3}}{4}$ .

### Mustaqil ishlash uchun test topshiriqlari

1.  $0.5\sqrt{98} + 4\sqrt{18} - \frac{1}{5}\sqrt{50} - \frac{1}{3}\sqrt{72} + \sqrt{200}$  ifodani soddalashtiring.

A)  $24,5\sqrt{2}$ ; B)  $31,5\sqrt{2}$ ; C)  $22,5\sqrt{2}$ ; D) 20,5; E) 25,5.

2.  $\left(\frac{m}{n}\sqrt{\frac{1}{mn}} - \frac{m}{n}\sqrt{\frac{m}{n}} - n\sqrt{\frac{n}{m}}\right) \cdot \sqrt{mn}$  ni soddalashtiring.

A)  $\frac{m(1-m)-n^3}{n}$ ; B)  $\frac{1-m}{mn}$ ; C)  $\frac{1}{m} - \frac{1}{n}$ ; D)  $\frac{1-m-n}{mn}$ ; E)  $\frac{m-n}{mn}$ .

3.  $\sqrt{2\sqrt{2}\sqrt{1024}}$  ni hisoblang.

A) 64; B) 32; C) 16; D) 4; E)  $2\sqrt{8}$ .

4.  $\sqrt{a^2 - 13a + 45\sqrt{a^2 - 8a + 16}}$  ( $a \leq 4$ ) ifodani soddalashtiring.

A)  $a - 2$ ; B)  $a - 7$ ; C)  $7 - a$ ; D)  $2 - a$ ; E)  $|a - 2|$ .

5.  $\sqrt{1,44 \cdot 0,04 \cdot 0,0001}$  ifoda qiymatini toping.

A) 2,4; B) 0,24; C) 0,024; D) 0,0024; E) 0,00024.

6. Hisoblang:  $\sqrt{10 \cdot 20 \cdot 48 \cdot 36 \cdot 75 \cdot 98}$ .

A) 50400; B) 5040; C) 6040; D) 50800; E) 5080.

7. Hisoblang:  $\frac{81^{0,4} \cdot 3^{0,5}}{9^{0,3} \cdot 27^{\frac{1}{6}}}$ .

A)  $3^{-1}$ ; B)  $3^2$ ; C)  $9^{-1}$ ; D)  $3^{1,2}$ ; E) 3.

8. Hisoblang:  $\sqrt{\frac{36}{49 \cdot 121}}$ .

A) 12,3; B)  $12\frac{5}{6}$ ; C)  $\frac{6}{87}$ ; D)  $\frac{6}{77}$ ; E)  $\frac{2}{7}$ .

9. Hisoblang:  $\sqrt[3]{3\frac{3}{8}} - \sqrt[4]{18} \cdot \sqrt[4]{4\frac{1}{2}} - \sqrt{\sqrt{256}}$ .

A) -5,5; B)  $\sqrt{3} - \sqrt{2}$ ; C)  $\frac{\sqrt{2}}{2}$ ; D) 8,5; E) 6,5.

10. Hisoblang:  $\frac{\sqrt[3]{49} \cdot \sqrt[3]{112}}{\sqrt[3]{250}}$ .

- A) 7,5;    B) 2,8;    C) 1,4;    D)  $\frac{21}{25}$ ;    E) 2,5.

11.  $\sqrt[3]{\sqrt{x^6} y^{12}} - \left(\sqrt[5]{xy^2}\right)^5$  ifodani soddalashtiring.

- A) 1;    B) 0;    C)  $xy$ ;    D)  $2xy^2$ ;    E)  $xy^2 - x^2y$ .

12. Ifodaning qiymatini toping:  $\sqrt{\frac{81^3 - 19^3}{62} + 81 \cdot 19}$ .

- A) 100;    B) 62;    C) 50;    D) 64;    E) 10.

13\*.  $a = \sqrt[4]{10}$ ;  $b = \sqrt{3}$ ,  $c = \sqrt[5]{4}$  sonlarni kamayish tartibida yozing.

- A)  $a, b, c$ ;    B)  $a, c, b$ ;    C)  $b, c, a$ ;    D)  $b, a, c$ ;    E)  $c, a, b$ .

14.  $\frac{16^{3k-3} \cdot 256^{k+1}}{1024^k \cdot 32^{k-1}}$  ifodani soddalashtiring.

- A) 2;    B)  $2^{2k-1}$ ;    C)  $2^{5k+1}$ ;    D)  $2^{-1}$ ;    E)  $2^{2k+1}$ .

15. Hisoblang:  $\sqrt[3]{5\sqrt{2} + 7} \cdot \sqrt[3]{5\sqrt{2} - 7}$ .

- A) 5;    B) 4;    C) 2;    D) -1;    E) 1.

16\*. Soddalashtiring:  $\sqrt{6 + 2\sqrt{5 - \sqrt{13 + \sqrt{48}}}}$ .

- A)  $\sqrt{3} - 1$ ;    B)  $1 - \sqrt{3}$ ;    C)  $\sqrt{3} + 1$ ;    D)  $2\sqrt{3} - 1$ ;    E)  $2\sqrt{3} + 1$ .

17. Sonli ifodaning qiymatini hisoblang:

$81^{0,75} \cdot 32^{-0,4} - 8^{\frac{2}{3}} \cdot 27^{\frac{1}{3}} + 256^{0,5}$ .

- A) 22;    B) 23,5;    C) 16;    D) 9;    E) 18.

18. Hisoblang:  $\frac{5^4 \cdot 49^{-3}}{7^{-7} \cdot 25^3} \cdot 35$ .

- A) 0,28;    B) 1,4;    C) 49;    D) 9,8;    E) 9,2.

19.  $\left(x^{\frac{1}{3}} + y^{\frac{1}{3}}\right)\left(x^{\frac{2}{3}} - x^{\frac{1}{3}}y^{\frac{1}{3}} + y^{\frac{2}{3}}\right) + x^{\frac{1}{3}}y^{\frac{1}{3}}$  ifoda soddalashtirilgandan

keyin nechta haddan iborat bo'ladi?

- A) 6;    B) 3;    C) 5;    D) 4;    E) 2.

20.  $x^{10} = -3$  tenglama nechta ildizga ega?

- A) 10;    B) 8;    C) 5;    D) 3;    E)  $\emptyset$ .

21\*.  $\sqrt{0,5}$ ,  $\sqrt[3]{0,3}$ ,  $\sqrt[5]{0,2}$  sonlarni o'sish tartibida joylashtiring.

- A)  $\sqrt{0,5}$ ,  $\sqrt[3]{0,3}$ ,  $\sqrt[5]{0,2}$ ;    B)  $\sqrt[3]{0,3}$ ,  $\sqrt{0,5}$ ,  $\sqrt[5]{0,2}$ ;  
C)  $\sqrt[5]{0,2}$ ,  $\sqrt[3]{0,3}$ ,  $\sqrt{0,5}$ ;    D)  $\sqrt[5]{0,2}$ ,  $\sqrt{0,5}$ ,  $\sqrt[3]{0,3}$ .

E)  $\sqrt{0.5}, \sqrt[3]{0.2}, \sqrt[3]{0.3}$ .

22.  $\left(\frac{\sqrt{2}}{2} - \frac{1}{2\sqrt{2}}\right)\left(\frac{2-\sqrt{2}}{1+\sqrt{2}} - \frac{2+\sqrt{2}}{\sqrt{2}-1}\right)$  ni soddallashtiring.

A)  $-\frac{3\sqrt{2}}{2}$ ; B)  $\sqrt{2}$ ; C)  $-\sqrt{2}$ ; D)  $-2\sqrt{2}$ ; E)  $-\frac{\sqrt{2}}{2}$ .

23\*.  $a = \sqrt{1990} + \sqrt{1992}$ ,  $b = 2\sqrt{1991}$  sonlarni taqqoslang.

A)  $a = b$ ; B)  $a > b$ ; C)  $a < b$ ; D)  $a - b = 0.5$ ; E)  $b = a + 1$ .

24.  $(\sqrt{3 + \sqrt{5}} + \sqrt{3 - \sqrt{5}})^2$  ni hisoblang.

A) 10; B)  $10\sqrt{2}$ ; C)  $2\sqrt{3 - \sqrt{5}}$ ; D)  $\sqrt{3} - \sqrt{2}$ ; E)  $\sqrt{5} + 10$ .

25\*.  $2\sqrt{3 + \sqrt{5} - \sqrt{13} + \sqrt{48}}$  ifodani soddallashtiring.

A)  $2\sqrt{\sqrt{3} - \sqrt{2}}$ ; B)  $2\sqrt{3} - \sqrt{2}$ ; C)  $\sqrt{3} - \sqrt{2}$ ; D)  $2(\sqrt{5} - \sqrt{3})$ ;  
E)  $\sqrt{6} + \sqrt{2}$ .

26\*.  $\sqrt{28 - 10\sqrt{3}} + \sqrt{28 + 10\sqrt{3}}$  ni hisoblang.

A)  $4 - \sqrt{3}$ ; B)  $2 - \sqrt{3}$ ; C) 10; D) 7; E) 5.

27\*.  $\frac{\sqrt{6} + \sqrt{3} - \sqrt{2} - 1}{\sqrt{6} + 2\sqrt{3} - \sqrt{2} - 2}$  kasrni qisqartiring.

A) -2; B)  $\frac{\sqrt{2}}{2}$ ; C)  $-\frac{\sqrt{2}}{2}$ ; D)  $\sqrt{2}$ ; E)  $\frac{1}{2}$ .

28.  $\frac{b}{\sqrt{a + \sqrt{a^2 - b^2}}}$  kasr maxrajida irratsionallikdan qutiling.

A)  $\frac{1}{a+b}$ ; B)  $\frac{b\sqrt{a - \sqrt{a^2 - b^2}}}{a+b}$ ; C)  $\frac{b\sqrt{a - \sqrt{a^2 + b^2}}}{a-b}$ ;

D)  $\frac{b}{|b|}\sqrt{a - \sqrt{a^2 - b^2}}$ ; E)  $\sqrt{a - \sqrt{a^2 - b^2}}$ .

29\*.  $\frac{1}{\sqrt{2 + \sqrt{3} - \sqrt{5}}}$  kasr maxrajini irratsionallikdan qutqaring.

A)  $\frac{\sqrt{2} + \sqrt{3} + \sqrt{5}}{6}$ ; B)  $\frac{2\sqrt{3} + 3\sqrt{2} + \sqrt{30}}{12}$ ; C)  $\frac{2\sqrt{3} + 3\sqrt{2} - \sqrt{30}}{6}$ ;

D)  $\frac{\sqrt{3} - 2\sqrt{5}}{12}$ ; E)  $\frac{2\sqrt{3} + 3\sqrt{2} - \sqrt{30}}{12}$ .

30.  $\frac{\sqrt[3]{3}}{\sqrt[3]{25}}$  kasr maxrajidagi irratsionallikdan qutiling.

A)  $\frac{\sqrt[3]{15}}{5}$ ; B)  $\frac{\sqrt[3]{25}}{25}$ ; C)  $\frac{\sqrt[3]{15}}{25}$ ; D)  $\frac{\sqrt[3]{75}}{5}$ ; E)  $\frac{\sqrt[3]{225}}{25}$ .



31\*. 1989<sup>1991</sup> qanday raqam bilan tugaydi?

A) 1; B) 3; C) 7; D) 9; E) 4.

32\*. 463<sup>462</sup> qanday raqam bilan tugaydi?

A) 9; B) 1; C) 6; D) 7; E) 3.

33.  $\frac{x^{0.25} - 3^{0.5}}{3 - x^{0.5}}$  kasrni qisqartiring.

A) Kasr qisqarmaydi; B)  $-(x^{\frac{1}{4}} + 3^{\frac{1}{2}})$ ; C)  $-(x^{0.25} + 3^{0.5})^{-1}$ ;  
D)  $(x^{0.25} + 3^{0.5})^{-1}$ ; E)  $x^{0.5} - 3^{0.5}$ .

34.  $\frac{a^{1.5} - b^{1.5}}{b - a}$  kasrni qisqartiring.

A)  $\frac{a^{0.5} - b^{0.5}}{a^{0.5} + b^{0.5}}$ ; B)  $\frac{a^{0.5} + b^{0.5}}{a^{0.5} - b^{0.5}}$ ; C)  $-\frac{a + (ab)^{0.5} + b}{a^{0.5} + b^{0.5}}$ ;  
D)  $\frac{a - (ab)^{0.5} - b}{a^{0.5} + b^{0.5}}$ ; E)  $\frac{a^{0.5} - b^{0.5}}{a + (ab)^{0.5} + b}$ .

35.  $x^{\frac{3}{2}} + 4x^{\frac{1}{2}} + 4$  ni ko'paytuvchilarga ajrating.

A)  $(x^{\frac{1}{2}} + 2)(x^{\frac{3}{2}} + 2)$ ; B)  $(x^{\frac{3}{2}} + 2)(2x^{\frac{1}{2}} + 1)$ ; C)  $(x^{\frac{3}{2}} + 2)^2$ ;  
D)  $(x^{\frac{3}{2}} + 1)(x^{\frac{3}{2}} + 4)$ ; E)  $(x^{\frac{1}{2}} + 2)(x^{\frac{3}{2}} + 1)$ .

36. Ifodani soddalashtiring:  $a^{-\frac{1}{3}}b^{-\frac{1}{3}}(a^{\frac{2}{3}} + b^{\frac{2}{3}}) - (a^{\frac{2}{3}}b^{-\frac{2}{3}})^{\frac{1}{2}}$ .

A)  $a^{-1}b^{-1}$ ; B)  $2a^{\frac{1}{3}}b^{\frac{1}{3}}$ ; C)  $a^{\frac{1}{3}}b^{\frac{1}{3}}$ ; D)  $a^{\frac{1}{3}}b^{-\frac{1}{3}}$ ; E)  $a^{-\frac{1}{3}}b^{\frac{1}{3}}$ .

37\*. Hisoblang:  $\sqrt{3 - 2\sqrt{2}} \cdot \sqrt[4]{17 + 12\sqrt{2}}$ .

A) 5; B)  $\sqrt{2}$ ; C)  $-2\sqrt{2}$ ; D) 1; E) -1.

38\*. Hisoblang:  $\sqrt[3]{2\sqrt{6}} - 5 \cdot \sqrt[6]{49 + 20\sqrt{6}}$ .

A) -1; B) 1; C)  $5\sqrt{6}$ ; D)  $2\sqrt{3}$ ; E)  $\sqrt{6} - 5$ .

39. Ifodani soddalashtiring:

$$\frac{m^{\frac{1}{2}}n^{\frac{1}{6}} - m^{\frac{1}{6}}n^{\frac{1}{6}}}{m^{\frac{1}{3}}n^{\frac{1}{3}} - m^{\frac{1}{6}}n^{\frac{1}{6}}} - \frac{m^{\frac{1}{2}} - n^{\frac{1}{2}}}{m^{\frac{1}{3}}} \cdot \frac{m^{\frac{5}{6}} + m^{\frac{1}{3}}n^{\frac{1}{2}}}{m - n}$$

A)  $m^{\frac{1}{3}} - n^{\frac{1}{3}}$ ; B)  $(mn)^{\frac{1}{6}}$ ; C)  $(mn)^{\frac{1}{3}}$ ; D)  $m^{\frac{1}{2}} - n^{\frac{1}{2}}$ ; E)  $m - n$ .

40.  $\left( \frac{x^{\frac{1}{6}} - x^{\frac{1}{3}}}{1+x} + \frac{1-x^{\frac{1}{6}}}{1-x^{\frac{1}{3}} - x^{\frac{2}{3}}} \right) \cdot \frac{1+x}{1-x}$  ni soddalashtiring:

A)  $\frac{1}{1+\sqrt[3]{x}}$ ; B)  $1+x^{\frac{1}{3}}$ ; C)  $1-x^{\frac{1}{3}}$ ; D)  $1-x^2$ ; E)  $\left(1+x^{\frac{1}{2}}\right)^{-1}$ .

41. Ifodani soddalashtiring:  $\frac{a}{\sqrt[3]{a}-1} + \frac{1}{\sqrt[3]{a}+1} + \frac{1}{1-\sqrt[3]{a}} - \frac{\sqrt[3]{a^2}}{1+\sqrt[3]{a}}$ .

A)  $2 + \sqrt[3]{a^2}$ ; B)  $1 - \sqrt[3]{a^2}$ ; C)  $\frac{1-\sqrt[3]{a}}{1+\sqrt[3]{a}}$ ; D)  $\sqrt[3]{a^2}$ ; E)  $\frac{2}{1-\sqrt[3]{a^2}}$ .

42. Ifodani soddalashtiring:

$$\frac{\left(a^{\frac{1}{3}} + b^{\frac{1}{3}}\right)^3}{a+b+\sqrt[3]{a^2b}+\sqrt[3]{ab^2}} + \frac{\left(\sqrt[3]{a}-\sqrt[3]{b}\right)^3}{a-b-a^{\frac{2}{3}}b^{\frac{1}{3}}+a^{\frac{1}{3}}b^{\frac{2}{3}}}$$

A)  $(a+b)^2$ ; B)  $a+b$ ; C) 1; D) 2; E)  $a^{\frac{1}{3}} - b^{\frac{1}{3}}$ .

43. Ifodani soddalashtiring:  $\frac{a^{\frac{1}{2}} + b^{\frac{1}{2}}}{a^{\frac{1}{2}}} - \frac{a^{\frac{1}{2}}}{a^{\frac{1}{2}} - b^{\frac{1}{2}}} + \frac{b}{a - a^{\frac{1}{2}}b^{\frac{1}{2}}}$ .

A)  $(ab)^{\frac{1}{2}}$ ; B)  $\left(a^{\frac{1}{2}} + b^{\frac{1}{2}}\right)^2$ ; C)  $\left(a^{\frac{1}{2}} - b^{\frac{1}{2}}\right)^2$ ; D) 0; E) 1.

44. Ifodani soddalashtiring:  $\left( \frac{q^{\frac{1}{2}}}{p-p^{\frac{1}{2}}q^{\frac{1}{2}}} + \frac{p^{\frac{1}{2}}}{q-p^{\frac{1}{2}}q^{\frac{1}{2}}} \right) \cdot \frac{pq^{\frac{1}{2}} + p^{\frac{1}{2}}q}{p-q}$ .

A)  $\frac{p}{q}$ ; B)  $\frac{p+q}{p-q}$ ; C)  $\frac{\sqrt{p} + \sqrt{q}}{\sqrt{p} - \sqrt{q}}$ ; D)  $\frac{\sqrt{p} - \sqrt{q}}{\sqrt{p} + \sqrt{q}}$ ; E)  $\frac{\sqrt{q} + \sqrt{p}}{\sqrt{q} - \sqrt{p}}$ .

45. Quyidagi sonlarning qaysi birlari irratsional sonlar?

1.  $\frac{\sqrt{9-4\sqrt{2}}}{\sqrt{8}-1}$       2.  $\frac{\sqrt{2+\sqrt{9+4\sqrt{2}}}}{\sqrt{2}+1}$       3.  $\sqrt{8}$ .

A) faqat 3; B) hammasi; C) faqat 1 va 3; D) faqat 2 va 3; E) faqat 1.

## KVADRAT TENGLAMALAR

## 1-§. Kvadrat tenglama tushunchasi

**1.1. Kvadrat tenglama.** Ta'rif: Ushbu  $ax^2 + bx + c = 0$  ko'rinishdagi tenglama **kvadrat tenglama** deyiladi, bunda  $x$  – o'zgaruvchi,  $a, b, c$  – berilgan sonlar ( $a \neq 0$ ). Agar  $a \neq 1$  bo'lsa, tenglama to'la kvadrat tenglama deyiladi  $a, b, c$  sonlar kvadrat tenglamaning koeffitsiyentlari,  $c$  esa ozod had deyiladi.

Kvadrat tenglamani *ikkinchi darajali tenglama* ham deb ataladi, chunki uning chap qismi ikkinchi darajali ko'phaddan iborat.

O'zgaruvchining kvadrat tenglamani to'g'ri sonli tenglikka aylantiradigan qiymatlari *kvadrat tenglama ildizlari* deyiladi.

**1.2. Chala (to'liqmas) kvadrat tenglama.** Agar

$$ax^2 + bx + c = 0$$

kvadrat tenglamada  $b = 0$  yoki  $c = 0$  bo'lsa, bunday tenglama *chala (to'liqmas) kvadrat tenglama* deyiladi. Chala kvadrat tenglamalar:

$$1) ax^2 + c = 0; \quad 2) ax^2 + bx = 0; \quad 3) ax^2 = 0.$$

Bu turdagi tenglamalarning yechilishini qarab chiqamiz:

$$1) ax^2 + c = 0 \Leftrightarrow ax^2 = -c \Leftrightarrow x^2 = -\frac{c}{a} \Rightarrow$$

$$\Rightarrow \begin{cases} x_{1,2} = \pm \sqrt{-\frac{c}{a}}, & \text{agar } \frac{c}{a} < 0 \text{ bo'lsa,} \\ \text{ildizga ega emas, agar } \frac{c}{a} > 0 \text{ bo'lsa;} \end{cases}$$

$$2) ax^2 + bx = 0 \Leftrightarrow x(ax + b) = 0 \Rightarrow \begin{cases} x_1 = 0, \\ x_2 = -\frac{b}{a}; \end{cases}$$

$$3) ax^2 = 0 \Leftrightarrow x^2 = 0 \Rightarrow [x = 0.$$

Misollar. Ushbu tenglamalarni yeching:

$$1) x^2 - 2 = 0; \quad 2) x^2 = 9; \quad 3) 4x^2 + 6x = 9x^2 - 15x; \quad 4) 2x^2 + 4 = 0.$$

Yechilishi:

$$1) x^2 - 2 = 0 \Leftrightarrow (x + \sqrt{2})(x - \sqrt{2}) = 0 \Rightarrow \begin{cases} x + \sqrt{2} = 0, \\ x - \sqrt{2} = 0 \end{cases} \Rightarrow \begin{cases} x_1 = -\sqrt{2}, \\ x_2 = \sqrt{2}. \end{cases}$$

Javob:  $-\sqrt{2}; \sqrt{2}$ .

$$2) x^2 = 9 \Leftrightarrow x^2 - 9 = 0 \Leftrightarrow (x + 3)(x - 3) = 0 \Rightarrow \begin{cases} x + 3 = 0, \\ x - 3 = 0 \end{cases} \Rightarrow \begin{cases} x_1 = -3, \\ x_2 = 3. \end{cases}$$

Javob:  $-3; 3$ .

$$3) 4x^2 + 6x = 9x^2 - 15x \Leftrightarrow 5x^2 - 21x = 0 \Leftrightarrow x(5x - 21) = 0 \Leftrightarrow$$

$$\Rightarrow \begin{cases} x = 0, \\ 5x - 21 = 0 \end{cases} \Rightarrow \begin{cases} x_1 = 0, \\ x_2 = 4,2. \end{cases}$$

Javob:  $0; 4,2$ .

4)  $2x^2 + 4 = 0 \Leftrightarrow x^2 + 2 = 0 \Rightarrow x^2 = -2$  tenglamaning ildizlari yo'q, chunki kvadrati  $-2$  ga teng son mavjud emas.

Javob: tenglama yechimga ega emas.

**1.3. To'la kvadrat tenglamani yechish.** Ushbu  $ax^2 + bx + c = 0$

( $a \neq 0$ ) tenglamani yechamiz:  $ax^2 + bx + c = 0 \Leftrightarrow x^2 + \frac{b}{a}x + \frac{c}{a} = 0$ .

Bu tenglamada ikkihadning to'la kvadratini ajratamiz:

$$x^2 + \frac{b}{a}x + \frac{c}{a} = 0 \Leftrightarrow x^2 + 2 \cdot \frac{b}{2a}x + \left(\frac{b}{2a}\right)^2 - \left(\frac{b}{2a}\right)^2 + \frac{c}{a} = 0 \Leftrightarrow$$

$$\Leftrightarrow \left(x + \frac{b}{2a}\right)^2 = \frac{b^2}{4a^2} - \frac{c}{a} \Leftrightarrow \left(x + \frac{b}{2a}\right)^2 = \frac{b^2 - 4ac}{4a^2}.$$

Hosil bo'lgan tenglamaning o'ng qismidagi kasrning maxraji musbat bo'lganligi sababli uning ildizlari soni  $b^2 - 4ac$  ifodaning ishorasi bilan bog'liq. Bu ifoda  $ax^2 + bx + c = 0$  tenglamaning *diskriminanti* deyiladi. Uni  $D$  harfi bilan belgilanadi:

$$D = b^2 - 4ac.$$

Diskriminantga bog'liq bo'lgan uchta hol bo'lishi mumkin.

1. Agar  $D > 0$  bo'lsa, u holda

$$\left(x + \frac{b}{2a}\right)^2 = \frac{b^2 - 4ac}{4a^2} \Leftrightarrow x + \frac{b}{2a} = \pm \frac{\sqrt{D}}{2a} \Rightarrow$$

$$\Rightarrow x = -\frac{b}{2a} \pm \frac{\sqrt{D}}{2a} = \frac{-b \pm \sqrt{D}}{2a} = \begin{cases} x_1 = \frac{-b - \sqrt{D}}{2a}, \\ x_2 = \frac{-b + \sqrt{D}}{2a}. \end{cases}$$

Shunday qilib,  $D > 0$  bo'lsa, kvadrat tenglama ikkita haqiqiy  $x_1$  va  $x_2$  ildizlarga ega va ular

$$x_{1,2} = \frac{-b \pm \sqrt{b^2 - 4ac}}{2a}$$

formula bilan topiladi.

2. Agar  $D = 0$  bo'lsa, u holda

$$\left(x + \frac{b}{2a}\right)^2 = 0 \Leftrightarrow x + \frac{b}{2a} = 0 \Rightarrow \left[x = -\frac{b}{2a}\right].$$

Demak, tenglama bitta  $-\frac{b}{2a}$  ildizga ega. Bunday holda tenglama bir-biriga teng  $x_1 = x_2 = -\frac{b}{2a}$  ikki ildizga ega ham deyiladi.

3. Agar  $D < 0$  bo'lsa, u holda

$$\left(x + \frac{b}{2a}\right)^2 = \frac{D}{4a^2}$$

tenglamaning o'ng qismi manfiy bo'ladi va u haqiqiy ildizga ega bo'lmaydi.

1-misol.  $3x^2 + 2x - 2 = 0$  tenglamani yeching.

Yechilishi.  $D = b^2 - 4ac = 4 + 24 = 28 > 0$ ;

$$x_{1,2} = \frac{-2 \pm \sqrt{28}}{2 \cdot 3} = \frac{-2 \pm 2\sqrt{7}}{2 \cdot 3} = -\frac{1}{3} \pm \frac{1}{3}\sqrt{7}.$$

$$\text{Javob: } -\frac{1}{3} - \frac{1}{3}\sqrt{7}; -\frac{1}{3} + \frac{1}{3}\sqrt{7}.$$

2-misol.  $25x^2 - 30x + 9 = 0$  tenglamani yeching.

Yechilishi.  $D = (-30)^2 - 4 \cdot 9 \cdot 25 = 900 - 900 = 0$ ;

$$x_{1,2} = \frac{30 \pm 0}{50} = \frac{30}{50} = \frac{3}{5}.$$

Javob:  $\frac{3}{5}$ .

3-misol.  $2x^2 - 4x + 3 = 0$  tenglamani yeching.

Yechilishi.  $D = (-4)^2 - 4 \cdot 2 \cdot 3 = 16 - 24 = -8 < 0$ .

Javob: tenglama haqiqiy ildizlarga ega emas.

4-misol.  $x^2 - 2ax + a(1+a) = 0$  tenglama  $a$  ning qanday qiymatlarida bitta haqiqiy ildizga ega bo'ladi?

Yechilishi. Berilgan kvadrat tenglama bitta haqiqiy ildizga ega bo'lishi uchun uning diskriminanti 0 ga teng bo'lishi kerak:

$$D = 4a^2 - 4a(1+a) = 0 \Rightarrow 4a^2 - 4a - 4a^2 = 0 \Rightarrow -4a = 0 \Rightarrow [a = 0.$$

Javob: 0.

**1.4. Keltirilgan kvadrat tenglama.** Agar  $x^2$  oldidagi koeffitsiyent 1 ga teng bo'lsa, bu tenglama *keltirilgan kvadrat tenglama* deyiladi.

Keltirilgan kvadrat tenglama umumiy holda

$$x^2 + px + q = 0$$

ko'rinishda yoziladi, bunda  $p$  va  $q$  - berilgan sonlar.

Keltirilgan kvadrat tenglamani  $ax^2 + bx + c = 0$  to'la kvadrat tenglamada  $a = 1$ ,  $b = p$ ,  $c = q$  bo'lgan xususiy hol deb qarash mumkin.

Keltirilgan kvadrat tenglama ildizlari

$$x_{1,2} = \frac{-p \pm \sqrt{p^2 - 4q}}{2}$$

formula bilan topiladi. Bu yerda diskriminant

$$D = p^2 - 4q.$$

Agar  $D > 0$  bo'lsa, keltirilgan kvadrat tenglama ikkita haqiqiy ildizga ega.

Agar  $D = 0$  bo'lsa, keltirilgan kvadrat tenglama bitta haqiqiy ildizga ega.

Agar  $D < 0$  bo'lsa, tenglamaning haqiqiy ildizlari yo'q.

Har qanday  $ax^2 + bx + c = 0$  tenglamani uni  $a$  ga bo'lish yo'li bilan keltirilgan kvadrat tenglamaga keltirish mumkin:

$$ax^2 + bx + c = 0 \Leftrightarrow x^2 + \frac{b}{a}x + \frac{c}{a} = 0.$$

Agar keltirilgan kvadrat tenglamaning  $p$  koeffitsiyenti juft son bo'lsa, uning ildizlarini

$$x_{1,2} = -\frac{p}{2} \pm \sqrt{\left(\frac{p}{2}\right)^2 - q}$$

formula bilan topish qulay.

Misol.  $x^2 - 8x + 7 = 0$  tenglamani yeching.

$$\text{Yechilishi: } x_{1,2} = 4 \pm \sqrt{16 - 7} = 4 \pm \sqrt{9} = 4 \pm 3 \Rightarrow \begin{cases} x_1 = 1, \\ x_2 = 7. \end{cases}$$

Javob: 1; 7.

## 2-§. Viyet teoremasi

**Teorema.** Agar keltirilgan kvadrat tenglama haqiqiy ildizlarga ega bo'lsa, bu ildizlarning yig'indisi qarama-qarshi ishora bilan olingan  $x$  oldidagi koeffitsiyentga, ularning ko'paytmasi esa shu tenglamaning ozod hadiga teng, ya'ni  $x^2 + px + q = 0$  tenglamada

$D = p^2 - 4q > 0$  bo'lsa,

$$x_1 + x_2 = -p, \quad x_1 x_2 = q.$$

Masalan,  $x^2 - 7x - 8 = 0$  tenglama uchun  $D = 49 + 32 = 81 > 0$ ;

$$x_{1,2} = \frac{7 \pm 9}{2} \Rightarrow \begin{cases} x_1 = -1, \\ x_2 = 8; \end{cases} \quad x_1 + x_2 = -1 + 8 = 7, \quad x_1 x_2 = (-1) \cdot 8 = -8.$$

$$x_{1,2} = \frac{-b \pm \sqrt{b^2 - 4ac}}{2a}$$

formula bilan topiladi.

2. Agar  $D = 0$  bo'lsa, u holda

$$\left(x + \frac{b}{2a}\right)^2 = 0 \Leftrightarrow x + \frac{b}{2a} = 0 \Rightarrow \left[x = -\frac{b}{2a}\right]$$

Demak, tenglama bitta  $-\frac{b}{2a}$  ildizga ega. Bunday holda tenglama bir-biriga teng  $x_1 = x_2 = -\frac{b}{2a}$  ikki ildizga ega ham deyiladi.

3. Agar  $D < 0$  bo'lsa, u holda

$$\left(x + \frac{b}{2a}\right)^2 = \frac{D}{4a^2}$$

tenglamaning o'ng qismi manfiy bo'ladi va u haqiqiy ildizga ega bo'lmaydi.

1-misol.  $3x^2 + 2x - 2 = 0$  tenglamani yeching.

Yechilishi.  $D = b^2 - 4ac = 4 + 24 = 28 > 0$ ;

$$x_{1,2} = \frac{-2 \pm \sqrt{28}}{2 \cdot 3} = \frac{-2 \pm 2\sqrt{7}}{2 \cdot 3} = -\frac{1}{3} \pm \frac{1}{3}\sqrt{7}.$$

$$\text{Javob: } -\frac{1}{3} - \frac{1}{3}\sqrt{7}; -\frac{1}{3} + \frac{1}{3}\sqrt{7}.$$

2-misol.  $25x^2 - 30x + 9 = 0$  tenglamani yeching.

Yechilishi.  $D = (-30)^2 - 4 \cdot 9 \cdot 25 = 900 - 900 = 0$ ;

$$x_{1,2} = \frac{30 \pm 0}{50} = \frac{30}{50} = \frac{3}{5}.$$

Javob:  $\frac{3}{5}$ .

3-misol.  $2x^2 - 4x + 3 = 0$  tenglamani yeching.

Yechilishi.  $D = (-4)^2 - 4 \cdot 2 \cdot 3 = 16 - 24 = -8 < 0$ .

Javob: tenglama haqiqiy ildizlarga ega emas.

4-misol.  $x^2 - 2ax + a(1+a) = 0$  tenglama  $a$  ning qanday qiymatlarida bitta haqiqiy ildizga ega bo'ladi?

Yechilishi. Berilgan kvadrat tenglama bitta haqiqiy ildizga ega bo'lishi uchun uning diskriminanti 0 ga teng bo'lishi kerak:

$$D = 4a^2 - 4a(1+a) = 0 \Rightarrow 4a^2 - 4a - 4a^2 = 0 \Rightarrow -4a = 0 \Rightarrow [a = 0.$$

Javob: 0.

**1.4. Keltirilgan kvadrat tenglama.** Agar  $x^2$  oldidagi koeffitsiyent 1 ga teng bo'lsa, bu tenglama *keltirilgan kvadrat tenglama* deyiladi.

Keltirilgan kvadrat tenglama umumiy holda

$$x^2 + px + q = 0$$

ko'rinishda yoziladi, bunda  $p$  va  $q$  - berilgan sonlar.

Keltirilgan kvadrat tenglamani  $ax^2 + bx + c = 0$  to'la kvadrat tenglamada  $a = 1$ ,  $b = p$ ,  $c = q$  bo'lgan xususiy hol deb qarash mumkin.

Keltirilgan kvadrat tenglama ildizlari

$$x_{1,2} = \frac{-p \pm \sqrt{p^2 - 4q}}{2}$$

formula bilan topiladi. Bu yerda diskriminant

$$D = p^2 - 4q.$$

Agar  $D > 0$  bo'lsa, keltirilgan kvadrat tenglama ikkita haqiqiy ildizga ega.

Agar  $D = 0$  bo'lsa, keltirilgan kvadrat tenglama bitta haqiqiy ildizga ega.

Agar  $D < 0$  bo'lsa, tenglamaning haqiqiy ildizlari yo'q.

Har qanday  $ax^2 + bx + c = 0$  tenglamani uni  $a$  ga bo'lish yo'li bilan keltirilgan kvadrat tenglamaga keltirish mumkin:

$$ax^2 + bx + c = 0 \Leftrightarrow x^2 + \frac{b}{a}x + \frac{c}{a} = 0.$$

Agar keltirilgan kvadrat tenglamaning  $p$  koeffitsiyenti juft son bo'lsa, uning ildizlarini

$$x_{1,2} = -\frac{p}{2} \pm \sqrt{\left(\frac{p}{2}\right)^2 - q}$$

formula bilan topish qulay.

Misol.  $x^2 - 8x + 7 = 0$  tenglamani yeching.

$$\text{Yechilishi: } x_{1,2} = 4 \pm \sqrt{16 - 7} = 4 \pm \sqrt{9} = 4 \pm 3 \Rightarrow \begin{cases} x_1 = 1, \\ x_2 = 7. \end{cases}$$

Javob: 1; 7.

## 2-§. Viyet teoremasi

**Teorema.** Agar keltirilgan kvadrat tenglama haqiqiy ildizlarga ega bo'lsa, bu ildizlarning yig'indisi qarama-qarshi ishora bilan olingan  $x$  oldidagi koeffitsiyentga, ularning ko'paytmasi esa shu tenglamaning ozod hadiga teng, ya'ni  $x^2 + px + q = 0$  tenglamada  $D = p^2 - 4q > 0$  bo'lsa,

$$x_1 + x_2 = -p, \quad x_1 x_2 = q.$$

Masalan,  $x^2 - 7x - 8 = 0$  tenglama uchun  $D = 49 + 32 = 81 > 0$ :

$$x_{1,2} = \frac{7 \pm 9}{2} \Rightarrow \begin{cases} x_1 = -1, \\ x_2 = 8; \end{cases} \quad x_1 + x_2 = -1 + 8 = 7, \quad x_1 x_2 = (-1) \cdot 8 = -8.$$



Umumiy  $ax^2 + bx + c = 0$  kvadrat tenglama uchun Viyet teoremasi quyidagicha yoziladi:

$$x_1 + x_2 = -\frac{b}{a}, \quad x_1 \cdot x_2 = \frac{c}{a}.$$

Viyet teoremasiga teskari teorema. Agar  $x_1 + x_2 = -p$  va  $x_1 x_2 = q$  tengliklarni qanoatlantiruvchi  $x_1$  va  $x_2$  haqiqiy sonlar mavjud bo'lsa, bu sonlar  $x^2 + px + q = 0$  keltirilgan kvadrat tenglamaning ildizlari bo'ladi.

Masalalar yechishda Viyet teoremasi va unga teskari teorema tatbiqiga doir bir necha misollar ko'ramiz.

1-masala. Ildizlari  $-15$  va  $22$  ga teng bo'lgan kvadrat tenglamani tuzing.

Yechilishi.  $x^2 + px + q = 0$  kvadrat tenglama koeffitsiyentlarini Viyet teoremasidan topamiz:

$$p = -(-15 + 22) = -7, \quad q = (-15) \cdot 22 = -330.$$

Shunday qilib, izlanayotgan tenglama:  $x^2 - 7x - 330 = 0$ .

Javob:  $x^2 - 7x - 330 = 0$ .

Eslatma. Ildizlari  $-15$  va  $22$  ga teng bo'lgan cheksiz ko'p kvadrat tenglama tuzish mumkin. Buning uchun tuzilgan  $x^2 - 7x - 330 = 0$  tenglamaning har bir hadini noldan va birdan farqli ixtiyoriy songa ko'paytirish kifoya. Masalan:

$$2x^2 - 14x - 660 = 0, \quad 3x^2 - 21x - 990 = 0 \text{ va hokazo.}$$

2-masala.  $x_1$  va  $x_2$  sonlar  $x^2 + 2x - 14 = 0$  tenglamaning ildizlari bo'lsa,  $\frac{x_1}{x_2} + \frac{x_2}{x_1}$  ning qiymatini toping.

Yechilishi. Viyet teoremasiga ko'ra  $x_1 + x_2 = -2$ ,  $x_1 x_2 = -14$  tengliklar o'rinligidan foydalanamiz:

$$\frac{x_1}{x_2} + \frac{x_2}{x_1} = \frac{x_1^2 + x_2^2}{x_1 \cdot x_2} = \frac{(x_1 + x_2)^2 - 2x_1 x_2}{x_1 \cdot x_2}.$$

Bu ifodaga  $x_1 + x_2$  yig'indi va  $x_1 x_2$  ko'paytma qiymatlarini qo'yamiz:

$$\frac{(-2)^2 - 2 \cdot (-14)}{-14} = -\frac{4 + 28}{14} = -\frac{32}{14} = -\frac{16}{7} = -2\frac{2}{7}.$$

Javob:  $-2\frac{2}{7}$ .

3-masala.  $x^2 - 13x + q = 0$  tenglamaning ildizlaridan biri  $12,5$  ga teng. Tenglamaning koeffitsiyentlari yig'indisini toping.

Yechilishi: 1-usul. Masala shartiga ko'ra tenglamaning ildizlaridan biri  $12,5$  ga teng:  $x_1 = 12,5$ . U holda Viyet teoremasiga ko'ra

$$\begin{cases} 12,5 + x_2 = 13, \\ 12,5 \cdot x_2 = q \end{cases} \Rightarrow \begin{cases} x_2 = 0,5, \\ q = 6,25. \end{cases}$$

Tenglamaning koeffitsiyentlari yig'indisini topamiz:

$$1 - 13 + 6,25 = -5,75.$$

2-usul. Tenglama ildizlaridan biri 12,5 ga teng bo'lganligi sababli bu son berilgan tenglamani qanoatlantiradi:

$$(12,5)^2 - 13 \cdot 12,5 + q = 0 \Leftrightarrow 156,25 - 162,5 + q = 0 \Leftrightarrow [q = 6,25.$$

Tenglamaning koeffitsiyentlari yig'indisi:

$$1 - 13 + 6,25 = -5,75.$$

Javob:  $-5,75$ .

4-masala.  $x^2 + px + q = 0$  tenglama ildizlari  $x_1$  va  $x_2$  ekanligi ma'lum. Ildizlari berilgan tenglama ildizlaridan  $k$  marta ortiq bo'lgan kvadrat tenglama tuzing.

Yechilishi. Izlanayotgan tenglama  $t^2 + mt + n = 0$  shaklda bo'lsin. Masala shartiga ko'ra

$$t_1 = kx_1, \quad t_2 = kx_2.$$

Berilgan tenglamadan Viyet teoremasiga ko'ra

$$x_1 + x_2 = -p, \quad x_1 x_2 = q.$$

Izlanayotgan kvadrat tenglama uchun ham Viyet teoremasi o'rinli. Shuning uchun

$$m = -(t_1 + t_2) = -(kx_1 + kx_2) = -k(x_1 + x_2) = kp;$$

$$n = t_1 \cdot t_2 = kx_1 \cdot kx_2 = k^2(x_1 \cdot x_2) = k^2q.$$

Shunday qilib, izlanayotgan tenglama ushbu

$$t^2 + kpt + k^2q = 0$$

shaklda yoziladi. Bu tenglamadagi o'zgaruvchini  $x$  bilan almashtirsak,

$$x^2 + kpx + k^2q = 0.$$

Javob:  $x^2 + kpx + k^2q = 0$ .

Kvadrat tenglamaga keltiriladigan masalalarning yechilishiga doir misollar keltiramiz.

5-masala. Ketma-ket kelgan ikkita natural son kvadratlari-ning yig'indisi bu sonlar ko'paytmasidan 57 ga ortiq. Shu sonlarni toping.

Yechilishi. Bu ikki sondan kichigini  $x$  desak, ikkinchi son  $x + 1$  ga teng bo'ladi. Masala shartiga ko'ra

$$x^2 + (x + 1)^2 = x(x + 1) + 57.$$

Hosil qilingan shu tenglamani yechamiz:

$$x^2 + (x + 1)^2 = x(x + 1) + 57 \Leftrightarrow x^2 + x^2 + 2x + 1 = x^2 + x + 57 \Leftrightarrow$$

$$\Leftrightarrow x^2 + x - 56 = 0 \Rightarrow x_{1,2} = \frac{-1 \pm \sqrt{1+224}}{2} = \frac{-1 \pm 15}{2} \Rightarrow \begin{cases} x_1 = -8, \\ x_2 = 7. \end{cases}$$

Izlanayotgan sonlar natural sonlar bo'lganligi uchun  $-8$  soni masalaning yechimi bo'la olmaydi. Ketma-ket natural sonlardan birinchisi 7 ga, ikkinchisi esa 8 ga teng.

Javob: 7 va 8.

6-masala. Bolalar oyoq kiyimining narxi 2500 so'm edi. Ikki marta ketma-ket bir xil protsentga arzonlashtirilgandan keyin uning narxi 2025 so'm bo'ldi. Oyoq kiyimining narxi ikki safar ham necha protsentga arzonlashtirilgan?

Yechilishi. Bolalar oyoq kiyimining narxi ikki marta ham  $x\%$  ga arzonlashtirilgan bo'lsin. Demak, oyoq kiyimining birinchi marta arzonlashtirilgandan keyin o'zining dastlabki narxidan  $\frac{x}{100}$  qismga kamayadi, ya'ni uning narxi

$$2500 \left(1 - \frac{x}{100}\right) \text{ so'm}$$

bo'ladi. Shunga o'xshash, ikkinchi marta ham  $x\%$  ga arzonlashtirilgandan keyin oldingi arzonlashtirish natijasidagi narx ham  $\frac{x}{100}$  qismga kamayadi, ya'ni bolalar oyoq kiyimining narxi

$$2500 \cdot \left(1 - \frac{x}{100}\right) \cdot \left(1 - \frac{x}{100}\right) \text{ so'm}$$

bo'ladi. Shunday qilib,

$$2500 \cdot \left(1 - \frac{x}{100}\right)^2 = 2025.$$

Bu tenglamani yechamiz:

$$\begin{aligned} 2500 \cdot \left(1 - \frac{x}{100}\right)^2 = 2025 &\Leftrightarrow \left(1 - \frac{x}{100}\right)^2 = \frac{81}{100} \Leftrightarrow 1 - \frac{x}{50} + \frac{x^2}{10000} - \frac{81}{100} = 0 \Leftrightarrow \\ \Leftrightarrow x^2 - 200x + 1900 = 0 &\Rightarrow x_{1,2} = 100 \pm \sqrt{10000 - 1900} = 100 \pm 90 = \\ = \begin{cases} x_1 = 10, \\ x_2 = 190. \end{cases} \end{aligned}$$

Oyoq kiyimi 190% ga arzonlashtirilishi mumkin emas, demak, u 10% ga arzonlashtirilgan.

Javob: 10%.

### 3-§. Kvadrat tenglamaga keltiriladigan yuqori darajali tenglamalar

Ba'zi yuqori darajali algebraik tenglamalarni kvadrat tenglamaga keltirib yechish mumkin. Shunday tenglamalardan ayrim muhim hollarini ko'rib chiqamiz.

Ushbu

$$ax^4 + bx^3 + cx^2 + dx + e = 0 \quad (1)$$

ko'rinishdagi tenglama *to'rtinchi darajali tenglama* deyiladi. Bunda  $a \neq 0$  bo'lib,  $a, b, c, d, e$  tenglama koeffitsiyentlari haqiqiy sonlardir. (1) tenglamaning haqiqiy ildizlarini xususiy hollarda topish usullari bilan tanishib chiqamiz.

**3.1. Bikvadrat tenglamalar.** Agar (1) tenglamada  $b = d = 0$  bo'lsa, u holda tenglama

$$ax^4 + cx^2 + e = 0$$

ko'rinishni oladi. Bunday shakldagi tenglama *bikvadrat tenglama* deyiladi. Tenglama koeffitsiyentlarini qabul qilingan tartibda yozsak,

$$ax^4 + bx^2 + c = 0 \quad (2)$$

tenglamaga ega bo'lamiz. Agar  $D = b^2 - 4ac \geq 0$  bo'lsa, tenglamani yechishda

$$x^2 = t \quad (t \geq 0) \quad (3)$$

almashtirishdan foydalaniladi. Natijada

$$at^2 + bt + c = 0$$

kvadrat tenglamaga ega bo'lamiz. Ma'lumki,  $t_{1,2} = \frac{-b \pm \sqrt{b^2 - 4ac}}{2a}$ .

Agar  $t_1 \geq 0$ ,  $t_2 \geq 0$  bo'lsa, (2) tenglama ildizlari (3) ga ko'ra quyidagicha topiladi:

$$\begin{cases} x^2 = t_1 \\ x^2 = t_2 \end{cases} \Leftrightarrow \begin{cases} (x - \sqrt{t_1})(x + \sqrt{t_1}) = 0 \\ (x - \sqrt{t_2})(x + \sqrt{t_2}) = 0 \end{cases} \Leftrightarrow \begin{cases} x_{1,2} = \pm \sqrt{t_1} \\ x_{3,4} = \pm \sqrt{t_2} \end{cases}$$

1-misol.  $x^4 - 4x^2 - 5 = 0$  tenglamani yeching.

Yechilishi.  $x^2 = t, t^2 - 4t - 5 = 0$

$$\Rightarrow t_{1,2} = 2 \pm \sqrt{4+5} = 2 \pm 3 \Rightarrow \begin{cases} t_1 = -1, \\ t_2 = 5. \end{cases}$$

$x^2 = -1$  tenglama haqiqiy ildizlarga ega emas.

$$x^2 = 5 \Rightarrow (x - \sqrt{5})(x + \sqrt{5}) = 0 \Rightarrow x_{1,2} = \pm\sqrt{5}$$

Javob:  $\{\pm\sqrt{5}\}$ .

**3.2. Qaytma tenglamalar.** Agar to'rtinchi darajali (1) tenglama koeffitsiyentlari uchun  $a = e$  va  $b = d$  tengliklar o'rinli bo'lsa, u holda bunday tenglama «qaytma» tenglama deyiladi.

Quyida bu tenglamani yechish uslubini ko'rib chiqamiz.

2-misol.  $2x^4 + 3x^3 - 16x^2 + 3x + 2 = 0$  tenglamani yeching.

Yechilishi.  $x \neq 0$  bo'lganligi uchun, tenglamaning har ikkala tomonini  $x^2$  ga bo'lamiz:

$$2x^2 + 3x - 16 + \frac{3}{x} + \frac{2}{x^2} = 0 \Leftrightarrow 2\left(x^2 + \frac{1}{x^2}\right) + 3\left(x + \frac{1}{x}\right) - 16 = 0.$$

endi  $x + \frac{1}{x} = t$  almashtirishni bajaramiz.

U holda  $x^2 + \frac{1}{x^2} = t^2 - 2$ . Natijada  $t$  ga nisbatan ushbu tenglamaga ega bo'lamiz:

$$2(t^2 - 2) + 3t - 16 \neq 0 \Leftrightarrow 2t^2 + 3t - 20 = 0.$$

Bu tenglamalarning ildizlarini topamiz:

$$t_{1,2} = \frac{-3 \pm \sqrt{9 + 160}}{4} \Rightarrow \begin{cases} t_1 = -4, \\ t_2 = \frac{5}{2}. \end{cases}$$

Kiritilgan almashtirishni inobatga olib, berilgan tenglama ildizlarini topamiz:

$$x + \frac{1}{x} = -4 \Leftrightarrow x^2 + 4x + 1 = 0 \Rightarrow x_{1,2} = \frac{-4 \pm \sqrt{16 - 4}}{2} = -2 \pm \sqrt{3} \Rightarrow \begin{cases} x_1 = -2 - \sqrt{3}, \\ x_2 = -2 + \sqrt{3}. \end{cases}$$

$$x + \frac{1}{x} = \frac{5}{2} \Leftrightarrow 2x^2 - 5x + 2 = 0 \Rightarrow x_{3,4} = \frac{5 \pm \sqrt{25 - 16}}{4} = \frac{5 \pm 3}{4} \Rightarrow \begin{cases} x_3 = \frac{1}{2}, \\ x_4 = 2. \end{cases}$$

Berilgan tenglama to'rtta haqiqiy ildizga ega:

$$x_1 = -2 - \sqrt{3}, \quad x_2 = -2 + \sqrt{3}, \quad x_3 = \frac{1}{2}, \quad x_4 = 2.$$

Agar (1) tenglama koeffitsiyentlari uchun  $\frac{a}{e} = \frac{b^2}{d^2}$  tenglik o'rinli bo'lsa ham, u «qaytma» tenglama kabi yechiladi.

3-misol.  $2x^4 - 21x^3 + 74x^2 - 105x + 50 = 0$  tenglamani yeching.

Yechilishi.  $\frac{a}{e} = \frac{2}{50} = \frac{1}{25}$ ;  $\frac{b^2}{d^2} = \frac{21 \cdot 21}{105 \cdot 105} = \frac{1}{25}$ .

Demak, ko'rsatilgan shartlar bajarilyapti:  $x^2 \neq 0$ .

Tenglamani har ikkala tomonini  $x^2$  ga bo'lamiz:

$$2x^2 - 21x + 74 - \frac{105}{x} + \frac{50}{x^2} = 0 \Leftrightarrow 2\left(x^2 + \frac{25}{x^2}\right) - 21\left(x + \frac{5}{x}\right) + 74 = 0.$$

Endi  $x + \frac{5}{x} = t$  almashtirishni bajarib,  $t$  ga nisbatan ushbu tenglamaga ega bo'lamiz:

$$2t^2 - 21t + 54 = 0.$$

Bu tenglamani ildizlarini topamiz:

$$t_{1,2} = \frac{21 \pm \sqrt{441 - 432}}{4} = \frac{21 \pm 3}{4} \Rightarrow \begin{cases} t_1 = 6, \\ t_2 = \frac{9}{2}. \end{cases}$$

Kiritilgan almashtirishni inobatga olib, berilgan tenglama ildizlarini topamiz:

$$x + \frac{5}{x} = 6 \Leftrightarrow x^2 - 6x + 5 = 0 \Rightarrow \begin{cases} x_1 = 1, \\ x_2 = 5. \end{cases}$$

$$x + \frac{5}{x} = \frac{9}{2} \Leftrightarrow 2x^2 - 9x + 10 = 0 \Rightarrow \begin{cases} x_3 = \frac{5}{2}, \\ x_4 = 2. \end{cases}$$

Berilgan tenglama to'rtta haqiqiy ildizga ega:

$$x_1 = 1, x_2 = 5, x_3 = \frac{5}{2}, x_4 = 2.$$

**3.3. O'zaro teskari ifodalar ishtirok etgan tenglamalar.** Bunday tenglamalarni yechilishini ushbu misol yordamida ko'rib chiqamiz:

4-misol.  $\left(\frac{x}{x+1}\right)^2 - \left(\frac{x+1}{x}\right)^2 = \frac{3}{2}$  tenglamani yeching.

Yechilishi. Berilgan tenglama  $x$  ning  $x = -1$  va  $x = 0$  qiymatlaridan boshqa barcha qiymatlarida aniqlangan, ya'ni  $x \neq -1$

va  $x \neq 0$ .  $\left(\frac{x}{x+1}\right)^2 = t$  ( $t \geq 0$ ) almashtirishni bajaramiz. U holda  $\left(\frac{x+1}{x}\right)^2 = \frac{1}{t}$  bo'ladi. Natijada  $t$  ga nisbatan ushbu tenglama hosil bo'ladi:

$$t - \frac{1}{t} = \frac{3}{2} \Leftrightarrow 2t^2 - 3t - 2 = 0$$

Bu tenglamaning ildizlarini topamiz:

$$t_{1,2} = \frac{3 \pm \sqrt{9+16}}{4} = \frac{3 \pm 5}{4} \Rightarrow \begin{cases} t_1 = -\frac{1}{2}, \\ t_2 = 2. \end{cases}$$

Qabul qilingan almashtirishlarga ko'ra  $\left(\frac{x}{x+1}\right)^2 = -\frac{1}{2}$ ; bu tenglama haqiqiy ildizlarga ega emas:

$$\left(\frac{x}{x+1}\right)^2 = 2 \Leftrightarrow \frac{x^2}{x^2+2x+1} = 2 \Leftrightarrow x^2 = 2x^2 + 4x + 2 \Leftrightarrow x^2 + 4x + 2 = 0;$$

$$x_{1,2} = -2 \pm \sqrt{4-2} \Rightarrow \begin{cases} x_1 = -2 - \sqrt{2}, \\ x_2 = -2 + \sqrt{2}. \end{cases}$$

Shunday qilib, berilgan tenglama ikkita  $x_1 = -2 - \sqrt{2}$ ,  $x_2 = -2 + \sqrt{2}$  haqiqiy ildizga ega.

**3.4. To'la kvadratni ajratish usuli bilan kvadrat tenglamaga keltiriladigan to'rtinchi darajali tenglamalar.** To'rtinchi darajali tenglamalarni yechishda to'la kvadratni ajratish usuli bilan uning tartibini pasaytirib, kvadrat tenglamaga keltirishdan ham foydalanish ko'pgina hollarda qo'l keladi.

5-misol.  $x^4 + 6x^3 + 5x^2 - 12x + 3 = 0$  tenglamaning haqiqiy ildizlarini toping.

Yechilishi. Tenglamaning chap tomonida to'la kvadratni ajratamiz:

$$x^4 + 6x^3 + 5x^2 - 12x + 3 = 0 \Leftrightarrow \frac{x^4 + 6x^3 + 9x^2}{(x^2+3x)^2} - 4x^2 - 12x + 3 = 0 \Leftrightarrow$$

$$\Leftrightarrow (x^2 + 3x)^2 - 4(x^2 + 3x) + 3 = 0$$

Endi  $x^2 + 3x = t$  almashtirish yordamida  $t$  ga nisbatan ushbu kvadrat tenglamani hosil qilamiz:

$$t^2 - 4t + 3 = 0.$$

Bu tenglamaning ildizlarini topamiz:

$$t_{1,2} = 2 \pm \sqrt{4-3} \Rightarrow \begin{cases} t_1 = 1. \\ t_2 = 3. \end{cases}$$

Qabul qilingan almashtirishni hisobga olib, berilgan tenglamaning haqiqiy ildizlarini topamiz:

$$1) x^2 + 3x = 1 \Leftrightarrow x^2 + 3x - 1 = 0 \Leftrightarrow x_{1,2} = \frac{-3 \pm \sqrt{9+4}}{2} = \frac{-3 \pm \sqrt{13}}{2} \Rightarrow$$

$$\Rightarrow \begin{cases} x_1 = -\frac{3}{2} - \frac{\sqrt{13}}{2}, \\ x_2 = -\frac{3}{2} + \frac{\sqrt{13}}{2}; \end{cases}$$

$$2) x^2 + 3x = 3 \Leftrightarrow x^2 + 3x - 3 = 0 \Leftrightarrow x_{3,4} = \frac{-3 \pm \sqrt{9+12}}{2} = \frac{-3 \pm \sqrt{21}}{2} \Rightarrow$$

$$\Rightarrow \begin{cases} x_3 = -\frac{3}{2} - \frac{\sqrt{21}}{2}, \\ x_4 = -\frac{3}{2} + \frac{\sqrt{21}}{2}. \end{cases}$$

$$\text{Javob: } -\frac{3}{2} - \frac{\sqrt{13}}{2}, -\frac{3}{2} + \frac{\sqrt{13}}{2}, -\frac{3}{2} - \frac{\sqrt{21}}{2}, -\frac{3}{2} + \frac{\sqrt{21}}{2}.$$

#### 4-§. Yuqori darajali tenglamalar sistemalari

Birinchi darajali ikki noma'lumli tenglamalar sistemasi IV bobda ko'rilgan edi. Bu paragrafda ikkinchi va uchinchi darajali tenglamalar sistemalarini yechishga misollar keltiramiz.

Avval tenglamalaridan biri birinchi darajali, ikkinchisi esa ikkinchi darajali ikki noma'lumli tenglamalar sistemasini ko'ramiz.

$$\text{I-misol. } \begin{cases} x + 2y = 1, \\ x^2 - 3xy - 2y^2 = 2 \end{cases} \text{ tenglamalar sistemasini yeching.}$$



Bunday tenglamalar odatda o'rniga qo'yish usuli bilan yechiladi. Birinchi darajali tenglamada noma'lum  $x$  ni  $y$  orqali (yoki  $y$  ni  $x$  orqali) ifodalab, ikkinchi darajali tenglamaga qo'yish natijasida  $x$  yoki  $y$  ga nisbatan kvadrat tenglama hosil qilinadi. Agar bu kvadrat tenglama haqiqiy ildizlarga esa bo'lsa, berilgan sistema ham yechimga ega bo'ladi, aksincha bo'lsa, yechimga ega bo'lmaydi.

Tenglamalar sistemasini yechamiz:

$$\begin{cases} x + 2y = 1, \\ x^2 - 3xy - 2y^2 = 2 \end{cases} \Leftrightarrow \begin{cases} x = 1 - 2y, \\ (1 - 2y)^2 - 3(1 - 2y)y - 2y^2 = 2 \end{cases} \Leftrightarrow$$

$$\Leftrightarrow \begin{cases} x = 1 - 2y, \\ 8y^2 - 7y - 1 = 0 \end{cases} \Rightarrow \begin{cases} x_1 = 1\frac{1}{4}, \\ x_2 = -1; \\ y_1 = -\frac{1}{8}, \\ y_2 = 1. \end{cases}$$

Javob:  $(1\frac{1}{4}; -\frac{1}{8}), (-1; 1)$ .

Tenglamalaridan ikkitasi birinchi darajali, bittasi ikkinchi darajali uch noma'lumli tenglamalar sistemasini ham yuqoridagi usul bilan yechish mumkin.

2 - misol.  $\begin{cases} x + y - z + 1 = 0, \\ x - y - z + 3 = 0, \\ x^2 + 2xy + y^2 - xz + z^2 + x - 5 = 0 \end{cases}$  tenglamalar sis-

temasini yeching.

Yechilishi:  $\begin{cases} x + y - z + 1 = 0, \\ x - y - z + 3 = 0, \\ x^2 + 2xy + y^2 - xz + z^2 + x - 5 = 0 \end{cases} \Leftrightarrow$

$$\Leftrightarrow \begin{cases} y = z - x - 1, \\ x - (z - x - 1) - z + 3 = 0, \\ x^2 + 2x(z - x - 1) + (z - x - 1)^2 - xz + z^2 + x - 5 = 0 \end{cases} \Leftrightarrow$$

$$\Leftrightarrow \begin{cases} y = z - x - 1, \\ 2x - 2z + 4 = 0, \\ 2z^2 - xz + x - 2z - 4 = 0 \end{cases} \Leftrightarrow \begin{cases} y = z - x - 1, \\ x = z - 2, \\ 2z^2 - z(z - 2) + z - 2 - 2z - 4 = 0 \end{cases} \Leftrightarrow$$

$$\Leftrightarrow \begin{cases} y = z - x - 1, \\ x = z - 2, \\ z^2 + z - 6 = 0 \end{cases} \Leftrightarrow \begin{cases} y_1 = 1, y_2 = 1, \\ x_1 = -5, x_2 = 0, \\ z_1 = -3, z_2 = 2. \end{cases}$$

Javob:  $(-5; 1; -3), (0; 1; 2)$ .

Ikki noma'lumli tenglamalar sistemasining har ikki tenglamasi ham ikkinchi darajali tenglamalardan iborat bo'lsa, bunday tenglamalar sistemasini yechish murakkabroq. Tenglamaning berilishiga qarab o'rniga qo'yish usulidan, qo'shish usulidan, yangi o'zgaruvchilar kiritish kabi usullardan foydalanish mumkin. Bir necha misollar qaraymiz.

3-misol. Tenglamalar sistemasini yeching:

$$\begin{cases} x^2 + y^2 + x + y = 32, \\ xy + 2(x + y) = 26. \end{cases}$$

Yechilishi:  $x + y = u$ ,  $xy = v$  belgilashlar orqali yangi  $u$  va  $v$  o'zgaruvchilar kiritamiz. U holda  $x^2 + y^2 = (x + y)^2 - 2xy = u^2 - 2v$  ekanligini hisobga olib, ushbu

$$\begin{cases} u^2 - 2v + u = 32, \\ v + 2u = 26 \end{cases}$$

tenglamalar sistemasiga ega bo'lamiz. Bu sistemani o'rniga qo'yish usuli bilan yechish mumkin:

$$\begin{aligned} \begin{cases} u^2 - 2v + u = 32, \\ v + 2u = 26 \end{cases} &\Leftrightarrow \begin{cases} u^2 - 2(26 - 2u) + u = 32, \\ v = 26 - 2u \end{cases} \Leftrightarrow \\ &\Leftrightarrow \begin{cases} u^2 + 5u - 84 = 0, \\ v = 26 - 2u \end{cases} \Rightarrow \begin{cases} u_1 = -12, u_2 = 7, \\ v_1 = 50, v_2 = 12. \end{cases} \end{aligned}$$

Eski o'zgaruvchilarga qaytib, quyidagi ikkita sistemani hosil qilamiz:

$$\begin{cases} x + y = -12, \\ xy = 50 \end{cases} \Leftrightarrow \begin{cases} x + y = 7, \\ xy = 12. \end{cases}$$

Bu tenglamalar sistemasini har birini o'rniga qo'yish usuli bilan yechamiz:

$$1) \begin{cases} x + y = -12, \\ xy = 50 \end{cases} \Leftrightarrow \begin{cases} x = -(y + 12), \\ -(y + 12)y = 50 \end{cases} \Leftrightarrow \begin{cases} x = -(y + 12), \\ y^2 + 12y + 50 = 0. \end{cases}$$

Bu sistema yechimga ega emas, chunki hosil bo'lgan kvadrat tenglamada  $D < 0$ .

$$2) \begin{cases} x + y = 7, \\ xy = 12 \end{cases} \Leftrightarrow \begin{cases} y = 7 - x, \\ x(7 - x) = 12 \end{cases} \Leftrightarrow \begin{cases} y = 7 - x, \\ x^2 - 7x + 12 = 0 \end{cases} \Rightarrow \begin{cases} y_1 = 4; y_2 = 3; \\ x_1 = 3; x_2 = 4. \end{cases}$$

Javob: (3; 4), (4; 3).

4-misol. Ushbu  $\begin{cases} \frac{x}{y} + \frac{y}{x} = \frac{13}{6}, \\ x + y = 5 \end{cases}$  tenglamalar sistemasini yeching.

Yechilishi:  $\frac{x}{y} = t$  belgilash bilan yangi  $t$  o'zgaruvchi kiritamiz.

U holda  $\frac{y}{x} = \frac{1}{t}$  bo'ladi va sistemaning birinchi tenglamasi

$$t + \frac{1}{t} = \frac{13}{6}$$

ko'rinishga keladi. Bu tenglamani yechamiz:

$$6t^2 - 13t + 6 = 0 \Rightarrow t_{1,2} = \frac{13 \pm \sqrt{169 - 144}}{12} \Rightarrow \begin{cases} t_1 = \frac{2}{3}, \\ t_2 = \frac{3}{2}. \end{cases}$$

Shunday qilib,

$$\begin{cases} \frac{x}{y} = \frac{2}{3} \Rightarrow y = \frac{3x}{2}, \\ \frac{x}{y} = \frac{3}{2} \Rightarrow y = \frac{2x}{3}. \end{cases}$$

ekanligidan, berilgan sistema ushbu

$$\begin{cases} y = \frac{3x}{2}, \\ x + y = 5 \end{cases} \text{ va } \begin{cases} y = \frac{2x}{3}, \\ x + y = 5 \end{cases}$$

tenglamalar sistemalariga teng kuchli bo'ladi. Bu sistemalarni yechib,  $x_1 = 2; y_1 = 3$  va  $x_2 = 3; y_2 = 2$  larni topamiz.

Javob: (2; 3), (3; 2).

5-misol. 
$$\begin{cases} x^3 + x^3y^3 + y^3 = 17, \\ x + xy + y = 5 \end{cases}$$
 tenglamalar sistemasini yeching.

Yechilishi. *Simmetrik tenglamalar* (har bir tenglamasida  $x$  ni  $y$  bilan,  $y$  ni  $x$  bilan almashtirish natijasida o'zgarmaydigan tenglamalar) deb ataluvchi bunday tenglamalar sistemasini yechishda ham  $x + y = u$  va  $xy = v$  belgilashlar orqali yangi o'zgaruvchilar kiritiladi.

Sistemaning birinchi tenglamasidagi kublar yig'indisini yangi o'zgaruvchilar bilan ifodalaymiz:

$$x^3 + y^3 = (x + y)((x + y)^2 - 3xy) = u(u^2 - 3v).$$

Berilgan tenglamalar sistemasi  $u$  va  $v$  o'zgaruvchilarga nisbatan ushbu

$$\begin{cases} u^3 - 3uv + v^3 = 17, \\ u + v = 5 \end{cases}$$

shaklda yoziladi. Hosil bo'lgan sistemani yechamiz:

$$\begin{cases} u^3 - 3uv + v^3 = 17, \\ u + v = 5 \end{cases} \Leftrightarrow \begin{cases} (u + v)(u^2 - uv + v^2) - 3uv = 17, \\ u + v = 5 \end{cases} \Leftrightarrow$$

$$\Leftrightarrow \begin{cases} 5(u^2 - uv + v^2) - 3uv = 17, \\ u + v = 5 \end{cases} \Leftrightarrow \begin{cases} 5(u^2 + v^2) - 8uv = 17, \\ u + v = 5 \end{cases} \Leftrightarrow$$

$$\Leftrightarrow \begin{cases} 5((u + v)^2 - 2uv) - 8uv = 17, \\ u + v = 5 \end{cases} \Leftrightarrow \begin{cases} 5(25 - 2uv) - 8uv = 17, \\ u + v = 5 \end{cases} \Leftrightarrow$$

$$\Leftrightarrow \begin{cases} uv = 6, \\ u + v = 5 \end{cases} \Rightarrow \begin{cases} u_1 = 2; v_1 = 3, \\ u_2 = 3; v_2 = 2. \end{cases}$$

Shunday qilib, berilgan sistema

$$\begin{cases} x + y = 2, \\ xy = 3 \end{cases} \text{ va } \begin{cases} x + y = 3, \\ xy = 2 \end{cases}$$

sistemalar to'plamiga teng kuchli bo'ladi. Ularni yechib  $x_1 = 1; y_1 = 2$  va  $x_2 = 2; y_2 = 1$  larni topamiz.

Javob: (1; 2), (2; 1).

6-misol. 
$$\begin{cases} x^2 + 3xy + 2y^2 = 3, \\ 5x^2 - 2xy - y^2 = 5 \end{cases}$$
 tenglamalar sistemasini yeching.

Yechilishi. Sistemaning birinchi tenglamasini  $-5$  ga, ikkinchi tenglamasini  $3$  ga ko'paytirib, ularni hadma-had qo'shish natijasida  $x$  va  $y$  ga nisbatan bir jinsli ikkinchi darajali

$$10x^2 - 21xy - 13y^2 = 0$$

tenglamani hosil qilamiz. Bundan

$$x = \frac{21y \pm \sqrt{441y^2 + 520y^2}}{20} = \frac{21y \pm 31y}{20} \Rightarrow \begin{cases} x = -\frac{1}{2}y, \\ x = \frac{13}{5}y. \end{cases}$$

Shunday qilib, berilgan tenglamalar sistemasi

$$\begin{cases} x^2 + 3xy + 2y = 3, \\ y = -2x \end{cases} \text{ va } \begin{cases} x^2 + 3xy + 2y = 3, \\ y = \frac{5}{13}x \end{cases}$$

sistemalar to'plamiga teng kuchli bo'ladi. Ularni yechib,

$$x_1 = 1; y_1 = -2; x_2 = -1; y_2 = 2, x_3 = \frac{13}{\sqrt{138}}; y_3 = \frac{5}{\sqrt{138}};$$

$$x_4 = -\frac{13}{\sqrt{138}}; y_4 = -\frac{5}{\sqrt{138}} \text{ larni topamiz.}$$

Javob: (1; -2), (-1; 2),  $\left(\frac{13}{\sqrt{138}}; \frac{5}{\sqrt{138}}\right)$   $\left(-\frac{13}{\sqrt{138}}; -\frac{5}{\sqrt{138}}\right)$ .

7-misol. 
$$\begin{cases} x(y+z) = 20, \\ y(x+z) = 18, \\ z(x+y) = 14 \end{cases}$$
 tenglamalar sistemasini yeching.

Yechilishi. Uchala tenglamani hadma-had qo'shamiz:

$$2xy + 2xz + 2yz = 52 \Leftrightarrow xy + xz + yz = 26.$$

Hosil bo'lgan tenglikka ketma-ket

$$xy + xz = 20,$$

$$xy + yz = 18,$$

$$xz + yz = 14$$

qiymatlarni qo'shib, berilgan sistemaga teng kuchli ushbu

$$\begin{cases} yz = 6, \\ xz = 8, \\ xy = 12 \end{cases}$$

tenglamalar sistemasini hosil qilamiz. Bu tenglamalarni hadma-had ko'paytiramiz:

$$(xyz)^2 = 576 \Leftrightarrow \begin{cases} xyz = -24, \\ xyz = 24. \end{cases}$$

Bularga ketma-ket  $yz = 6$ ;  $xz = 8$ ;  $xy = 12$  qiymatlarni qo'yib, berilgan tenglamalar sistemasining yechimlarini hosil qilamiz:  $x_1 = -4$ ;  $y_1 = -3$ ;  $z_1 = -2$ ;  $x_2 = 4$ ;  $y_2 = 3$ ;  $z_2 = 2$ .

Javob:  $(-4; -3; -2)$ ,  $(4; 3; 2)$ .

## 5-§. Kvadrat uchhad

**5.1. Kvadrat uchhad tushunchasi.**  $ax^2 + bx + c$  ko'rinishidagi ifoda o'zgaruvchi  $x$  ga nisbatan kvadrat uchhad deb ataladi, bunda  $a$ ,  $b$  va  $c$  — berilgan sonlar ( $a \neq 0$ ).

$$D = b^2 - 4ac$$

ifoda, ya'ni  $ax^2 + bx + c = 0$  tenglamaning diskriminanti  $ax^2 + bx + c$  kvadrat uchhadning ham diskriminanti deyiladi, shunga o'xshash, kvadrat tenglamaning ildizlari ham kvadrat uchhadning ildizlari yoki nollari deyiladi.

**5.2. Kvadrat uchhadni chiziqli ko'paytuvchilarga ajratish.** Agar kvadrat uchhadning diskriminanti musbat bo'lsa ( $b^2 - 4ac > 0$ ), u

$$ax^2 + bx + c = a(x - x_1)(x - x_2) \quad (1)$$

shaklda chiziqli ko'paytuvchilarga ajraladi.

(1) ayniyatni isbotlash uchun uning o'ng qismida Viyet teoremasidan foydalanib, almashtirishlar bajaramiz:

$$\begin{aligned} a(x - x_1)(x - x_2) &= a(x^2 - xx_1 - xx_2 + x_1x_2) = \\ &= a(x^2 - (x_1 + x_2)x + x_1x_2) = \left( ax^2 + \frac{b}{a}x + \frac{c}{a} \right) = ax^2 + bx + c. \end{aligned}$$

Agar kvadrat uchhadning diskriminanti nolga teng bo'lsa ( $b^2 - 4ac = 0$ ) ham (1) ayniyat to'g'ri bo'ladi. Haqiqatan ham bu holda  $x_1 = x_2$  va

$$ax^2 + bx + c = a(x - x_1)(x - x_1) = a(x - x_1)^2.$$

1-misol.  $2x^2 - 5x - 3$  kvadrat uchhadni ko'paytuvchilarga ajrating.

Yechilishi. Kvadrat uchhad diskriminantining ishorasini aniqlaymiz:

$$D = 25 + 24 = 49 > 0.$$

Kvadrat uchhad ildizlarini topamiz:

$$x_{1,2} = \frac{5 \pm \sqrt{49}}{4} = \frac{5 \pm 7}{4} \Rightarrow \begin{cases} x_1 = -\frac{1}{2}, \\ x_2 = 3. \end{cases}$$

Berilgan kvadrat uchhad uchun (1) ayniyatni yozamiz:

$$2x^2 - 5x - 3 = 2\left(x + \frac{1}{2}\right)(x - 3) = (2x + 1)(x - 3).$$

Javob:  $(2x + 1)(x - 3)$ .

2-misol.  $-25x^2 + 10x - 1$  kvadrat uchhadni ko'paytuvchilarga ajrating.

Yechilishi.  $D = 100 - 4 \cdot 25 = 100 - 100 = 0$ ;  $x_1 = x_2 = \frac{10}{50} = \frac{1}{5}$ ;

$$25x^2 + 10x - 1 = -25\left(x - \frac{1}{5}\right)\left(x - \frac{1}{5}\right) = -25\left(x - \frac{1}{5}\right)^2 = -(5x - 1)^2.$$

Javob:  $-(5x - 1)^2$ .

Eslatma: 1) agar kvadrat uchhad diskriminanti nolga teng bo'lsa, uni har doim to'la kvadrat shaklida tasvirlash mumkin;

2) agar kvadrat uchhadning diskriminanti manfiy bo'lsa, uni chizikli ko'paytuvchilarga ajratib bo'lmaydi.

3-misol.  $k$  ning qanday qiymatlarida

$$x^2 + 2(k - 9)x + k^2 + 3k + 4$$

ifodani to'la kvadrat shaklida tasvirlab bo'ladi?

Yechilishi.

$$D = (2(k - 9))^2 - 4(k^2 + 3k + 4) = 0 \Leftrightarrow 4(k^2 - 18k + 81) -$$

$$-4k^2 - 12k - 16 = 0 \Leftrightarrow 4k^2 - 72k + 324 - 4k^2 - 12k - 16 = 0;$$

$$84k = 308 \Rightarrow \left[ k = \frac{11}{3} \right].$$

Javob:  $\frac{11}{3}$ .

4-misol.  $\frac{x-5}{3x^2-13x-10}$  kasrni qisqartiring.

Yechilishi. Kasr maxrajini ko'paytuvchilarga ajratamiz:

$$x_{1,2} = \frac{13 \pm \sqrt{169+120}}{6} = \frac{13 \pm 17}{6} \Rightarrow \begin{cases} x_1 = -\frac{2}{3}, \\ x_2 = 5; \end{cases}$$

$$3x^2 - 13x - 10 = 3\left(x + \frac{2}{3}\right)(x - 5) = (3x + 2)(x - 5).$$

Shunday qilib,

$$\frac{x-5}{3x^2-13x-10} = \frac{x-5}{(3x+2)(x-5)} = \frac{1}{3x+2}.$$

Javob:  $\frac{1}{3x+2}$ .

### 6-§. Ratsional tenglamalar

Ushbu

$$2x + 5 = 3(8 - x), 2(x^2 + 1)(x - 1) = 6x - (x + 7),$$

$$2 - \frac{x+1}{x-1} = 0; \frac{x-1}{x+2} - \frac{x-4}{x-3} = -1; \frac{1}{x+1} - \frac{1}{x+2} = \frac{1}{x+3} - \frac{1}{x+4}$$

tenglamalarning chap va o'ng qismlari ratsional ifodalardir. Bunday tenglamalar *ratsional tenglamalar* deyiladi. Ham chap, ham o'ng qismlari butun ifodalar bo'lgan ratsional tenglama *butun ratsional tenglama* deyiladi. Chap yoki o'ng qismi kasr ifodalar bo'lgan ratsional tenglamalar *kasr ratsional tenglama* deyiladi.

Ikkinchi darajali butun ratsional tenglamalar  $ax^2 + bx + c = 0$  ko'rinishiga, uchinchi darajali tenglamalar  $ax^3 + bx^2 + cx + d = 0$ , to'rtinchi darajalilari esa VI.3 da ko'rilgan  $ax^4 + bx^3 + cx^2 + dx + e = 0$  va hokazo ko'rinishlarga keltirilishi mumkin. Yuqori darajali tenglamalarning ayrimlari maxsus usullar bilangina yechilishi mumkin. Ratsional tenglamalarni yechilishini misollarda ko'rib chiqamiz.

1-misol.  $x^3 - 8x^2 - x + 8 = 0$  tenglamani yeching.

Yechilishi. Tenglamani chap qismini guruhlash usuli bilan ko'paytuvchilarga ajratamiz:

$$x^3 - 8x^2 - x + 8 = 0 \Leftrightarrow x^2(x - 8) - (x - 8) = 0 \Leftrightarrow (x - 8)(x^2 - 1) = 0 \Leftrightarrow$$

$$\Leftrightarrow (x - 8)(x - 1)(x + 1) = 0 \Leftrightarrow \begin{cases} x - 8 = 0, \\ x + 1 = 0, \\ x - 1 = 0, \end{cases} \Rightarrow \begin{cases} x_1 = 8, \\ x_2 = -1, \\ x_3 = 1. \end{cases}$$

Javob: -1; 1; 8.



2-misol.  $(x^2 - 5x + 4)(x^2 - 5x + 6) = 120$  tenglamani yeching.

Yechilishi. Tenglamaning chap qismini ushbu

$$(x^2 - 5x + 4)(x^2 - 5x + 4 + 2) = 120$$

shaklda yozish mumkin. Bunda chap tomondagi har ikki ko'paytuvchida bir xil  $x^2 - 5x + 4$  ifoda borligi uchun

$$x^2 - 5x + 4 = y$$

belgilash kiritib, yangi o'zgaruvchi kiritish mumkin. U holda  $y$  o'zgaruvchili ushbu

$$y(y + 2) = 120$$

tenglamaga ega bo'lamiz. Shu tenglamani yechamiz:

$$y(y + 2) = 120 \Leftrightarrow y^2 + 2y - 120 = 0 \Rightarrow$$

$$\Rightarrow y_{1,2} = -1 \pm \sqrt{1 + 121} = -1 \pm 11 \Rightarrow \begin{cases} y_1 = -12, \\ y_2 = 10. \end{cases}$$

Shunday qilib, dastlabki tenglama quyidagi

$$x^2 - 5x + 4 = -12,$$

$$x^2 - 5x + 4 = 10$$

tenglamalarni yechishga keltirildi. Ularni yechamiz:

1)  $x^2 - 5x + 4 = -12 \Leftrightarrow x^2 - 5x + 16 = 0$ . Bu tenglamalarning haqiqiy ildizlari yo'q, chunki uning diskriminanti  $D = 25 - 64 = -39 < 0$ .

$$2) x^2 - 5x + 4 = 10 \Leftrightarrow x^2 - 5x - 6 = 0 \Rightarrow \begin{cases} x_1 = 6, \\ x_2 = -1. \end{cases}$$

Javob:  $-1; 6$ .

3-misol.  $x^3 + x - 4 = 0$  tenglama nechta haqiqiy ildizga ega?

Yechilishi. Berilgan tenglamani grafik usul bilan yechamiz. Buning uchun uni  $x^3 = -x + 4$  shaklda yozib, bitta chizmada  $y = x^3$  va  $y = -x + 4$  funksiyalar grafiklarini yasaymiz. Bu grafiklar kesishish nuqtasining absissasi  $x_0 = 1,4$  berilgan tenglama ildizi bo'ladi (36-rasm). Demak, tenglama bitta haqiqiy ildizga ega.

Javob: 1 ta.

4-misol.  $\frac{x-3}{x-5} + \frac{1}{x} = \frac{x+5}{x(x-5)}$  tenglamani yeching.

Yechilishi. Tenglamadagi kasr ratsional ifodalar o'zgaruvchi  $x$  ning  $x = 0$  va  $x = 5$  qiymatlaridan tashqari barcha qiymatlarida ma'noga ega. Buni e'tiborga olib tenglamani yechamiz:

$$\frac{x-3}{x-5} + \frac{1}{x} = \frac{x+5}{x(x-5)} \Leftrightarrow \frac{x-3}{x-5} + \frac{1}{x} - \frac{x+5}{x(x-5)} = 0 \Leftrightarrow x(x-3) + x - 5 -$$

$$-x-5 = 0 \Leftrightarrow x^2 - 3x - 10 = 0 \Rightarrow \begin{cases} x_1 = 5, \\ x_2 = -2 \end{cases} \Rightarrow [x = -2.$$

O'zgaruvchining  $x = 5$  qiymatida tenglama ma'noga ega bo'lmaganligi sababli u tenglama ildizi bo'la olmaydi.

J a v o b :  $-2$ .

5-misol.  $\frac{x^2+4x-21}{x^2-x-3} = 0$  tenglamani yeching.

$$\text{Yechilishi: } \begin{cases} x^2 + 4x - 21 = 0, \\ x^2 - x - 3 \neq 0 \end{cases} \Leftrightarrow \begin{cases} (x-3)(x+7) = 0, \\ x \neq 0, 5(1 \pm \sqrt{13}) \end{cases} \Rightarrow \begin{cases} x_1 = 3, \\ x_2 = -7. \end{cases}$$

O'zgaruvchi  $x$  ning  $x = 3$  va  $x = -7$  qiymatlarida tenglama maxraj nolga teng emas.

J a v o b :  $-7; 3$ .

6-misol.  $\frac{2}{x^2-4} - \frac{1}{x^2-2x} = \frac{4-x}{x^2+2x}$  tenglamaning ildizlari yig'indisini toping.

Yechilishi. Berilgan tenglamani undagi kasr ratsional ifodalar maxrajlari nolga teng bo'lmasligi sharti bilan yechamiz.

$$\frac{2}{x^2-4} - \frac{1}{x^2-2x} = \frac{4-x}{x^2+2x} \Leftrightarrow \begin{cases} (x-2)\frac{2}{(x+2)} - \frac{1}{x(x-2)} - \frac{4-x}{x(x+2)} = 0, \\ x \neq -2, x \neq 0, x \neq 2 \end{cases} \Leftrightarrow$$

$$\Leftrightarrow \begin{cases} 2x - x - 2 - (x-2)(4-x) = 0, \\ x \neq -2, x \neq 0, x \neq 2 \end{cases} \Rightarrow$$

$$\Rightarrow \begin{cases} (x-2) + (x-2)(x-4) = 0, \\ x \neq -2, x \neq 0, x \neq 2 \end{cases} \Rightarrow$$

$$\Rightarrow \begin{cases} (x-2)(1+x-4) = 0, \\ x \neq -2, x \neq 0, x \neq 2 \end{cases} \Rightarrow [x = 3.$$

Tenglamaning yagona ildizi  $x = 3$  bo'lganligi uchun ildizlar yig'indisi ham 3 ga teng.

J a v o b :  $3$ .

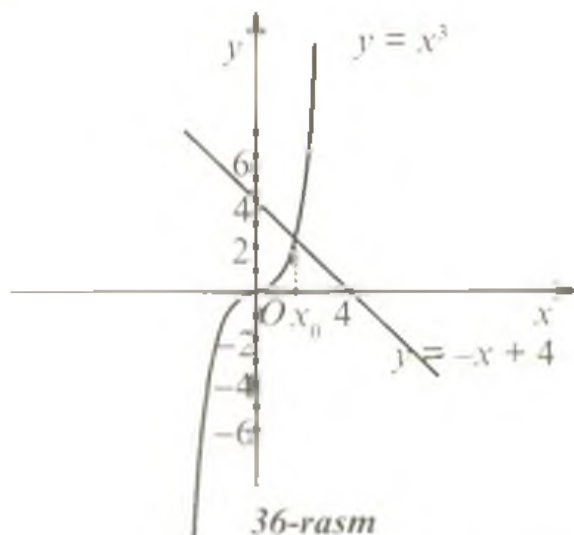

36-rasm

## 7-§. Kvadrat funksiya va uning grafigi

**7.1. Kvadrat funksiya tushunchasi.** Ta'rif.  $y = ax^2 + bx + c$  formula yordamida berish mumkin bo'lgan funksiya kvadrat funksiya deyiladi, bunda  $x$  – erkli o'zgaruvchi,  $a$ ,  $b$  va  $c$  – berilgan sonlar,  $a \neq 0$ .

Bu funksiya haqiqiy sonlar o'qida aniqlangan bo'lib, grafigi paraboladan iborat. Parabolani koordinatalar tekisligidagi holati  $ax^2 + bx + c$  kvadrat uchhadning koeffitsiyentlariga bog'liq. Bu bog'liqlikni bosqichma-bosqich ko'rib chiqamiz.

**7.2.  $y = ax^2$  funksiya grafigi.** Agar  $a = 1$ ,  $b = c = 0$  bo'lsa, kvadrat funksiya  $y = x^2$  ko'rinishda bo'lib, bu funksiya grafigi 35-rasmda keltirilgan.

Agar  $b = c = 0$  bo'lsa,  $y = ax^2$  funksiyaga ega bo'lamiz. Bu funksiya grafigini yasash uchun  $y = x^2$  parabolani  $|a|$  koeffitsiyent bilan  $Ox$  o'qidan cho'zish (yoki qisish) kerak. Funksiya grafigi ushbu xususiyatlarga ega:

1. Grafik koordinatalar boshidan o'tadi.
2. Grafik simmetriya o'qiga ega, u ordinatalar o'qidir.
3.  $a > 0$  bo'lganda grafik koordinatalar tekisligining  $Ox$  o'qidan yuqori qismida joylashgan bo'lib, parabola tarmoqlari yuqoriga yo'nalgan bo'ladi.
4.  $a < 0$  bo'lganda grafik koordinatalar tekisligining pastki qismida joylashadi va parabola tarmoqlari pastga yo'nalgan bo'ladi.

37-rasmda  $a$  ning  $1$ ;  $-1$ ;  $3$ ;  $-\frac{1}{2}$  qiymatlari uchun  $y = ax^2$  funksiyaning grafiklari tasvirlangan.

**7.3.  $y = a(x + x_0)^2$  funksiyaning grafigi.** Bu funksiya grafigi ham parabola bo'lib,  $x_0 > 0$  bo'lganda  $y = ax^2$  funksiya grafigini  $Ox$  o'qi bo'ylab  $|x_0|$  masofa qadar chapga surishdan hosil bo'ladi.  $y = ax^2$  parabolaning uchi  $(0; 0)$  koordinatali nuqta, simmetriya o'qi esa  $x = 0$  ( $Oy$  o'qi) to'g'ri chiziq  $|x_0|$  masofaga ko'chirilganda  $(-x_0; 0)$  koordinatali nuqtaga va

$$x = -x_0$$

to'g'ri chiziqqa o'tadi (38-rasm).

$x_0 < 0$  bo'lganda  $y = a(x + x_0)^2$  funksiya grafigi  $y = ax^2$  funksiya grafigini  $Ox$  o'qi bo'ylab  $|x_0|$  masofa qadar o'ngga surishdan hosil bo'ladi. Natijada  $y = ax^2$  parabolaning uchi  $(x_0; 0)$  koordinatali nuqtaga, simmetriya o'qi esa

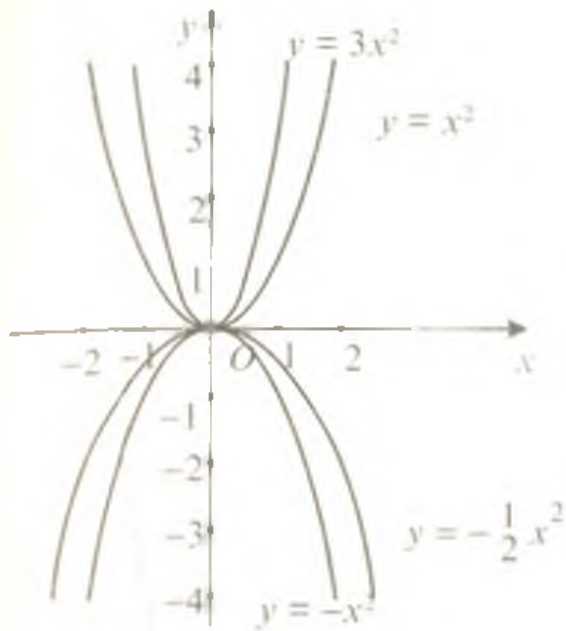

37-rasm

$a > 0$

$x_0 > 0$

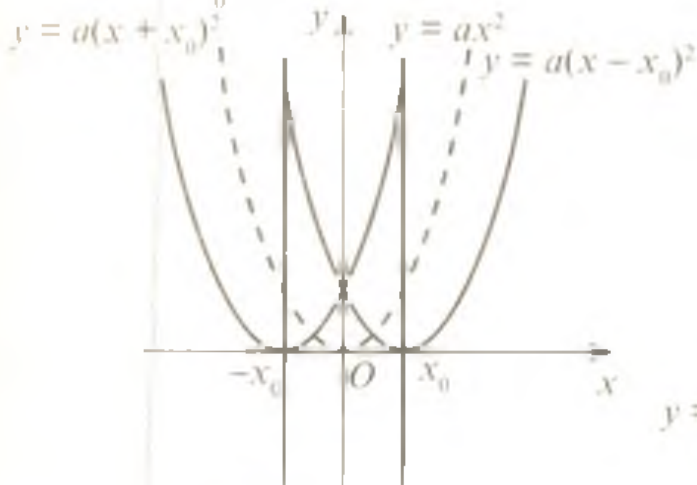

38-rasm

$a < 0$

$x_0 > 0$

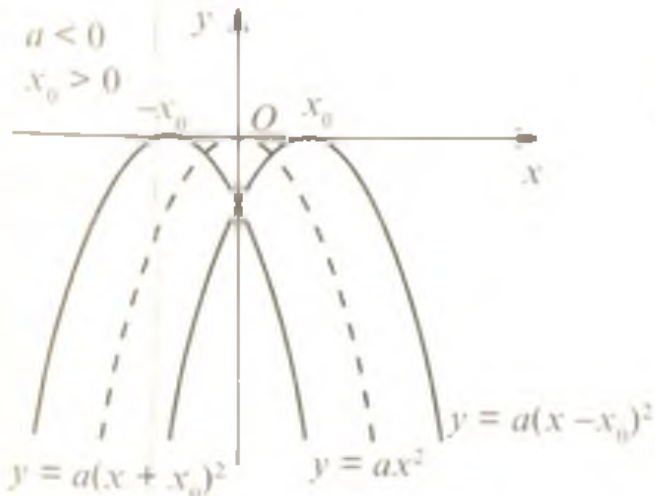

39-rasm

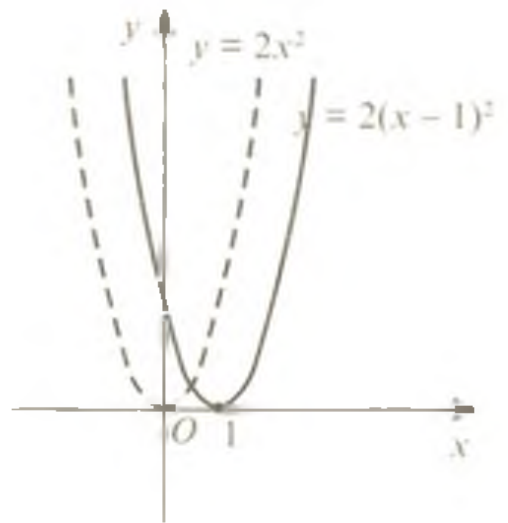

40-rasm

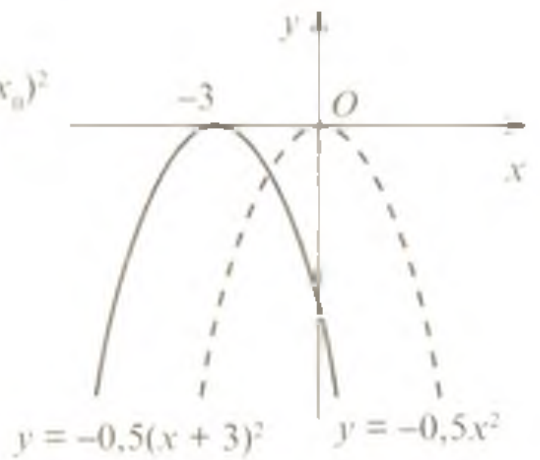

41-rasm

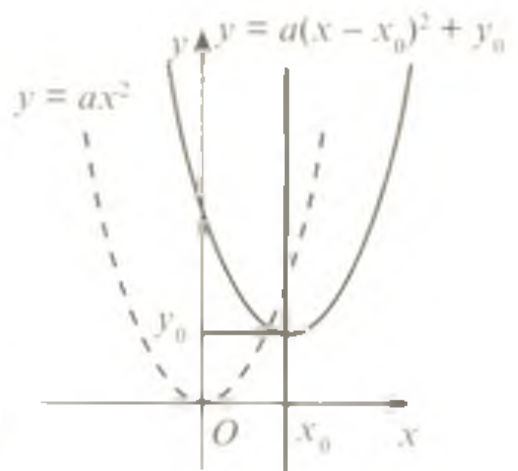

42-rasm

$$x = x_0$$

to'g'ri chiziqqa o'tadi.

$y = a(x + x_0)^2$  funksiya grafigi ham

$$y = ax^2$$

funksiya grafigi kabi  $a > 0$  da yuqoriga,  $a < 0$  da esa pastga yo'nalgan bo'ladi (38, 39-rasmlar). 40-rasmda

$$y = 2x^2 \text{ va } y = 2(x - 1)^2$$

funksiyalarning grafiklari, 41-rasmda esa

$$y = -0,5x^2 \text{ va } y = -0,5(x + 3)^2$$

funksiyalarning grafiklari tasvirlangan.

**7.4.  $y = a(x + x_0)^2 + y_0$  funksiyaning grafigi.** Bu funksiya grafigi agar  $y_0 > 0$  bo'lsa,  $y = a(x + x_0)^2$  funksiya grafigini  $Oy$  o'qi bo'ylab  $|y_0|$  masofaga qadar yuqoriga, agar  $y_0 < 0$  bo'lsa, pastga ko'chirishdan hosil bo'ladi (42, 43-rasmlar). Ko'chirish natijasida uchi  $(x_0; y_0)$  koordinatali nuqtada bo'lgan parabola hosil bo'ladi. Bu parabolaning simmetriya o'qi  $x = x_0$  to'g'ri chiziq bo'ladi.  $y = a(x + x_0)^2$  parabola yuqoriga yoki pastga siljirilganda uning tarmoqlari yo'nalishini o'zgartirmaydi. Shuning uchun  $y = a(x + x_0)^2 + y_0$  va  $y = a(x + x_0)^2$  parabolalar bir xil yo'nalishga ega bo'ladi.

44-rasmda  $y = -0,5(x + 3)^2 + 1$  funksiyaning grafigi tasvirlangan, bu grafik

$$y = -0,5(x + 3)^2$$

funksiyaning grafigini 1 birlik yuqoriga ko'chirishdan hosil bo'lgan. 45-rasmda esa  $y = 2(x - 1)^2 - 3$  funksiyaning grafigi tasvirlangan, bu grafik  $y = 2(x - 1)^2$  funksiyaning grafigini simmetriya o'qi bo'ylab 3 birlik pastga ko'chirishdan hosil bo'lgan.

**7.5.  $y = ax^2 + bx + c$  funksiyaning grafigi.** Bu funksiyaning

$$y = a \left( x + \frac{b}{2a} \right)^2 - \frac{b^2 - 4ac}{4a}$$

ko'rinishida yozish mumkin. Bu ifoda  $a(x - x_0)^2 + y_0$  ko'rinishga ega, bunda

$$x_0 = -\frac{b}{2a}; \quad y_0 = -\frac{b^2 - 4ac}{4a}$$

Shuning uchun uchi  $\left( -\frac{b}{2a}; -\frac{b^2 - 4ac}{4a} \right)$  koordinatali nuqtada bo'lgan parabola  $y = ax^2 + bx + c$  funksiyaning grafigi bo'ladi. Funksiya grafigini yasashga doir misollar keltiramiz.

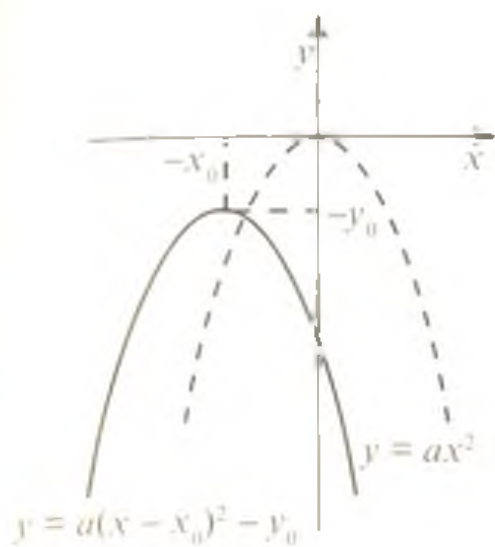

43-rasm

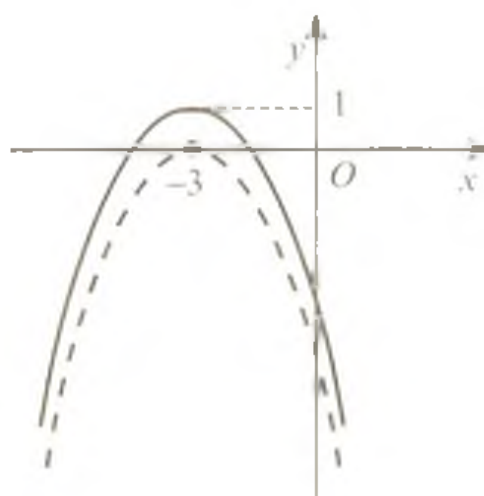

44-rasm



45-rasm

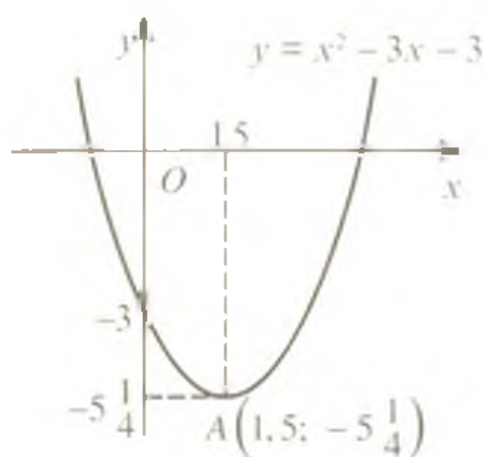

46-rasm

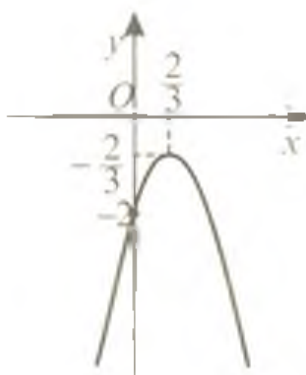

47-rasm

1-misol.  $y = x^2 - 3x - 3$  funksiyaning grafigini yasang.

Yechilishi. Kvadrat uchhadda to'la kvadratni ajratamiz:

$$y = x^2 - 3x - 3 = x^2 - 2 \cdot \frac{3}{2}x + \frac{9}{4} - \frac{9}{4} - 3 = (x - 1,5)^2 - 5,25.$$

Shunday qilib,  $y = (x - 1,5)^2 - 5,25$  parabola uchi  $A(1,5; -5,25)$  nuqtadan iborat. Uning simmetriya o'qi

$$x = 1,5$$

to'g'ri chiziq. Parabolani  $Oy$  o'qi bilan kesishish nuqtasining koordinatalarini topamiz:

$x = 0$  da  $y = 0^2 - 3 \cdot 0 - 3 = -3$ . Demak,  $(0; -3)$  koordinatali nuqta parabolani  $Oy$  o'qi bilan kesishish nuqtasi.

$a = 1 > 0$  bo'lganligi uchun parabola tarmoqlari yuqoriga yo'nalgan. Funksiya grafigi 46-rasmda tasvirlangan.

2-misol.  $y = -3x^2 + 4x - 2$  funksiya grafigini yasang.

Yechilishi. To'la kvadratni ajratamiz:

$$y = -3x^2 + 4x - 2 = -3\left(x - \frac{2}{3}\right)^2 - \frac{2}{3}.$$

Demak,  $\left(\frac{2}{3}; -\frac{2}{3}\right)$  koordinatali nuqta parabola uchi bo'ladi. Funksiya grafigi  $(0; -2)$  koordinatali nuqtada  $Oy$  o'qi bilan kesishadi.  $a = -3 < 0$  bo'lganligi uchun parabola tarmoqlari pastga yo'nalgan (47-rasm).

### Mustaqil ishlash uchun test topshiriqlari

- $x^2 = 3x$  tenglamani yeching.  
A) 0;      B) 3;      C) 0 va 3;      D)  $\pm 3$ ;      E) 3.
- $2x^2 + 4 = 0$  tenglama nechta ildizga ega?  
A) 2; B) 1; C) cheksiz ko'p; D) ildizlari yo'q; E) 3.
- $10(x - 2) + 19 = (5x - 1)(1 + 5x)$  tenglama ildizlarining o'rta arifmetigini toping.  
A) 0,2;      B) 2;      C) 2,5;      D) 4;      E) -0,4.
- $x^2 - 4\frac{1}{2}x + 4\frac{1}{2} = 0$  tenglamaning katta ildizidan kichik ildizining ayirmasi nechaga teng?  
A) 3;      B) 2,5;      C) 1,5;      D) -3;      E) -1,5.
- $\frac{x^3 - 8}{x - 2} = 8$  tenglamaning ildizlari yig'indisini toping.  
A) -2;      B) -4;      C) 4;      D)  $2\sqrt{5}$ ;      E)  $-2\sqrt{5}$ .

6\*.  $x_1$  va  $x_2$  lar  $(a-2)x^2 + (a+2)x - 2 = 0$  tenglamaning ildizlari va  $x_1 + x_2 = 1$  bo'lsa,  $a$  ni toping.

A) -3; B) 0; C) 2; D) 3; E) -2.

7.  $2x^2 - 20x + 32 = 0$  tenglama ildizlarining o'rta proporsionalini toping.

A) 8; B) 5; C) 6; D) 7; E) 4.

8.  $2000x^2 - 2002x + 2 = 0$  tenglama katta ildizining kichik ildiziga nisbatini toping.

A)  $\frac{2}{2000}$ ; B)  $-\frac{1}{1000}$ ; C) 1000; D) 1998; E)  $\frac{1}{1998}$ .

9.  $x^2 - bx + 6 = 0$  tenglamaning ildizlaridan biri 3 ga teng bo'lsa, tenglama koeffitsiyentlari yig'indisini toping.

A) 0; B) -2; C) 2; D) 12; E) -12.

10. Agar  $(x-4)\left(\frac{1}{4}x+3\right) = 0$  bo'lsa,  $\frac{1}{4}x+3$  qanday qiymatlar qabul qiladi?

A) 0; B) -12; C) 0 yoki 6; D) 0 yoki 4; E) -12 yoki 0.

11\*.  $b$  ning qanday qiymatida  $x^2 + \frac{3}{4}x + b$  uchhad to'la kvadrat bo'ladi?

A)  $\frac{1}{16}$ ; B)  $\frac{9}{64}$ ; C)  $\frac{9}{16}$ ; D)  $\frac{1}{4}$ ; E)  $\frac{3}{64}$ .

12.  $\frac{x^2+1}{x} + \frac{x}{x^2+1} = -2,5$  tenglama nechta ildizga ega?

A) 1; B) 2; C) 3; D) 4; E) tenglamaning ildizlari yo'q.

13.  $2\left(x^2 + \frac{4}{x^2}\right) + 3\left(x - \frac{2}{x}\right) - 13 = 0$  tenglama ildizlarining ko'paytmasini toping.

A) -8; B) 8; C) -4; D) 4; E) 1.

14.  $x^2 + 6x - 7 = 0$  tenglamaning kichik ildizini katta ildiziga nisbatini toping.

A) 6; B) -6; C)  $\frac{1}{7}$ ; D)  $-\frac{1}{7}$ ; E) -7.

15.  $\frac{x^2+5}{x} = 6$  tenglama ildizlarining o'rta arifmetigi ildizlari ko'paytmasidan qancha kam?

A) 5; B) 6; C) 2; D) -2; E) 8.

16.  $x + \frac{1}{3x} = 1$  tenglama nechta ildizga ega?

A) 1; B) 2; C) 3; D) 4; E) ildizlari yo'q.



17\*.  $k$  ning qanday qiymatlarida  $x^2 + 2(k - 4)x + k^2 + 2k + 3$  ifodani to'la kvadrat shaklida yozish mumkin?

- A)  $\frac{13}{10}$ ;    B)  $-\frac{13}{10}$ ;    C) 3;    D)  $\frac{13}{6}$ ;    E)  $-\frac{13}{6}$ .

18.  $x^2 - px + 6 = 0$  tenglamaning ildizlaridan biri 6 ga teng. Tenglamaning koeffitsiyentlari yig'indisini toping.

- A) 2;    B) 0;    C) 3;    D) 5;    E) 12.

19.  $x_1$  va  $x_2$  sonlar  $x^2 - 4x - 8 = 0$  tenglamaning ildizlari bo'lsa,  $\frac{1}{x_1^2} + \frac{1}{x_2^2}$  ning qiymatini toping.

- A) 2;    B) -2;    C)  $\frac{1}{2}$ ;    D)  $-\frac{1}{2}$ ;    E)  $\frac{3}{4}$ .

20.  $x^2 + x - 3 = 0$  tenglamaning ildizlari  $a$  va  $b$  sonlar bo'lsa,  $a^3 + b^3$  ning qiymatini toping.

- A) -1;    B) -3;    C) -27;    D) 10;    E) -10.

21\*.  $a$  ning qanday qiymatlarida  $x^2 - (\sqrt{2}a - 2)x - 4 = 0$  tenglamaning ildizlari qarama-qarshi sonlar bo'ladi?

- A) 1.5 va -1.5;    B)  $\sqrt{2}$  va  $-\sqrt{2}$ ;    C) 0;    D)  $\sqrt{2}$ ;    E) 4.

22\*.  $x^2 + px + 8 = 0$  tenglama ildizlari ayirmasining kvadrati 49 ga teng bo'lsa, ildizlarining yig'indisini toping.

- A) 8;    B) -8;    C)  $\pm 9$ ;    D) 0;    E) 9.

23.  $3x^2 + x - a = 0$  tenglamaning ildizlaridan biri 2 ga teng. Ikkinchi ildizining qiymatini toping.

- A) -3;    B)  $-2\frac{1}{3}$ ;    C) 3;    D)  $2\frac{1}{3}$ ;    E)  $\frac{1}{3}$ .

24.  $x_1$  va  $x_2$  sonlar  $3x^2 - 7x + 3 = 0$  tenglama ildizlari bo'lsa,  $x_1^3 + x_2^3$  ning qiymatini toping.

- A)  $5\frac{19}{27}$ ;    B)  $-5\frac{19}{27}$ ;    C)  $5\frac{4}{9}$ ;    D)  $-5\frac{4}{9}$ ;    E)  $5\frac{1}{3}$ .

25\*. Ildizlari  $x^2 + 6x + 8 = 0$  tenglamaning ildizlaridan 5 ga ortiq bo'lgan kvadrat tenglama tuzing.

- A)  $5x^2 + 30x + 40 = 0$ ;    B)  $x^2 + 11x + 8 = 0$ ;    C)  $x^2 + 6x + 5 = 0$ ;  
D)  $5x^2 + 6x + 8 = 0$ ;    E)  $x^2 - 4x + 3 = 0$ .

26\*. Ildizlari  $x^2 + px + q = 0$  tenglamaning ildizlaridan  $\frac{p}{2}$  qadar ortiq bo'lgan kvadrat tenglama tuzing.

- A)  $4x^2 + 4qx - p^2 = 0$ ;    B)  $x^2 + 4qx - p^2 = 0$ ;    C)  $4x^2 + 4q - p^2 = 0$ ;  
D)  $4x^2 - p^2x + 4q = 0$ ;    E)  $x^2 - p^2x + 4q = 0$ .

27.  $x^2 - 10x + 9$  kvadrat uchhadni ko'paytuvchilarga ajrating.

- A)  $(x-9)(x-1)$ ;      B)  $(x-3)(x+3)$ ;    C)  $(x-5)(x-3)$ ;  
 D)  $(x+1)(x-9)$ ;      E)  $(x+9)(x-1)$ .

28.  $5x^2 + 17x - 126$  kvadrat uchhadni ko'paytuvchilarga ajrating.

- A)  $(5x-18)(x+7)$ ;      B)  $5(x-18)(x+7)$ ;    C)  $5(x+18)(x-7)$ ;  
 D)  $(5x+18)(x-7)$ ;      E)  $(x+7)(x-18)$ .

29.  $\frac{x^2-4x-60}{x^2+25x+114}$  kasrni qisqartiring.

- A)  $\frac{x+10}{x+6}$ ;    B)  $\frac{x-10}{x-19}$ ;    C)  $\frac{x-10}{x+19}$ ;    D)  $\frac{x+6}{x+19}$ ;    E)  $\frac{x+6}{x-19}$ .

30.  $\frac{x^2-10x+9}{3x^2-2x-1}$  kasrni qisqartiring.

- A)  $\frac{x-1}{3x+1}$ ;    B)  $\frac{x-9}{x-1}$ ;    C)  $\frac{x-3}{x-1}$ ;    D)  $\frac{x-9}{3x+1}$ ;    E)  $\frac{x-9}{x+1}$ .

31.  $a$  ning qanday qiymatlarida  $4x^2 - 12x + a = 0$  tenglamaning ildizlari teng bo'ladi?

- A) 8;      B) 9;      C)  $\pm 8$ ;      D)  $\pm 9$ ;      E)  $\frac{1}{4}$ .

32.  $\frac{2a^2+8a-90}{3a^2-36a+105}$  kasrni qisqartiring.

- A)  $\frac{a+9}{a-7}$ ;    B)  $\frac{2(a+9)}{a-7}$ ;    C)  $\frac{a-5}{3(a-7)}$ ;    D)  $\frac{2(a+9)}{3(a-7)}$ ;    E)  $\frac{a+9}{a-5}$ .

33\*.  $x^4 + 4x^3 + 3x^2 - 2x - 1 = 0$  tenglamaning haqiqiy ildizlari ko'paytmasini toping.

- A)  $\frac{-3+\sqrt{13}}{2}$ ;    B)  $\frac{-3-\sqrt{13}}{4}$ ;    C)  $-1$ ;    D)  $5\frac{1}{2}$ ;    E)  $1$ .

34\*.  $x^4 + 4x^3 - 10x^2 - 28x - 15 = 0$  tenglamaning eng katta va eng kichik ildizlari ayirmasini toping.

- A) 8;      B)  $-3$ ;      C)  $-8$ ;      D)  $-4$ ;      E) 4.

35.  $x^4 - 13x^2 + 36 = 0$  tenglamaning barcha ildizlari yig'indisini toping.

- A) 5;      B)  $-5$ ;    C) 1; D)  $-1$ ;      E) 0.

36.  $x^4 + 26x^2 - 360 = 0$  tenglamaning haqiqiy ildizlarini toping.

- A) 10; B)  $-10$ ; C)  $\sqrt{10}$ ; D)  $\sqrt{10}$  va  $-\sqrt{10}$ ; E) haqiqiy ildizlari yo'q.

37.  $\frac{x+3}{5x+2} + \frac{5x+2}{x+3} = \frac{13}{6}$  tenglamaning ildizlarini toping.

- A) 0;      B)  $\frac{2}{3}$ ;    C)  $\frac{3}{2}$ ;      D) 0 va  $\frac{5}{7}$ ;    E)  $\frac{2}{3}$  va  $\frac{3}{2}$ .

38\*.  $x^4 - 10x^3 + 26x^2 - 10x + 1 = 0$  tenglamaning ildizlari yig'indisini toping.

D) 34 km/soat; E) 36 km/soat.

53\*. Bir portdan paroxodlardan biri janubga, ikkinchisi g'arbga qarab ketdi. 2 soatdan keyin ular orasidagi masofa 60 km ga teng bo'ldi. Paroxodlardan birining tezligi ikkinchisining tezligidan 6 km/soat ortiq bo'lsa, har qaysi paroxod tezligini toping.

A) 18 va 24; B) 30 va 36; C) 28 va 36; D) 20 va 26; E) 25 va 31.

54. Daryo bo'yida joylashgan ikki shahar orasidagi masofa 80 km. Paroxod bir shahardan daryo oqimi bo'ylab ikkinchi shaharga borib, orqaga qaytib kelishi uchun 8 soat 20 minut vaqt sarfladi. Daryo oqimining tezligi 4 km/soat. Paroxodning turg'un suvdagi tezligini toping.

A) 20; B) 24; C) 25; D) 28; E) 30.

55. Ishchi o'ziga topshirilgan ishni bajarayotganda har kuni rejadagidan 2 ta ortiq detal tayyorlasa, ishni muddatidan 3 kun ilgari tugatadi; agar rejadagidan 4 ta ortiq tayyorlasa, muddatidan 5 kun ilgari tugatadi. Ishchi nechta detal tayyorlashi va necha kunda tayyorlashi kerak?

A) 80; 8; B) 100; 10; C) 120; 12; D) 120; 15; E) 90; 16.

56.  $y = 2x^2 + 4x - 6$  parabola uchining koordinatalarini toping.

A) (0; -6); B) (-1; 8); C) (8; -1); D) (-6; 0); E) (2; 2)

57.  $y = x^2 - 4x + 4$  parabolaning simmetriya o'qi koordinatalar boshidan necha birlik masofada joylashgan?

A) 1; B) 2; C) 3; D) 2.5; E) 4.

58. Agar  $a < 0$ ,  $b^2 - 4ac = 0$  bo'lsa,  $y = ax^2 + bx + c$  funksiyaning grafigi koordinatalar tekisligining qaysi choraklarida joylashadi?

A) I va II; B) II va IV; C) III va IV;

D) II va III; E) I, II, III va IV.

59. Agar  $a > 0$ ,  $b^2 - 4ac < 0$  bo'lsa,  $y = ax^2 + bx + c$  funksiyaning grafigi koordinatalar tekisligining qaysi choraklarida joylashadi?

A) I, II va III; B) III va IV; C) I, II, III va IV;

D) II va III; E) I va II.

60.  $y = x^2 + 7x + 15$  funksiya grafigi koordinatalar tekisligining qaysi choraklarida joylashadi?

A) I va II; B) I, II va III; C) I va IV;

D) II va III; E) III va IV.

61\*.  $a$  ning qanday qiymatlarida  $y = ax^2 + 16ax + 68a$  parabola grafigi  $Ox$  o'qidan yuqorida yotmaydi?

A) (0; 4); B)  $(-\infty; -4)$ ; C)  $(-\infty; -4) \cup (4; +\infty)$ ;

D)  $(-\infty; 0)$ ; E)  $(-4; 0)$ .

62.  $N(1; 9)$  nuqta  $y = -x^2 + ax + 4$  parabola grafigiga tegishli. Parabola uchining ordinatasini toping.

A) 13;      B) 6;      C) 4;      D) 2;      E) 7.

63\*.  $k$  ning qanday qiymatida  $y = x^2 - 4x + 12 - k$  parabolaning uchi  $A(2; 4)$  nuqtada yotadi?

A) 6;      B) 5;      C) 4;      D) 3;      E) 2.

64\*.  $a$  ning qanday qiymatida  $ax^2 + 2(a + 3)x + a + 2 = 0$  tenglamaning ildizlari nomanfiy bo'ladi?

A)  $[-2.1; -1]$ ;      B)  $[1; 2]$ ;      C)  $(-\infty; -2]$ ;      D)  $[-2.25; -2]$ ;

E)  $a$  ning bunday qiymatlari yo'q.

65.  $\frac{x^2 - x - 2}{x^2 + x} = 0$  tenglamaning ildizlari nechta?

A) 4;      B) 3;      C) 2;      D) 1;      E) ildizlari yo'q.

shaklda tasvirlanadi. Parabola grafigi  $Ox$  o'qiga absissasi  $-\frac{b}{2a}$  bo'lgan nuqtada urinadi (50-rasm). Shuning uchun  $ax^2 + bx + c > 0$  tengsizlik  $x$  ning  $x = -\frac{b}{2a}$  dan boshqa barcha qiymatlarida bajariladi, ya'ni  $x \in \left(-\infty; -\frac{b}{2a}\right) \cup \left(-\frac{b}{2a}; +\infty\right)$ .  $ax^2 + bx + c \geq 0$  tengsizlik esa  $x$  ning har qanday qiymatida bajariladi, ya'ni  $x \in R$ . Bu holda  $ax^2 + bx + c < 0$  tengsizlik yechimga ega bo'lmaydi,  $ax^2 + bx + c \leq 0$  tengsizlik esa yagona  $x = -\frac{b}{2a}$  nuqtada bajariladi.

Agar  $a < 0$  bo'lsa, kvadrat tengsizlikning har ikkala qismini  $(-1)$  ga ko'paytirib, yuqorida bayon qilingan uchta holdan biriga keltirilib yechiladi.

1-misol.  $3x^2 - 11x - 4 > 0$  tengsizlikni yeching.

Yechilishi. Berilgan tengsizlikning chap qismidagi kvadrat uchhadda

$$a = 3 > 0; D = b^2 - 4ac = 121 + 48 = 169 > 0;$$

$$x_1 = \frac{11-13}{6} = -\frac{1}{3}; x_2 = \frac{11+13}{6} = 4.$$

Demak,  $3x^2 - 11x - 4$  parabola grafigi  $\left(-\infty; -\frac{1}{3}\right)$  va  $(4; +\infty)$  oraliqlarda  $Ox$  o'qidan yuqorida joylashgan bo'ladi (51-rasm) va berilgan tengsizlik  $x$  ning shu oraliqlarga tegishli har qanday qiymatida bajariladi.

Javob:  $x \in \left(-\infty; -\frac{1}{3}\right) \cup (4; \infty)$ .

2-misol.  $-9x^2 + 12x - 4 < 0$  tengsizlikni yeching.

Yechilishi.  $-9x^2 + 12x - 4 < 0 \Leftrightarrow 9x^2 - 12x + 4 > 0$ .

Berilgan tengsizlikka teng kuchli  $9x^2 - 12x + 4 > 0$  tengsizlikning chap qismidagi kvadrat uchhadda

$$a = 9 > 0; D = 144 - 144 = 0.$$

$$x_1 = x_2 = \frac{2}{3}.$$

Bu kvadrat uchhadning grafigi  $Ox$  o'qidan yuqorida joylashgan bo'lib, absissalar o'qiga  $x = \frac{2}{3}$  nuqtada urinadi. Shu sababli berilgan tengsizlik  $x$  ning  $x = \frac{2}{3}$  nuqtadan boshqa barcha qiymatlarida bajariladi.

J a v o b:  $x \in (-\infty; \frac{2}{3}) \cup (\frac{2}{3}; +\infty)$ .

3- m i s o l.  $7x^2 - 10x + 7 > 0$  tengsizlikni yeching.

Y e c h i l i s h i. Tengsizlikning chap qismidagi kvadrat uchhadda  
 $a = 7 > 0$ ;  $D = 100 - 4 \cdot 7 \cdot 7 = -96 < 0$ .

Parabola grafiği butunlay  $Ox$  o'qidan yuqorida yotadi. Shu sababli tengsizlik  $x$  ning har qanday qiymatida bajariladi.

J a v o b:  $x \in (-\infty; +\infty)$ .

## 2-§. Tengsizliklarni yechishning oraliqlar usuli

Ushbu

$$f(x) = (x + 2)(x - 3)(x - 5)$$

funksiyani qaraylik. Bu funksiya sonlar o'qining barcha nuqtalarida aniqlangan.  $x$  ning  $-2, 3, 5$  ga teng qiymatlarida funksiya qiymati nolga teng bo'ladi. Bu sonlar funksiyaning aniqlanish sohasini  $(-\infty; -2); (-2; 3); (3; 5); (5; +\infty)$  oraliqlarga ajratadi (52-rasm).

$(x + 2)(x - 3)(x - 5)$  ifoda 3 ta ko'paytuvchidan iborat bo'lib, ularning har birining ko'rsatilgan oraliqlardagi ishorasi quyidagi jadvalda keltirilgan:

	$(-\infty; -2)$	$(-2; 3)$	$(3; 5)$	$(5; +\infty)$
$x + 2$	-	+	+	+
$x - 3$	-	-	+	+
$x - 5$	-	-	-	+

Jadvaldan ko'rinib turibdiki,

agar  $x \in (-\infty; -2)$  bo'lsa,  $f(x) < 0$ ;

agar  $x \in (-2; 3)$  bo'lsa,  $f(x) > 0$ ;

agar  $x \in (3; 5)$  bo'lsa,  $f(x) < 0$ ;

agar  $x \in (5; +\infty)$  bo'lsa,  $f(x) > 0$ .

Shunday qilib, funksiya bu oraliqlarning har birida o'z ishorasini saqlaydi.  $x = -2$ ;  $x = 3$  va  $x = 5$  nuqtalardan o'tayotganda esa ishorasini o'zgartiradi (53-rasm).

Umuman, agar funksiya

$$f(x) = (x - x_1)(x - x_2)(x - x_3) \dots (x - x_{n-1})(x - x_n)$$

formula bilan berilgan bo'lsa (bunda  $x_1, x_2, x_3, \dots, x_{n-1}, x_n$  — bir-biriga teng bo'lmagan sonlar), funksiya sonlar o'qining  $x_1, x_2, \dots, x_n$



52-rasm



53-rasm



54-rasm

sonlar ajratadigan oraliqlarida o'z ishorasini saqlaydi va bu nuqtalardan o'tayotganda ishorasini o'zgartiradi. Bu xususiyatdan

$$(x - x_1)(x - x_2) \dots (x - x_n) > 0,$$

$$(x - x_1)(x - x_2) \dots (x - x_n) < 0 \quad (1)$$

ko'rinishidagi tengsizliklarni yechishda foydalaniladi. Shunga doir bir necha misollar keltiramiz.

1-misol.  $(x + 6)(x + 1)(x - 4) > 0$  tengsizlikni yeching.

Yechilishi. Har bir chiziqli ko'paytuvchi nolga aylanadigan nuqtalarni sonlar o'qida belgilab, uni  $(-\infty; -6)$ ,  $(-6; -1)$ ,  $(-1; 4)$  va  $(4; +\infty)$  oraliqlarga ajratamiz.

Bu oraliqlarning har birida tengsizlikning chap qismidagi ko'paytma ishorasini aniqlaymiz (54-rasm). Rasmdan ko'rinib turibdiki, tengsizlik  $x$  ning  $(-6; -1)$  va  $(4; +\infty)$  oraliqlardagi barcha qiymatlarida bajariladi.

Javob:  $x \in (-6; -1) \cup (4; +\infty)$ .

Tengsizliklarni yechishning bu usuli *oraliqlar usuli* deyiladi.

2-misol.  $x(0,5 - x)(x + 4) \leq 0$  tengsizlikni yeching.

Yechilishi. Berilgan tengsizlikni  $(-1)$  ga ko'paytirib, (1) ko'rinishiga keltiramiz:

$$x(x - 0,5)(x + 4) \geq 0.$$

Ko'paytuvchilarning har biri nolga aylanadigan  $x_1 = 0$ ;  $x_2 = 0,5$ ;  $x_3 = -4$  nuqtalar sonlar o'qini  $(-\infty; -4)$ ,  $[-4; 0]$ ,  $(0; 0,5)$  va  $[0,5; +\infty)$  oraliqlarga ajratadi. Bu oraliqlarda ko'paytma isho-

rasini aniqlaymiz (55-rasm). Ghizmadan ko'rinib turibdiki, tengsizlikning yechimi  $[-4; 0]$  va  $[0.5; +\infty)$  oraliqlar birlashmasidan iborat.



55-rasm



56-rasm

J a v o b:

$$x \in [-4; 0] \cup [0.5; +\infty).$$

3-misol.  $\frac{7-x}{x+2} \leq 0$  tengsizlikni yeching.

Yechilishi.  $\frac{7-x}{x+2}$  kasr ishorasi  $(7-x)(x+2)$  ko'paytma ishorasi bilan bir xil bo'lganligi sababli berilgan tengsizlik

$$(7-x)(x+2) \leq 0 \quad (x \neq -2)$$

tengsizlikka teng kuchlidir.  $(7-x)(x+2) \leq 0$  tengsizlikni (1) tengsizlik ko'rinishiga keltiramiz:

$$(7-x)(x+2) \leq 0 \Leftrightarrow (x-7)(x+2) \geq 0. \quad (\Lambda)$$

Sonlar o'qini oraliqlarga ajratamiz va bu oraliqlarda ko'paytma ishorasini aniqlaymiz (56-rasm).

(A) tengsizlikning va unga teng kuchli bo'lgan

$$\frac{7-x}{x+2} \leq 0$$

tengsizlikning yechimlarining to'plami  $(-\infty; -2)$  va  $[7; +\infty)$  oraliqlar birlashmasidan iborat.

J a v o b:  $x \in (-\infty; -2) \cup [7; +\infty)$ .

Umuman,

$$\frac{(x-x_1)(x-x_2)\dots(x-x_k)}{(x-x_p)(x-x_q)\dots(x-x_m)} > 0,$$

$$\frac{(x-x_1)(x-x_2)\dots(x-x_k)}{(x-x_p)(x-x_q)\dots(x-x_m)} < 0 \quad (2)$$

$$(x \neq x_p, x \neq x_q, \dots, x \neq x_m)$$

ko'rinishidagi tengsizliklarni yechishda sonlar o'qini kasr suratidagi va maxrajidagi ko'paytuvchilarning har birining nollari bilan



oraliqlarga ajratib, bu oraliqlarda kasr ifodaning ishorasini aniqlash yordamida oraliqlar usuli bilan yechimlar to'plamini ko'rsatish mumkin.

4-m i s o l. 
$$\frac{(-x^2+x-1)(x^2+x-2)}{x^2-7x+12} \geq 0$$
 tengsizlikning butun

yechimlari nechta?

Y e c h i l i s h i. 
$$\frac{(-x^2+x-1)(x^2+x-2)}{x^2-7x+12} \geq 0 \Leftrightarrow \frac{(x^2-x+1)(x^2+x-2)}{x^2-7x+12} \leq 0 \Leftrightarrow$$

$$\Leftrightarrow \frac{(x^2-x+1)(x+2)(x-1)}{(x-3)(x-4)} \leq 0.$$

Berilgan tengsizlikka teng kuchli bo'lgan bu tengsizlikdagi  $x^2 - x + 1$  kvadrat uchhad  $x$  ning har qanday qiymatida ham musbat qiymatlar qabul qiladi ( $a = 1 > 0$ ;  $D = 1 - 4 = -3 < 0$ ). Buni e'tiborga olsak, berilgan tengsizlik

$$\frac{(x+2)(x-1)}{(x-3)(x-4)} \leq 0 \quad (\text{B})$$

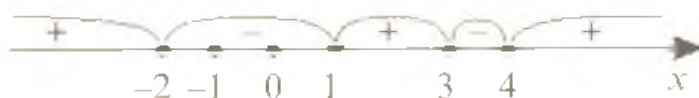

57-rasm

tengsizlikka teng kuchli bo'ladi. Sonlar o'qini oraliqlarga ajratib (B) tengsizlikdagi kasr ifoda ishoralarini aniqlaymiz (57-rasm).

Berilgan tengsizlikning yechimlari to'plami  $[-2; 1]$  va  $(3; 4)$  oraliqlar birlashmasidan iborat. Bu oraliqlarga tegishli butun sonlar  $-2, -1, 0$  va  $1$ . Demak, tengsizlikning butun yechimlari soni 4 ta ekan.

J a v o b: 4 ta.

5-m i s o l. 
$$\begin{cases} x^2 + x - 6 < 0, \\ -x^2 + 2x + 3 \leq 0 \end{cases}$$
 tengsizliklar sistemasini yeching.

Y e c h i l i s h i.

$$\begin{cases} x^2 + x - 6 < 0, \\ -x^2 + 2x + 3 \leq 0 \end{cases} \Leftrightarrow \begin{cases} x^2 + x - 6 < 0, \\ x^2 - 2x - 3 \geq 0 \end{cases} \Leftrightarrow \begin{cases} (x+3)(x-2) < 0, \\ (x-3)(x+1) \geq 0. \end{cases}$$

Sistemaning har bir tengsizligining yechimlar to'plamini oraliq-

lar usuli bilan topamiz.

58-rasmda

$$(x + 3)(x - 2) < 0,$$

59-rasmda esa

$(x - 3)(x + 1) \geq 0$  yechimlari to'plamlari tasvirlangan.

Sistemaning birinchi tengsizligi  $x \in (-3; 2)$  oraliqda, ikkinchi tengsizligi

$$x \in (-\infty; -1] \text{ va}$$

$x \in [3; +\infty)$  oraliqlarda bajariladi.

Sistemaning yechimini topish uchun har bir tengsizlikning yechimlari to'plamini bitta chizmada tasvirlaymiz (60-rasm).

Yechimlar to'plamining kesishmasidan iborat

$(-3; -1]$  oraliq berilgan tengsizliklar sistemasining yechimi bo'ladi.

J a v o b:  $(-3; 1]$ .

6-misol.

$$\begin{cases} x^2 + x - 6 > 0, \\ x^2 + x + 6 > 0 \end{cases} \text{ tengsizliklar sistemasini yeching.}$$

Yechilishi. Tengsizliklar sistemasidagi  $x^2 + x - 6$  kvadrat uchhadning ildizlari  $x_1 = -3; x_2 = 2$ .  $x^2 + x + 6$  kvadrat uchhadga esa  $a = 1 > 0$ ,  $D = 1 - 24 = -23 < 0$ . Demak,  $x^2 + x - 6 > 0$  tengsizlik  $x \in (-\infty; -3)$  va  $x \in (2; +\infty)$  oraliqlarda bajariladi,  $x^2 + x + 6 > 0$  tengsizlik esa  $x$  ning har qanday qiymatida o'rinli. Sonlar o'qida berilgan tengsizliklar sistemasini qanoatlantiriladigan sonlar to'plamini tasvirlaymiz (61-rasm).

J a v o b:  $x \in (-\infty; -3) \cup (2; +\infty)$ .



58-rasm



59-rasm

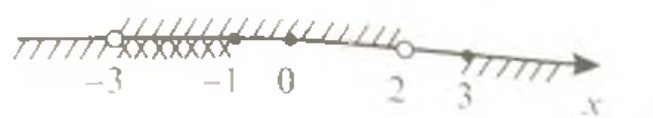

60-rasm

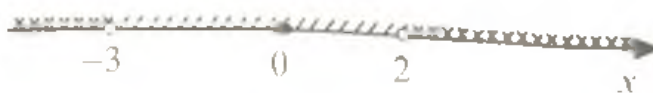

61-rasm

### 3-§. Irratsional tenglamalar

Noma'lumlari ildiz belgisi ostida bo'lgan tenglamalar irratsional tenglamalar deyiladi. Masalan, quyidagi tenglamalar irratsional tenglamalarga misol bo'la oladi:

$$\sqrt{x+6} = 2, \sqrt{x-1} = 3 + \sqrt{x}, \sqrt[5]{1-3x} = 3, \sqrt[4]{x-5} - \sqrt{x-5} = \sqrt{7-x}.$$

**3.1. Irratsional tenglamalarning chet ildizlari.** Irratsional tenglamalarni yechishda asosan ikki usul qo'llaniladi: tenglamaning ikkala tomonini bir xil darajaga ko'tarish usuli; yangi o'zgaruvchilar kiritish usuli. Bu usullar bilan irratsional tenglamadan ratsional tenglamaga o'tiladi. Agar tenglamaning har ikkala tomoni toq darajaga ko'tarilsa, berilgan tenglamaga teng kuchli tenglama hosil bo'ladi. Agar tenglamaning har ikki tomoni juft darajaga ko'tarilsa, **chet ildizlar** (berilgan tenglamani qanoatlantirmaydigan ildizlar) hosil bo'lishi mumkin.

$n \in N$  uchun  $\sqrt[2n]{f(x)} = \varphi(x)$  tenglama

$$\begin{cases} f(x) = (\varphi(x))^{2n}, \\ \varphi(x) \geq 0 \end{cases}$$

tenglamalar sistemasiga teng kuchlidir. Bu teng kuchlilik arifmetik ildiz tushunchasiga asoslangan.

O'zgaruvchi  $x$  ning berilgan irratsional tenglama ma'noga ega bo'ladigan barcha qiymatlari to'plami tenglamaning aniqlanish sohasi deyiladi. Masalan,

$$\sqrt{x-1} = 2x-3$$

tenglamaning aniqlanish sohasi o'zgaruvchi  $x$  ning

$$\begin{cases} x-1 \geq 0, \\ 2x-3 \geq 0 \end{cases}$$

tengsizliklarni qanoatlantiruvchi qiymatlar to'plami  $[1.5; +\infty)$  oraliqdan iborat.

$\sqrt{x-1} = 2x-3$  tenglamaning ildizlarini topish quyidagicha bajariladi:

$$\sqrt{x-1} = 2x-3 \Rightarrow \begin{cases} x-1 = (2x-3)^2, \\ 2x-3 \geq 0 \end{cases} \Leftrightarrow \begin{cases} x-1 = 4x^2 - 12x + 9, \\ x \geq 1,5 \end{cases} \Leftrightarrow$$

$$\Leftrightarrow \begin{cases} 4x^2 - 13x + 10 = 0 \\ x \geq 1,5 \end{cases} \Rightarrow \begin{cases} x_{1,2} = \frac{13 \pm \sqrt{169-160}}{8} \\ x \geq 1,5 \end{cases} \Rightarrow \begin{cases} x_1 = 1,25 \\ x_2 = 2 \end{cases} \Rightarrow [x = 2.$$

Tekshirish yordamida  $x_1 = 1,25$  ildiz berilgan tenglamani qanoatlantirmasligiga, ikkinchi  $x_2 = 2$  ildiz esa uni qanoatlantirishiga ishonch hosil qilish mumkin.

**Tekshirish.**

Agar  $x_1 = 1,25$  bo'lsa, u holda

$$\sqrt{1,25-1} \neq 2 \cdot 1,25 - 3.$$

Agar  $x_2 = 2$  bo'lsa, u holda

$$\sqrt{2-1} = 2 \cdot 2 - 3.$$

Shunday qilib,  $x_1 = 1,25$  chet ildiz (u tenglamani qanoatlantirmaydi).  $x_2 = 2$  tenglama ildizi (u tenglamani qanoatlantiradi). Irratsional tenglamalar har ikkala qismini darajaga ko'tarish usuli bilan yechilsa, topilgan ildizlar albatta tekshirilib ko'rilishi shart.

### 3.2. Irratsional tenglamalarni yechishga doir misollar.

1-misol.  $\sqrt{x-2} + \sqrt{1-x} = 3$  tenglamani yeching.

**Yechilishi.** Nomanfiy sonlardangina kvadrat ildiz chiqarish mumkinligidan noma'lum  $x$  miqdorning qabul qilishi mumkin bo'lgan qiymatlari

$$\begin{cases} x-2 \geq 0, \\ 1-x \geq 0 \end{cases}$$

tengsizliklar sistemasini qanoatlantirishi kerak. Bu sistemada  $x \geq 2$  va  $x \leq 1$  tengsizliklar bir vaqtda bajarilmasligi ravshan. Shuning uchun  $x$  noma'lum miqdorning qabul qilishi mumkin bo'lgan qiymatlar to'plami bo'sh. Demak, tenglama haqiqiy ildizlarga ega emas.

**Javob:** tenglamaning ildizlari yo'q.

Ko'rib chiqilgan misol irratsional tenglamani yechishdan avval noma'lum miqdorning qabul qilishi mumkin bo'lgan qiymatlar to'plami bo'sh emasligini tekshirish kerakligini ko'rsatadi. Agar bu to'plam bo'sh bo'lsa, darhol tenglama ildizlarga ega emas deyiladi.

2-misol.  $\sqrt{x-2} + \sqrt{4-x} = \sqrt{6-x}$  tenglamani yeching.

Yechilishi. Noma'lum  $x$  ning qabul qilishi mumkin bo'lgan qiymatlari to'plamini aniqlaymiz:

$$\begin{cases} x-2 \geq 0, \\ 4-x \geq 0, \\ 6-x \geq 0 \end{cases} \Leftrightarrow \begin{cases} x \geq 2, \\ x \leq 4, \\ x \leq 6 \end{cases} \Rightarrow [2 \leq x \leq 4].$$

Tenglamani  $[2; 4]$  kesmaga tegishli ildizlarini topish uchun uning har ikkala qismini kvadratga ko'taramiz:

$$(\sqrt{x-2} + \sqrt{4-x})^2 = (\sqrt{6-x})^2 \Leftrightarrow x-2 + 2\sqrt{(x-2)(4-x)} + 4-x = 6-x \Leftrightarrow$$

$$\Leftrightarrow 2\sqrt{(x-2)(4-x)} = 4-x \Leftrightarrow \left(2\sqrt{-x^2+6x-8}\right)^2 = (4-x)^2 \Leftrightarrow$$

$$\Leftrightarrow 4(-x^2+6x-8) = 16-8x+x^2 \Leftrightarrow 5x^2-32x+48=0 \Rightarrow$$

$$\Rightarrow x_{1,2} = \frac{16 \pm \sqrt{256-240}}{5} \Rightarrow \begin{cases} x_1 = 2,4, \\ x_2 = 4. \end{cases}$$

Topilgan har ikkala ildiz ham tenglamani aniqlanish sohasiga tegishli.

Javob: 2,4 va 4.

3-misol.  $\sqrt{2x-1} - 2\sqrt[4]{2x-1} = 3$  tenglamani yeching.

Yechilishi. Noma'lum  $x$  ning qabul qilishi mumkin bo'lgan qiymatlari to'plamini aniqlaymiz:

$$2x-1 \geq 0 \Rightarrow x \geq 0,5.$$

Berilgan tenglamani yangi o'zgaruvchi kiritish usuli bilan yechamiz:  $\sqrt[4]{2x-1} = y (y \geq 0)$  almashtirishni bajarsak, tenglama

$$y^2 - 2y - 3 = 0$$

ko'rinishga keladi. Bu tenglamani ildizlari  $y_1 = -1$ ,  $y_2 = 3$ .  $y \geq 0$  bo'lganligi uchun  $y_1 = -1$  chet ildiz. Shunday qilib,

$$\sqrt[4]{2x-1} = 3 \Leftrightarrow (\sqrt[4]{2x-1})^4 = 3^4 \Leftrightarrow 2x-1 = 81 \Rightarrow 2x = 82 \Rightarrow [x = 41.$$

Tekshirish.  $\sqrt{2 \cdot 41 - 1} = 2\sqrt[4]{2 \cdot 41 - 1} = 9 - 6 = 3.$

J a v o b: 41.

4-misol.  $\sqrt[3]{5-x} + \sqrt[3]{x+5} = 1$  tenglamani yeching.

Y e c h i l i s h i. Berilgan tenglamada noma'lum  $x$  ning qabul qilishi mumkin bo'lgan to'plami haqiqiy sonlar to'plamidan iborat, ya'ni  $x \in \mathbb{R}$ . Tenglamani har ikkala qismini

$$(a+b)^3 = a^3 + b^3 + 3ab(a+b)$$

ayniyatdan foydalanib kubga ko'taramiz:

$$5-x+x+5 + 3\sqrt[3]{(5-x)(x+5)} (\sqrt[3]{5-x} + \sqrt[3]{x+5}) = 1.$$

Tenglama shartiga ko'ra  $\sqrt[3]{5-x} + \sqrt[3]{x+5} = 1$  ekanligini e'tiborga olib,

$$10 + 3\sqrt[3]{25-x^2} = 1 \Leftrightarrow \sqrt[3]{25-x^2} = -3$$

tenglamani hosil qilamiz. Hosil qilingan tenglamaning har ikkala qismini yana kubga ko'taramiz:

$$\left(\sqrt[3]{25-x^2}\right)^3 = (-3)^3 \Leftrightarrow 25-x^2 = -27 \Rightarrow x^2 - 52 = 0 \Leftrightarrow$$

$$\Leftrightarrow (x - \sqrt{52})(x + \sqrt{52}) = 0 \Rightarrow \begin{cases} x_1 = -\sqrt{52}, \\ x_2 = \sqrt{52}. \end{cases}$$

J a v o b:  $-\sqrt{52}$  va  $\sqrt{52}$ .

#### 4-§. Irratsional tengsizliklar

4.1. Irratsional tengsizlik tushunchasi. *O'zgaruvchisi ildiz belgisi ostida bo'lgan tengsizliklar irratsional tengsizliklar deyiladi.* Bunday tengsizliklarni yechishning asosiy usuli darajaga ko'tarish usuli bo'lib, bunda irratsional tengsizliklarni yechish ratsional tengsizliklarni yoki ratsional tengsizliklar sistemalarini yechishga keltiriladi. Irratsional tengsizliklarni yechishda quyidagi teoremlardan foydalaniladi:

1-teorema.  $n \in N$  bo'lganda

$$\sqrt[n]{f(x)} < \varphi(x)$$

tengsizlik

$$\begin{cases} f(x) \geq 0, \\ \varphi(x) > 0, \\ f(x) < (\varphi(x))^{2n} \end{cases}$$

tengsizliklar sistemasiga teng kuchlidir.

2-teorema.  $n \in N$  bo'lganda

$$\sqrt[n]{f(x)} > \varphi(x)$$

tengsizlik

$$\begin{cases} \varphi(x) < 0, \\ f(x) \geq 0, \end{cases} \text{ va } \begin{cases} \varphi(x) \geq 0, \\ f(x) > (\varphi(x))^{2n} \end{cases}$$

tengsizliklar sistemalarining birlashmasiga teng kuchlidir.

3-teorema.  $n \in N$  bo'lganda

$$\frac{\sqrt[n]{f(x)}}{\varphi(x)} > 1$$

tengsizlik

$$\begin{cases} \varphi(x) > 0, \\ f(x) > (\varphi(x))^{2n} \end{cases}$$

tengsizliklar sistemasiga teng kuchlidir.

4-teorema.  $n \in N$  bo'lganda

$$\frac{\sqrt[n]{f(x)}}{\varphi(x)} < 1$$

tengsizlik

$$\begin{cases} \varphi(x) < 0, \\ f(x) \geq 0, \end{cases} \text{ va } \begin{cases} \varphi(x) > 0, \\ f(x) \geq 0, \\ f(x) < (\varphi(x))^{2n} \end{cases}$$

tengsizliklar sistemalarining birlashmasiga teng kuchlidir.

## 4.2. Irratsional tengsizliklarni yechilishiga doir misollar

1-misol.  $\sqrt{x} > -3$  tengsizlikni yeching.

Yechilishi. O'zgaruvchi  $x$  ning qabul qilishi mumkin bo'lgan qiymatlari  $x \geq 0$  shartni qanoatlantirishi kerak. Tengsizlikning chap tomoni manfiy bo'lganligi sababli uning yechimi  $x \geq 0$  bo'ladi.

Javob:  $x \in [0; +\infty)$ .

2-misol.  $\sqrt{x^2 + 3x} > 2$  tengsizlikni yeching.

$$\text{Yechilishi. } \sqrt{x^2 + 3x} > 2 \Leftrightarrow \begin{cases} x^2 + 3x \geq 0, \\ x^2 + 3x > 4 \end{cases} \Leftrightarrow$$

$$\Leftrightarrow x^2 + 3x - 4 > 0 \Leftrightarrow (x+4)(x-1) > 0.$$

Berilgan tengsizlikka teng kuchli bo'lgan



$(x+4)(x-1) > 0$ .

tengsizlik o'zgaruvchi

$x$  ning  $(-\infty; -4)$  va

$(1; +\infty)$  oraliqlarga tegishli barcha qiymatlarida bajariladi (62-rasm).

62-rasm

Javob:  $(-\infty; -4) \cup (1; \infty)$ .

3-misol.  $\sqrt{x^2 - 7x} > -2$  tengsizlikni yeching.

Yechilishi. Tengsizlikning o'ng qismi manfiy sondan iborat bo'lgan bunday tengsizliklarni yechishda faqat juft darajali ildiz ostidagi ifodaning nomanfiy bo'lishi shartligini hisobga olish yetarlidir, chunki irratsional tenglama va tengsizliklarda ildizning faqat arifmetik qiymati qaraladi. Shu sababli berilgan tengsizlik

$$x^2 - 7x \geq 0$$

tengsizlikka teng kuchlidir. Shu tengsizlikni oraliqlar usuli bilan yechamiz:

$$x^2 - 7x \geq 0 \Leftrightarrow x(x-7) \geq 0$$

Javob:  $x \in (-\infty; 0] \cup [7; +\infty)$  (63-rasm).

4-misol.  $\sqrt{3x-1} < 3$  tengsizlikning butun yechimlari nechta?



63-rasm



Yechilishi.

$$\sqrt{3x-1} < 3 \Leftrightarrow \begin{cases} 3x-1 \geq 0 \\ 3x-1 < 3^2 \end{cases} \Leftrightarrow \begin{cases} x \geq \frac{1}{3} \\ x < \frac{10}{3} \end{cases} \Leftrightarrow \frac{1}{3} \leq x < \frac{10}{3}.$$

Berilgan tengsizlik o'zgaruvchi  $x$  ning  $\left[\frac{1}{3}; \frac{10}{3}\right)$  oraliqqa tegishli barcha qiymatlarida bajariladi. Bu oraliqdagi butun sonlar 1; 2; 3.

J a v o b: 3 ta.

5- m i s o l.  $\sqrt{x-1} < 3-x$  tengsizlikni yeching.

Yechilishi. Tengsizlikni yechishda 1-teoremadan foydalanamiz. Tengsizlikning chap qismi  $x-1 \geq 0$  bo'lganda ma'noga ega. Tengsizlikning mohiyatiga ko'ra  $3-x > 0$  bo'lishi kerak. Bu shartlar bajarilganda tengsizlikning ikkala qismi ham nomanfiy bo'ladi, demak, kvadratga ko'tarish usulidan foydalanish mumkin. Shunday qilib, berilgan tengsizlik quyidagi tengsizliklar sistemasiga teng kuchli:

$$\begin{cases} x-1 \geq 0, \\ 3-x > 0, \\ x-1 < (3-x)^2. \end{cases}$$

$$\text{Bundan } \begin{cases} x \geq 1, \\ x < 3, \\ (x-2)(x-5) > 0 \end{cases} \Rightarrow [1 \leq x < 2).$$

Sistemaning yechimlar kesishmasi (64-rasmda) tasvirlangan.

J a v o b:  $x \in [1; 2)$ .

6-m i s o l.  $\sqrt{x-1} > 3-x$  tengsizlikning eng kichik butun yechimini toping.

Y e c h i l i s h i. Tengsizlikni yechishda 2-teoremadan foydalanamiz. Berilgan tengsizlik



64-rasm



65-rasm

$$a) \begin{cases} 3-x < 0, \\ x-1 \geq 0 \end{cases} \text{ va } b) \begin{cases} 3-x \geq 0, \\ x-1 > (3-x)^2 \end{cases}$$

tengsizliklar sistemalarining birlashmasiga teng kuchlidir.

Birinchi sistemani yechamiz:

$$\begin{cases} 3-x < 0, \\ x-1 \geq 0 \end{cases} \Leftrightarrow \begin{cases} x > 3, \\ x \geq 1 \end{cases} \Rightarrow [x > 3.$$

Ikkinchi sistemani yechamiz:

$$\begin{cases} 3-x \geq 0, \\ x-1 > (3-x)^2 \end{cases} \Rightarrow \begin{cases} x \leq 3, \\ (x-2)(x-5) < 0 \end{cases} \Rightarrow [2 < x \leq 3.$$

(65-rasm).

Berilgan tengsizlikning yechimi a) va b) tengsizliklar sistemalarining yechimlari birlashmasidan iborat bo'ladi (66-rasm).



66-rasm

Tengsizlik  $x$  ning  $(2; +\infty)$  oraliqdagi barcha qiymatlarida bajariladi. Bu oraliqdagi eng kichik butun son 3 dir.

J a v o b: 3.

7-mis o l.  $2x^2 - 3x + 7 < 7\sqrt{(2x-1)(x-1)}$  tengsizlikni yeching.

Yechilishi. Berilgan tengsizlik o'zgaruvchi  $x$  ning  $(-\infty; \frac{1}{2}]$  va  $[1; +\infty)$  oraliqlarga tegishli barcha qiymatlarida aniqlangan.

$$2x^2 - 3x + 7 < 7\sqrt{(2x-1)(x-1)} \Leftrightarrow 2x^2 - 3x + 7 < 7\sqrt{2x^2 - 3x + 1}.$$

Tengsizlikni  $t = \sqrt{2x^2 - 3x + 1}$  almashtirish kiritish yo'li bilan yechamiz. U holda

$$\begin{aligned} t^2 + 6 < 7t &\Leftrightarrow t^2 - 7t + 6 < 0 \Leftrightarrow (t-1)(t-6) < 0 \Rightarrow \\ &\Rightarrow 1 < t < 6 \Rightarrow \begin{cases} t > 1, \\ t < 6. \end{cases} \end{aligned}$$

Eski o'zgaruvchiga qaytib, tengsizlikning yechimini topamiz:

$$\begin{cases} \sqrt{2x^2 - 3x + 1} > 1, \\ \sqrt{2x^2 - 3x + 1} < 6 \end{cases} \Leftrightarrow \begin{cases} 2x^2 - 3x + 1 > 1, \\ 2x^2 - 3x + 1 < 36 \end{cases} \Leftrightarrow \begin{cases} 2x(x - 1,5) > 0, \\ 2(x + 3,5)(x - 5) < 0 \end{cases} \Rightarrow$$

$$\Rightarrow \begin{cases} -3,5 < x < 0, \\ 1,5 < x < 5. \end{cases}$$



67-расм

Tengsizlikning yechimlar to'plami 67-rasmda tasvirlangan.

J a v o b:  $x \in (-3,5; 0) \cup (1,5; 5)$ .

### Mustaqil ishlash uchun test topshiriqlari

- $2x^2 - 28x - 30 \leq 0$  tengsizlikni yeching.  
A)  $[-1; 15]$ ; B)  $(-1; 15)$ ; C)  $(-\infty; -1)$ ; D)  $[15; +\infty)$ ;  
E)  $(-\infty; 1] \cup [15; +\infty)$ .
- $3x^2 - 7x + 4 \leq 0$  tengsizlikni yeching.  
A)  $[1; \frac{4}{3}]$ ; B)  $(-\infty; 1] \cup [\frac{4}{3}; +\infty)$ ; C)  $(-\infty; -1) \cup (\frac{4}{3}; +\infty)$ ;  
D)  $(-\infty; 1] \cup (\frac{4}{3}; +\infty)$ ; E)  $(-\infty; 1) \cup (\frac{4}{3}; +\infty)$ .
- $4x^2 + 12x + 9 \geq 0$  tengsizlikning yechimlari to'plamini ko'rsating.  
A)  $(-\infty; -1,5]$ ; B)  $(-\infty; -1,5)$ ; C)  $[1,5; +\infty)$ ; D)  $(1,5; +\infty)$ ;  
E)  $(-\infty; +\infty)$ .
- $25x^2 + 30x + 9 < 0$  tengsizlikni yeching.  
A)  $(-\infty; \frac{3}{5})$ ; B)  $(-\infty; -\frac{3}{5})$ ; C)  $\emptyset$ ;  
D)  $(-\infty; -\frac{3}{5}) \cup (-\frac{3}{5}; +\infty)$ ; E)  $(-\frac{3}{5}; +\infty)$ .
- $8 - x^2 > 0$  tengsizlikning butun yechimlari nechta?  
A) 2; B) 3; C) 4; D) 5; E) 6.
- $3x^2 - 2x > 0$  tengsizlikning eng kichik butun musbat yechimini toping.  
A) 5; B) 4; C) 3; D) 2; E) 1.

7.  $x^2 + x - 2 \leq 0$  tengsizlikning butun yechimlari yig'indisini toping.

A) -3; B) -2; C) -1; D) 0; E) 4.

8.  $x^2 + 2x - 15 < 0$  tengsizlikning natural yechimlari ko'paytmasini toping.

A) 0; B) 1; C) 2; D) 4; E) 6.

9.  $2x^4 - 34x^2 + 32 \leq 0$  tengsizlikning butun yechimlari o'rta arifmetigining qiymatini toping.

A) 1; B) -1; C) 0; D)  $-\frac{1}{4}$ ; E)  $\frac{1}{4}$ .

10.  $(x^2 - x - 1)(x^2 - x - 7) \leq -5$  tengsizlikning eng katta butun va eng kichik butun yechimlari ayirmasini toping.

A) 2; B) 3; C) 4; D) 5; E) 6.

11.  $(x - 2)(x - 5)(x - 12) > 0$  tengsizlikni yeching.

A)  $(2; 5) \cup (12; +\infty)$ ; B)  $(5; 12) \cup (12; +\infty)$ ; C)  $(-\infty; +\infty)$ ;  
D)  $(2; 12)$ ; E)  $(-\infty; 2) \cup (12; +\infty)$ .

12.  $(x + 7)(x + 1)(x - 4) \leq 0$  tengsizlikning butun musbat yechimlari yig'indisini toping.

A) 9; B) 8; C) 7; D) 10; E) 12.

13. O'zgaruvchi  $x$  ning qanday qiymatlarida  $-x^2 - \frac{1}{3}x - \frac{1}{36}$  kvadrat uchhad manfiy qiymatlar qabul qiladi?

A)  $x \in (-\infty; +\infty)$ ; B)  $(-\infty; -\frac{1}{6}]$ ; C)  $(-\infty; -\frac{1}{6})$ ;

D)  $[-\frac{1}{6}; +\infty)$ ; E)  $(-\infty; -\frac{1}{6}) \cup (-\frac{1}{6}; +\infty)$ .

14. Tengsizliklar sistemasini yeching: 
$$\begin{cases} 4x^2 - 27x - 7 > 0, \\ x > 0. \end{cases}$$

A)  $(7; +\infty)$ ; B)  $(-\infty; 7]$ ; C)  $(-\infty; 7)$ ; D)  $[7; +\infty)$ ; E)  $[\frac{1}{4}; +\infty)$ .

15. 
$$\begin{cases} x - 4 > 0, \\ 3x^2 - 15x < 0 \end{cases}$$
 tengsizliklar sistemasining butun yechimlari

yig'indisini toping.

A) 9; B) 6; C) 3; D) 1; E) 0.

$$16. \begin{cases} x^2 + 4x - 5 > 0, \\ x^2 - 2x - 8 < 0 \end{cases} \text{ tengsizliklar sistemasining eng kichik butun}$$

yechimini toping.

A) 2;      B) -1;      C) 3;      D) -2;      E) -3.

$$17. \frac{6-x}{x-4} \leq 0 \text{ tengsizlikni yeching.}$$

A) (4; 6];      B) [4; 6];      C)  $(-\infty; 4) \cup [6; +\infty)$ ;

D)  $(-\infty; -4) \cup (6; +\infty)$ ;      E)  $(-\infty; -4) \cup [6; +\infty)$ .

18.  $\frac{4x-1}{x-1} = k+3$  tenglama  $k$  ning qanday qiymatlarida manfiy yechimga ega bo'ladi?

A)  $(-\infty; -2)$ ;      B)  $(-\infty; -2) \cup [1; +\infty)$ ;      C)  $(-2; 1)$ ;

D)  $(1; +\infty)$ ;      E)  $(-\infty; -2) \cup (1; +\infty)$ .

$$19. 0 < \frac{3x-1}{2x+5} < 1 \text{ qo'sh tengsizlikni yeching.}$$

A)  $(\frac{1}{3}; 6)$ ;      B)  $(-\frac{5}{2}; +\infty)$ ;      C)  $(\frac{1}{3}; +\infty)$ ;

D)  $(-\frac{5}{2}; 6)$ ;      E)  $(-\infty; -\frac{5}{2}) \cup (\frac{1}{3}; 6)$ .

$$20. \frac{-3x^2 + 4x - 5}{2x+3} > 0 \text{ tengsizlikni yeching.}$$

A)  $(-\infty; -1.5)$ ;      B)  $(-1.5; 2)$ ;      C)  $(-4; -1.5)$ ;

D)  $(-1.5; -1.2)$ ;      E)  $(-\infty; -2.5)$ .

$$21*. \frac{|x-3|}{x^2-5x+6} \geq 2 \text{ tengsizlikni yeching.}$$

A) yechimi yo'q;      B) [1.5; 2];      C) (2.5; 4);

D) [2.5; 4];      E) [-10; 10].

$$22. x^2 - 2|x| - 8 \geq 0 \text{ tengsizlikni yeching.}$$

A)  $(-\infty; -2]$ ;      B)  $[4; +\infty)$ ;      C)  $[-2; 2]$ ;

D)  $(-\infty; -4] \cup [4; +\infty)$ ;      E)  $[-4; 4]$ .

$$23. x^2 - 6|x| - 7 \leq 0 \text{ tengsizlik nechta butun yechimga ega?}$$

A) 15;      B) 14;      C) 8;      D) 7;      E) 2.

24.  $\frac{2x^2-15x-50}{3x^2+17x-6} > 0$  tengsizlikni yeching.

A)  $(-\infty; -6) \cup (-2,5; \frac{1}{3}) \cup (10; +\infty)$ ; B)  $(-6; 10)$ ;

C)  $(-2,5; 10)$ ; D)  $(-6; \frac{1}{3})$ ; E)  $(-2,5; \frac{1}{3}) \cup (10; +\infty)$ .

25.  $\frac{(x+5)^3(x+3)x^2}{(x+4)^2(x-2)^3} > 0$  tengsizlikning eng kichik butun musbat yechimini toping.

A) 1; B) 2; C) 3; D) 4; E) 5.

26\*.  $\left| \frac{2x-4}{x+1} \right| > 2$  tengsizlikni yeching.

A)  $(-\infty; +\infty)$ ; B)  $(-\infty; -1)$ ; C)  $(-\infty; 0,5)$ ;

D)  $(-\infty; -1) \cup (-1; 0,5)$ ; E)  $(-\infty; -1) \cup (-1; 0,5) \cup (0,5; +\infty)$ .

27\*.  $\frac{x^2+6x-7}{|x+4|} < 0$  tengsizlikni yeching.

A)  $(-7; 1)$ ; B)  $(-7; -4) \cup (-4; 1)$ ; C)  $(-4; 1)$ ;

D)  $(-7; -4)$ ; E)  $(-\infty; -7) \cup (-7; -4) \cup (-4; 1) \cup (-4; +\infty)$ .

28\*.  $\left| \frac{x^2-3x-1}{x^2+x+1} \right| < 3$  tengsizlikni yeching.

A)  $(-\infty; +\infty)$ ; B)  $(-2; -1)$ ; C)  $(-\infty; -2) \cup (-1; +\infty)$ ;

D)  $(-2; +\infty)$ ; E)  $(-\infty; -2) \cup (-2; -1) \cup (-1; +\infty)$ .

29.  $a$  ning qanday qiymatlarida  $|x| < \frac{a}{x}$  tengsizlik yechimga ega emas?

A)  $a < 0$ ; B)  $a > 0$ ; C)  $a \in R$ ; D)  $a = 0$ ;

E)  $(-\infty; 0) \cup (0; +\infty)$ .

30\*.  $a$  parametrining qanday qiymatlarida

$$\frac{2-ax-x^2}{1-x+x^2} \leq 3$$

tengsizlik o'zgaruvchi  $x$  ning barcha qiymatlarida bajariladi?

A)  $a \in [-1; 7]$ ; B)  $a \in [-4; 4]$ ; C)  $a \in (-1; 7)$ ; D)  $a \in [4; 7]$ ;

E)  $a \in (-\infty; -1] \cup (7; +\infty]$ .

31.  $\sqrt{x+4\sqrt{x+1}+5} + \sqrt{18+6\sqrt{9-x}-x} = 9$  tenglamaning ildizlari yig'indisini toping.

- A)  $\emptyset$ ;      B) 4;      C) 2;      D) 8;      E) 9.

32.  $\sqrt[3]{x^2} \sqrt[3]{x^2} \sqrt[3]{x^2} \dots = 49$  tenglamani yeching.

- A) 49;      B) 7;      C) 39;      D) 50;      E) 24.

33.  $\sqrt{x+1} + \sqrt{2x+3} = 1$  tenglamani yeching.

- A) -1;      B) 3;      C) -1,3;      D) 1;      E) -3.

34.  $\sqrt{x^2+77} - 2\sqrt[4]{x^2+77} - 3 = 0$  tenglamaning ildizlari ko'paytmasini toping.

- A) -3;      B) 3;      C) 4;      D) -4;      E) -6.

35.  $3\sqrt{2x} - 5\sqrt{8x} + 7\sqrt{18x} = 28$  tenglamani yeching.

- A) 1;      B) 2;      C) 3;      D) 4;      E) 6.

36.  $(16-x^2)\sqrt{3-x} = 0$  tenglamaning ildizlari yig'indisini toping.

- A) 7;      B) 3;      C) 0;      D) -2;      E) -1.

37.  $\sqrt{x+1} - \sqrt{x+7} + \sqrt{8+2\sqrt{x+7}+x} = 4$  tenglamaning nechta ildizi bor?

- A)  $\emptyset$ ;      B) 1;      C) 3;      D) 2;      E) 4.

38.  $\sqrt[3]{x^3+19} = x+1$  tenglama katta ildizining kichik ildiziga nisbatini toping.

- A)  $\frac{1}{2}$ ;      B)  $-\frac{2}{3}$ ;      C)  $\frac{2}{3}$ ;      D)  $-\frac{1}{2}$ ;      E)  $-\frac{3}{4}$ .

39.  $\sqrt{2-x} + \frac{4}{\sqrt{2-x+3}} = 2$  tenglama nechta ildizga ega?

- A) Ildizi yo'q;      B) 1;      C) 2;      D) 3;      E) 4.

40.  $\frac{x\sqrt[3]{x-1} - \sqrt[3]{x^2-1}}{\sqrt[3]{x^2-1} - \sqrt[3]{x+1}} = 4$  tenglamaning ildizlari yig'indisini toping.

- A) 7;      B) 8;      C) 9;      D) 10;      E) 11.

41.  $\sqrt[3]{16-x^3} = 4-x$  tenglamaning ildizini toping.

- A) 0; B) 1; C) 2; D) 4; E) -2.

42\*.  $\sqrt[3]{12-x} + \sqrt[3]{14+x} = 2$  tenglamaning ildizlari ko'paytmasini toping.

- A) -125; B) 205; C) 225; D) -205; E) -195.

43.  $\sqrt{\frac{3-x}{2+x}} + 3\sqrt{\frac{2+x}{3-x}} = 4$  tenglamaning ildizlari ko'paytmasini toping.

- A) 0,75; B) -0,75; C) 2,25; D) -1,5; E) 0,5.

44\*.  $a$  ning qanday qiymatida  $x + \sqrt{a + \sqrt{x}} = a$  tenglama ildizi faqat nolga teng bo'ladi?

- A) bunday qiymatlar yo'q; B)  $(-\infty; 0) \cup (0; 1)$ ; C)  $[1; +\infty)$ ; D)  $\{0\}$ ; E)  $[0; 1]$ .

45.  $\sqrt{x^2 - 2x + 1} + \sqrt{x^2 + 2x + 1} = 2$  tenglamani yeching.

- A)  $x < -1$ ; B)  $[-1; 1]$ ; C)  $x > 1$ ; D)  $(-1; 1)$ ; E)  $[-2; 0]$ .

46\*.  $\sqrt{x^2 + x + 4} + \sqrt{x^2 + x + 1} = \sqrt{2x^2 + 2x + 9}$  tenglamaning eng katta ildizi 10 dan qancha kam?

- A) 10; B) 9; C) 11; D) 8; E) 7.

47\*.  $\frac{a-2}{\sqrt{x+4}} = 1$  tenglama  $a$  ning qanday qiymatlarida yechimga ega?

- A)  $a \in (-\infty; +\infty)$ ; B)  $a \in (0; 2)$ ; C)  $a \in (2; +\infty)$ ; D)  $a \in [2; +\infty]$ ; E)  $a \in (-2; +\infty)$ .

48\*.  $\sqrt{x^2 + 1} - \frac{1}{\sqrt{x^2 - 5}} = x$  tenglama nechta ildizga ega?

- A) 2; B) 4; C) 3; D) 1; E) 0.

49.  $(x^2 - 1)\sqrt{x^2 - x - 2} \geq 0$  tengsizlikni yeching.

- A)  $(-1; 1)$  B)  $(-\infty; -1] \cup [2; +\infty)$  C)  $[-1; 2]$ ; D)  $[-1; 1) \cup [2; +\infty)$ ; E)  $[-1; +\infty)$ .



50.  $\sqrt{1 - \frac{x+2}{x^2}} < \frac{2}{3}$  tengsizlikning musbat butun ildizlari yig'indisini toping.

- A) 8;      B) 6;      C) 5;      D) 3;      E) 2.

51.  $\frac{\sqrt{2x^2+15x-17}}{10-x} \geq 0$  tengsizlik musbat butun yechimlarining o'rta arifmetik qiymatini toping.

- A) 12;      B) 5;      C) 13.5;      D) 24;      E) 10.

52.  $\frac{x^2-13x+40}{\sqrt{19x-x^2-78}} \leq 0$  tengsizlikning butun yechimlari yig'indisini toping.

- A) 81;      B) 76;      C) 15;      D) 21;      E) 50.

53\*.  $\sqrt{3x-10} > \sqrt{6-x}$  tengsizlikni yeching.

- A) (4; 6);      B) [4; 6];      C) (4; 6);      D)  $(3\frac{1}{3}; 6]$ ;      E)  $(3\frac{1}{3}; 6)$ .

54.  $(x-1)\sqrt{x^2-x-2} \geq 0$  tengsizlikni yeching.

- A)  $(-\infty; -1]$ ;      B)  $(-\infty; -1] \cup [1; +\infty)$ ;      C) [1; 2];      D) [2; +\infty);  
E) [1; +\infty).

55.  $2x^2 - 7(\sqrt{x})^2 \leq 4$  tengsizlik bajariluvchi kesma o'rtasining absissasini toping.

- A) 2;      B) 2.25;      C) 1.75;      D) 1;      E) 2,5.

56\*.  $\sqrt{x^2} < x+1$  tengsizlikni yeching.

- A)  $(0; +\infty)$ ;      B)  $(0; \frac{1}{2})$ ;      C)  $[\frac{1}{2}; +\infty)$ ;      D)  $(-\infty; +\infty)$ ;  
E)  $(-\frac{1}{2}; +\infty)$ .

57\*.  $2\sqrt{x-1} < x$  tengsizlikni yeching.

- A)  $x \in \emptyset$ ;      B)  $x \in [1; 2) \cup (2; +\infty)$ ;      C)  $x \in [1; +\infty)$ ;  
D)  $x \in [2; +\infty)$ ;      E)  $x \in (2; +\infty)$ .

58\*.  $\sqrt{2x-1} < x-2$  tengsizlikning eng kichik butun musbat yechimini ko'rsating.

A) 1;      B) 2;      C) 3;      D) 4;      E) 6.

59\*.  $\sqrt{(x-6)(1-x)} < 3+2x$  tengsizlikning natural yechimlari nechta?

A) 1;      B) 2;      C) 3;      D) 4;      E) 6.

60\*.  $x < \sqrt{2-x}$  tengsizlikni yeching.

A) (1; 2];    B)  $(-\infty; 1)$ ;    C) [0; 1);    D) (-2; 2];    E)  $(-\infty; 2]$ .

61.  $\sqrt{x^2+4x-5} > x-3$  tengsizlikni yeching.

A)  $(-\infty; -5] \cup [1; +\infty)$ ;    B) [1; 3];    C) [3; +\infty);

D) [1; 3)  $\cup$  (3; +\infty);    E)  $(-\infty; 3) \cup (3; +\infty)$ .

62\*.  $\sqrt{x^2+1} > x-1$  tengsizlikni yeching.

A) [1; +\infty);    B) (0; +\infty);    C)  $(-\infty; +\infty)$ ;    D)  $(-\infty; 0]$ ;

E) (1; +\infty).

63\*.  $\frac{\sqrt{2x-1}}{x-2} < 1$  tengsizlikni yeching.

A) (2; 5)  $\cup$  (5; +\infty);    B)  $[\frac{1}{2}; 2) \cup (5; +\infty)$ ;    C)  $[\frac{1}{2}; +\infty)$ ;

D)  $[\frac{1}{2}; 5) \cup (5; +\infty)$ ;    E) (2; +\infty).

64\*.  $1 - \frac{\sqrt{1-4x^2}}{x} < 3$  tengsizlikning butun yechimlari nechta?

A) yo'q;    B) 1;    C) 2;    D) 3;    E) 4.

65\*.  $3\sqrt{x} - \sqrt{x+3} > 1$  tengsizlikning eng kichik butun yechimini ko'rsating.

A) 1;      B) 2;      C) 3;      D) 4;      E) 5.

## HAQIQIY SONLAR TO'PLAMIDA ANIQLANGAN FUNKSIYA

### 1-§. *Funksiya tushunchasi*

Funksiya tushunchasi matematikaning eng muhim va eng umumiy tushunchalaridan biridir.

**1.1. O'zgarmas va o'zgaruvchi miqdorlar.** Kundalik turmushimizda har qadamda miqdor tushunchasiga kelamiz. *O'lchanishi mumkin bo'lgan va son yoki sonlar bilan ifodalanadigan qiymat miqdor deyiladi.* Masalan, uzunlik, yuz, hajm, og'irlik, harorat, tezlik, tezlanish, kuch va hokazolar. Turli jarayonlarni kuzatish bu jarayonlarda qatnashadigan ayrim miqdorlar o'zgarishini, ayrimlari esa o'zgarmay qolishini ko'rsatadi. Masalan, jismni biror balandlikdan erkin tushishida masofa, vaqt va tezlik o'zgaruvchi miqdorlar, tezlanish esa o'zgarmas miqdordir:

$$S = \frac{1}{2} g t^2,$$

bu munosabatda  $S$  – masofa,  $t$  – vaqt,  $g$  – erkin tushish tezlanishi.

Geometriyadan ma'lumki, kubning hajmi uning chiziqli o'lchami – kub qirrasini uzunligining kubiga teng, ya'ni

$$V = a^3 \text{ kub birlik,}$$

bunda  $V$  – kub hajmi,  $a$  – kub qirrasining uzunligi. Bu formula yordamida ixtiyoriy kub hajmini hisoblash mumkin.

Yana bir misol. Biror gaz o'zgarmas haroratda siqilsa, uning hajmi ( $V$ ) va bosimi ( $p$ ) o'zgaradi: hajmi kichrayadi, bosimi ortadi. Bu ikki miqdorning ko'paytmasi Boyle-Mariott qonuniga ko'ra o'zgarmasdan qolaveradi, ya'ni

$$V \cdot p = c,$$

bunda  $c$  – biror o'zgarmas miqdor.

Keltirilgan misollarda ikki miqdor o'zaro shunday bog'langan-ki, bulardan birining mumkin bo'lgan har bir qiymatiga ikkinchisining to'la aniq bir qiymati mos keladi.

Ta'rif. Ikki o'zgaruvchi miqdor orasidagi bog'lanish funksional bog'lanish deyiladi.

Ikki o'zgaruvchi miqdor taqqoslanayotganda ulardan birini *erkli o'zgaruvchi miqdor* deb, ikkinchisini *erksiz o'zgaruvchi miqdor* deb qaraladi. Masalan, doira yuzini aniqlovchi

$$S = \pi r^2$$

munosabatda doiraning radiusi  $r$  ni erkli o'zgaruvchi, doiraning yuzi  $S$  ni erksiz o'zgaruvchi miqdor deb qaralishi tabiiydir.

Ikki o'zgaruvchi miqdordan qaysi birini erkli o'zgaruvchi, qaysi birini erksiz o'zgaruvchi deb qarash masalaning qo'yilishiga qarab hal qilinadi. Masalan, gaz qisilganda uning bosimi qanday o'zgarishini bilmoqchi bo'lsak, hajmni erkli o'zgaruvchi, bosimni esa erksiz o'zgaruvchi miqdor deb qarash kerak:

$$p = \frac{c}{V}$$

**1.2. Funksiyaning umumiy ta'rif.** O'zgaruvchi miqdor  $x$  ning biror qiymatlar to'plamini qaraylik, ya'ni  $Ox$  son o'qidagi biror  $D$  nuqtalar to'plamini olaylik.

Ta'rif. Agar  $x$  ning bu to'plamdan olingan har bir qiymatiga tayin qoida asosida boshqa o'zgaruvchi  $y$  miqdorning to'la aniq qiymati mos keltirilsa, u holda  $y$  miqdor  $x$  miqdorning funksiyasi deyiladi.  $x$  miqdor  $y$  funksiyaning *argumenti*,  $D$  to'plam esa *y funksiyaning aniqlanish sohasi* deyiladi.

Biz argument  $x$  ning funksiyaning aniqlanish sohasi  $D$  to'plamdan ixtiyoriysini tanlashga haqlimiz. Shu sababli  $x$  miqdor *erkli o'zgaruvchi* deyiladi.  $y$  funksiyaning qiymati esa ixtiyoriy bo'lmay, balki tanlangan  $x$  ga ma'lum qoida asosida qat'iy mos qo'yiladi. Shu sababli funksiyani *erksiz o'zgaruvchi* ham deyiladi.

$y$  o'zgaruvchi  $x$  argumentning funksiyasi ekanligini ifodalash uchun odatda ushbu belgilashlardan foydalaniladi:  $y = f(x)$ ;  $y = g(x)$ ;  $y = \varphi(x)$  va hokazo (bu belgilashlar mos ravishda quyidagicha o'qiladi: igrek barobar ef iks; igrek barobar je iks; igrek barobar fi iks va hokazo). Funksiyani belgilashda ishlatiladigan  $f$ ,  $g$ ,  $\varphi$  harflari ikki o'zgaruvchi miqdor  $x$  va  $y$  orasidagi bog'lanish qoidalarini ifodalaydi. Masalan,

$$y = x^2 + 1$$

bog'lanishda  $f(x) = x^2 + 1$  yozuv tanlangan  $x$  ning qiymati avval kvadratga ko'tarilishini, so'ngra hosil bo'lgan qiymatga 1 qo'shib,  $y$  funksiyaning qiymati hosil qilinishini anglatadi.

### 1.3. Funksiyaning aniqlanish sohasi va qiymatlar to'plami.

Ta'rif. *Erkli o'zgaruvchi  $x$  ning qabul qilishi mumkin bo'lgan qiymatlar to'plami  $y$  funksiyaning aniqlanish sohasi deyiladi va  $D(y)$  kabi belgilanadi. Erksiz o'zgaruvchi  $y$  ning qabul qiladigan qiymatlar to'plami funksiyaning qiymatlar to'plami (o'zgarish sohasi) deyiladi va  $E(y)$  ko'rinishda belgilanadi.*

Agar funksiya biror formula bilan berilgan bo'lsa va uning aniqlanish sohasi ko'rsatilmasa, u holda erkli o'zgaruvchi  $x$  ning bu formula ma'noga ega bo'ladigan barcha qiymatlar to'plami funksiyaning aniqlanish sohasi ekanligi nazarda tutilgan bo'ladi. Masalan,

$$y = \frac{2}{x-2}$$

funksiyaning aniqlanish sohasi 2 dan boshqa barcha haqiqiy sonlar to'plamidan iborat.

$$y = \sqrt{x-2}$$

funksiyaning aniqlanish sohasi esa  $x \geq 2$  tengsizlikni qanoatlantiruvchi barcha haqiqiy sonlar to'plamidan iborat.

$x = a$  da  $f(x)$  funksiya qabul qiladigan qiymat  $f(a)$  bilan belgilanadi. Masalan,  $f(x) = x^2 + 1$  bo'lsa, bu holda

$$f(1) = 1^2 + 1 = 2, \quad f(a+1) = (a+1)^2 + 1 = a^2 + 2a + 2,$$

$$f(1,5) = 1,5^2 + 1 = 2,25 + 1 = 3,25, \quad f(\sqrt{t}) = (\sqrt{t})^2 + 1 = t + 1$$

$$f(2) = 2^2 + 1 = 4 + 1 = 5,$$

va hokazo.

Funksiyaning aniqlanish sohasi va qiymatlar to'plamini topishga doir misollar ko'ramiz.

1-misol.  $y = \frac{x-1}{x^2-4}$  funksiyaning aniqlanish sohasini toping.

Yechilishi. Bu funksiya  $x$  argumentning kasrning maxrajini nolga aylantiradigan qiymatlaridan boshqa barcha qiymatlarida aniqlangan.  $x^2 - 4 = 0$  tenglamani yechib,  $x_1 = -2$ ;  $x_2 = 2$  ekanini topamiz. Shuning uchun berilgan funksiyaning aniqlanish sohasi  $-2$  va  $2$  dan boshqa barcha haqiqiy sonlar to'plamidan iborat.

Javob:  $x \in (-\infty; -2) \cup (-2; 2) \cup (2; +\infty)$ .

2-misol.  $y = \sqrt{\frac{x-1}{x^2+2x-3}}$  funksiyaning aniqlanish sohasini toping.

Yechilishi. Kvadrat ildizlar faqat manfiy bo'lmagan sonlar uchun aniqlangan. Shuning uchun berilgan funksiyaning aniqlanish sohasi  $x$  ning

$$\frac{x-1}{x^2+2x-3} \geq 0$$

tengsizlikni qanoatlantiruvchi barcha qiymatlari to'plamidan iborat bo'ladi. Bu tengsizlikni yechamiz:

$$\begin{aligned} \frac{x-1}{x^2+2x-3} \geq 0 &\Leftrightarrow \frac{x-1}{(x-1)(x+3)} \geq 0 \left[ \begin{array}{l} x \neq 1 \\ x \neq -3 \end{array} \right] \Rightarrow \frac{1}{x+3} \geq 0 \Rightarrow \\ &\Rightarrow x+3 > 0 \Rightarrow [x > -3. \end{aligned}$$

Javob:  $x \in (-3; 1) \cup (1; +\infty)$ .

3-misol.  $y = x^2 - 4x + 7$  funksiyaning qiymatlar to'plamini toping.

Yechilishi. 1-usul. Berilgan funksiya kvadrat uchhad bo'lib, uning grafiqi parabola ekanligini bilamiz. Bu parabola tarmoqlari yuqoriga yo'nalgan, uning uchini abssissasi va ordinatasi

$$x_1 = 2, \quad y_1 = 3.$$

Demak, berilgan funksiyaning o'zgarish sohasi 3 va undan katta sonlar to'plamidan iborat.

2-usul. Kvadrat uchhadda to'la kvadratni ajratamiz:

$$y = x^2 - 4x + 4 + 3 = (x-2)^2 + 3.$$

Bunda  $(x-2)^2$  ifoda manfiy bo'lmagan qiymatlar qabul qiladi va uning eng kichik qiymati nol ekanligi ravshan. Demak, berilgan funksiyaning qiymatlari 3 va undan katta bo'lgan barcha sonlardan iborat.

Javob:  $[3; +\infty)$ .

**Ayrim funksiyalarning qiymatlar to'plamini topishda  $y = f(x)$  funksiyaning o'zgarish sohasi**

$$f(x) = a$$

tenglama yechimga ega bo'ladigan  $a$  ning  $a \in R$  bo'lgan barcha qiymatlar to'plamlari birlashmasidan iborat ekanligidan foydalanish qulaydir.

4-misol.  $y = \frac{2x}{x^2+1}$  funksiyaning qiymatlar to'plamini toping.

Yechilishi.  $\frac{2x}{x^2+1} = a$  tenglama  $a$  ning qanday qiymatlarida yechimga ega bo'lishini tekshiramiz:

$$\frac{2x}{x^2+1} = a \Leftrightarrow 2x = ax^2 + a \Leftrightarrow ax^2 - 2x + a = 0.$$

Bu tenglama  $a = 0$  da chiziqli bo'lib, uning ildizi  $x = 0$ .  $a \neq 0$  bo'lsa, tenglama kvadrat tenglama bo'lib,  $D \geq 0$ ; yechimga ega:

$$D = 4 - 4a^2 \geq 0 \Rightarrow a^2 - 1 \leq 0 \Rightarrow -1 \leq a \leq 1.$$

Javob:  $[-1; 1]$ .

5-misol.  $y = \sqrt{2x - x^2}$  funksiyaning qiymatlar to'plamini toping.

Yechilishi.  $\sqrt{2x - x^2} = a$  irratsional tenglama  $a$  ning qanday qiymatlarida yechimga ega bo'lishini ko'rib chiqamiz. Bu tenglama  $a \geq 0$  bo'lganda ma'noga ega. Tenglamaning har ikki qismini kvadratga oshirib,

$$x^2 - 2x + a^2 = 0$$

tenglamani hosil qilamiz. Uning diskriminanti  $4 - 4a^2$  nomanfiy bo'lishi shartidan

$$-1 \leq a \leq 1$$

ekanligi kelib chiqadi.  $a \geq 0$  ekanligini hisobga olsak,  $0 \leq a \leq 1$ .

Javob:  $[0; 1]$ .

## 2-§. Funksiyaning berilish usullari

Funksiyaning berilishi deganda argumentning qiymatlari bo'yicha funksiyaning mos qiymatlarini qanday topishni ko'rsatish tushuniladi.

**2.1. Funksiyaning analitik usulda berilishi.** Eng ko'p tarqalgan usul - bu funksiyani  $y = f(x)$  formula yordamida berishdir, bu yerda  $f(x)$  - birorta  $x$  o'zgaruvchili ifoda. Bunday holda funksiya *analitik* usulda berilgan deyiladi. Masalan,

$$y = x^2 + 5x - 1, \quad y = \sqrt{x-1}, \quad y = \frac{x^2 - 2x}{x^3 + 3}, \quad y = |x - 3| + 3.$$

1-misol.  $y = f(x)$  funksiya

$$f(x) = \frac{x^2 + x + 1}{x^4 + 3}$$

formula bilan berilgan. Quyidagilarni toping:

a)  $f(-x)$ ;      b)  $f(kx)$ ;      d)  $f(x+a)$ ;      e)  $f(|x|)$ .

Yechilishi. a)  $f(-x)$  ni topish uchun  $f(x)$  da  $x$  o'rniga  $(-x)$  ni qo'yish kerak:

$$f(-x) = \frac{(-x)^2 + (-x) + 1}{(-x)^4 + 3} = \frac{x^2 - x + 1}{x^4 + 3}.$$

Shunga o'xshash:

$$b) f(kx) = \frac{(kx)^2 + (kx) + 1}{(kx)^4 + 3} = \frac{k^2x^2 + kx + 1}{k^4x^4 + 3};$$

$$d) f(x+a) = \frac{(x+a)^2 + (x+a) + 1}{(x+a)^4 + 3};$$

$$e) f(|x|) = \frac{|x|^2 + |x| + 1}{|x|^4 + 3} = \frac{x^2 + |x| + 1}{x^4 + 3}.$$

Funksiya turli oraliqlarda turli ifodalar bilan berilishi mumkin.  
Masalan.

$$f(x) = \begin{cases} 2x + 3, & \text{agar } -1 \leq x \leq 0 \text{ bo'lsa,} \\ x + 2, & \text{agar } 0 < x \leq 1 \text{ bo'lsa.} \end{cases}$$

Bu funksiya  $[-1; 1]$  kesmada aniqlangan. Funksiyaning qiymatlarini hisoblash uchun argumentning berilgan tayin qiymati uchun qaysi formuladan foydalanishni aniq bilib olish kerak. Masalan, agar  $f(0.5)$  ni hisoblash kerak bo'lsa,  $f(x) = x + 2$  tenglikdan foydalanamiz va  $f(0.5) = 2.5$  ni hosil qilamiz. Agar  $f(-0.5)$  ni hisoblash zarur bo'lsa,  $f(x) = 2x + 3$  tenglikdan foydalanib,  $f(-0.5) = 2$  ni topamiz.

Bunday funksiyalar *bo'laklab berilgan funksiyalar* deyiladi. *Dirixle funksiyasi* deb ataluvchi ushbu

$$D(x) = \begin{cases} 1, & \text{agar } x \text{ ratsional bo'lsa,} \\ 0, & \text{agar } x \text{ ratsional bo'lsa.} \end{cases}$$

funksiya ham bo'laklab berilgan funksiyaga misol bo'la oladi.

**2.2. Funksiyaning jadval usulda berilishi.** Amalda ko'pgina hollarda funksiyaning **jadval usulda** berilishidan foydalaniladi. Bunda jadval keltirilib, unda argumentning keltirilgan qiymatlari uchun funksiyaning qiymatlari ko'rsatiladi. Funksiyaning jadval usulida berilishiga kvadratlar jadvali, kublar jadvali, kvadrat ildizlar jadvali misol bo'la oladi. Ko'pgina hollarda funksiyaning jadval usulda berilishi qulay bo'lib chiqadi. U argumentning jadvalda berilgan qiymatlari uchun funksiyaning qiymatlarini hech qanday hisoblashlarsiz topish imkonini beradi. Amalda ko'pincha bir kattalikning boshqasiga bog'liqligini tajriba yo'li bilan topiladi. Masalan, ushbu jadvalda misning turli  $t$  temperaturalardagi (gradus hisobida)  $p$  solishtirma qarshiligining ( $\Omega \cdot \text{sm}$  hisobida) tajribada olingan qiymatlari keltirilgan:



$t$	10	30	50	70	90	100
$p$	$1,8 \cdot 10^{-6}$	$1,9 \cdot 10^{-6}$	$2,0 \cdot 10^{-6}$	$2,2 \cdot 10^{-6}$	$2,3 \cdot 10^{-6}$	$2,4 \cdot 10^{-6}$

**2.3. Funksiyaning grafik usulda berilishi.** Bu usul funktsiyani analitik usulda berish qiyin bo'lgan hollarda qulaydir. Ko'pgina jarayonlarni o'rganishda turli asboblardan foydalaniladi. Bu asboblardan yordamida shunday egri chiziqlar hosil qilinadiki, bu egri chiziqlarga qarab bir o'zgaruvchi miqdorning ikkinchi o'zgaruvchi miqdorning o'zgarishiga bog'liq ravishda o'zgarishi xususiyati haqida tasavvurga ega bo'lishimiz mumkin. Masalan, tibbiyotda elektrokardiograflar keng ishlatiladi. Bu asboblardan yordamida elektrokardiogrammalarni – yurak mushaklarida hosil bo'ladigan elektr impulslarining o'zgarishini tasvirlovchi egri chiziqlar hosil qilinadi. Bunday egri chiziqlar yurakning ishlashi haqida to'g'ri xulosa chiqarishga yordam beradi.

Funksiyaning grafik usulda berilishidan matematikada ko'pincha funktsiyaning ba'zi xossalari ayoniy ko'rsatishda foydalaniladi. Funktsiya

$$y = f(x)$$

formula yordamida analitik berilgan bo'lsa, u holda koordinatalar tekisligida absissasi funktsiyaning aniqlanish sohasiga tegishli, ordinatasi funktsiyaning mos qiymatiga teng bo'lgan  $(x; f(x))$  nuqtalar to'plami *funktsiyaning grafigi* deyiladi. Masalan,

$$y = x$$

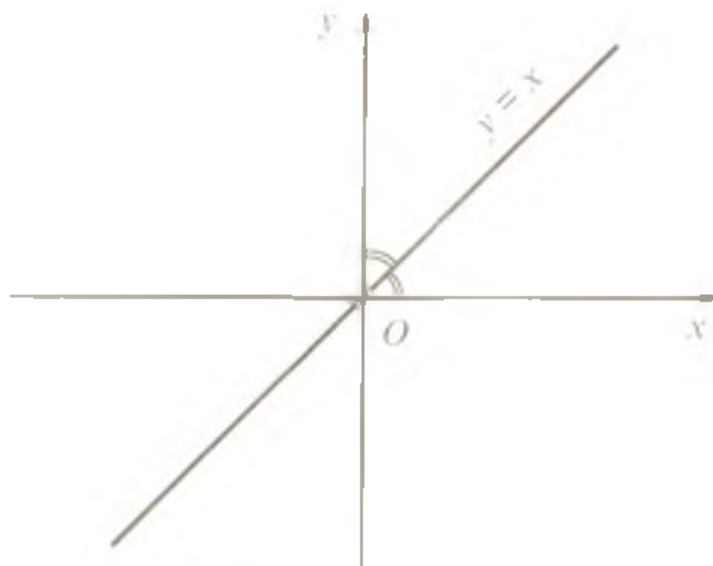

68-rasm

funktsiyaning grafigi  $(x; x)$  ko'rinishdagi nuqtalar, ya'ni bir xil koordinatalarga ega nuqtalar to'plamidan iborat bo'lib, bu to'plam I va III koordinatalar burchaklarining bissektrisasidir (68-rasm).

Amalda funktsiya grafigini yasash uchun argumentning ba'zi qiymatlariga

mos funksiyaning qiymatlari jadvali tuziladi, koordinatalar tekisligida tegishli nuqtalar belgilanadi va hosil bo'lgan nuqtalar chiziq bilan tutashtiriladi. Bunda funksiya grafigi silliq chiziq, topilgan nuqtalar esa funksiya o'zgarishini yetarlicha aniqlikda aks ettiradi, deb faraz qilinadi.

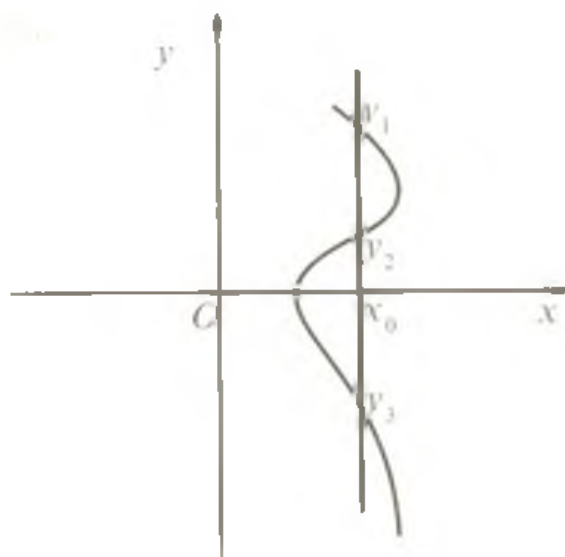

69-rasm

**Eslatma.** Koordinatalar tekisligidagi har qanday nuqtalar to'plami ham qandaydir funksiya grafigi bo'lavermaydi. Masalan, 69-rasmda tasvirlangan egri chiziqda  $x = x_0$  qiymatga  $y$  ning uchta  $y_1, y_2$  va  $y_3$  qiymatlari mos keladi va demak, bunday moslik funksiya bo'la olmaydi.

Koordinatalar tekisligining nuqtalar to'plami biror funksiyaning grafigi bo'lishi uchun  $Oy$  o'qiga parallel bo'lgan ixtiyoriy to'g'ri chiziq bu funksiya grafigi bilan faqat bitta nuqtada kesishishi zarur va yetarlidir.

### 3-§. Funksiyalarning umumiy xossalari

**3.1. Juft va toq funksiyalar.** Agar: 1) funksiyaning aniqlanish sohasi nolga nisbatan simmetrik bo'lsa, ya'ni funksiyaning aniqlanish sohasiga tegishli har qanday  $x$  uchun  $-x$  ham shu aniqlanish sohasiga tegishli bo'lsa; 2) funksiyaning aniqlanish sohasiga tegishli har qanday  $x$  uchun

$$f(-x) = f(x)$$

tenglik bajarilsa,  $f(x)$  funksiya juft deyiladi.

Juft funksiyaning grafigi  $Oy$  o'qiga nisbatan simmetrik bo'ladi.

Agar: 1) funksiyaning aniqlanish sohasi nolga nisbatan simmetrik bo'lsa; 2) funksiyaning aniqlanish sohasiga tegishli har qanday  $x$  uchun

$$f(-x) = -f(x)$$

tenglik bajarilsa,  $f(x)$  funksiya toq deyiladi.

Toq funksiyaning grafigi koordinatalar boshiga nisbatan simmetrik bo'ladi.

O'zining aniqlanish sohasiga tegishli har qanday  $x$  uchun

$$f(-x) = f(x),$$

$$f(-x) = -f(x)$$

tengliklardan hech birini qanoatlantirmaydigan funksiya *juft ham emas, toq ham emas* deyiladi.

Quyidagi tasdiqlar funksiyalarning juft-toqligini tekshirishni osonlashtiradi:

1) *ikki juft funksiya yig'indisi juft funksiya, ikki toq funksiya yig'indisi toq funksiya bo'ladi;*

2) *ikki juft funksiya ko'paytmasi ham, ikki toq funksiya ko'paytmasi ham juft funksiyalar bo'ladi;*

3) *juft va toq funksiyalar ko'paytmasi toq funksiyalar bo'ladi.*

$y = b$  (bu yerda  $b$  – biror son) formula bilan berilgan funksiya *o'zgarmas funksiya* deyiladi. Uning grafiqi absissalar o'qiga parallel va ordinatalar o'qidagi  $(0; b)$  nuqta orqali o'tuvchi to'g'ri chiziqdan iborat. O'zgarmas funksiya juft.

**3.2. Funksiyalarning o'sishi va kamayishi. Funksiyaning monotonligi.** Berilgan  $X$  sonli oraliqda argument  $x$  ning shu oraliqqa tegishli katta qiymatiga  $f(x)$  funksiyaning katta qiymati mos kelsa, ya'ni  $x_1 \in X$  va  $x_2 \in X$  lar uchun  $x_2 > x_1$  bo'lganda

$$f(x_2) > f(x_1)$$

tengsizlik bajarilsa,  $f(x)$  funksiya *shu oraliqda o'suvchi* deyiladi.

Berilgan  $X$  sonli oraliqda argument  $x$  ning shu oraliqqa tegishli katta qiymatiga  $f(x)$  funksiyaning kichik qiymati mos kelsa, ya'ni  $x_1 \in X$  va  $x_2 \in X$  lar uchun  $x_2 > x_1$  bo'lganda

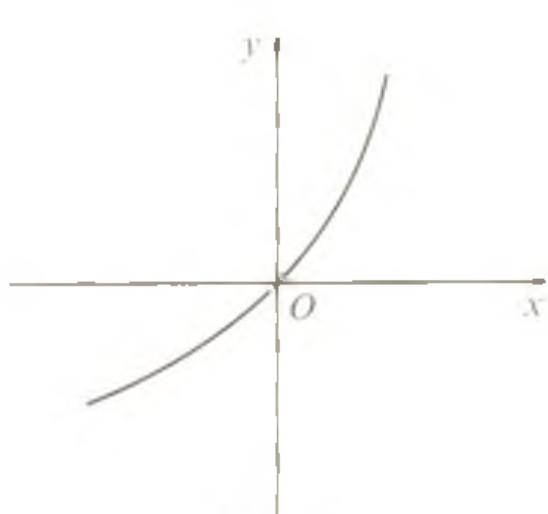

70-rasm

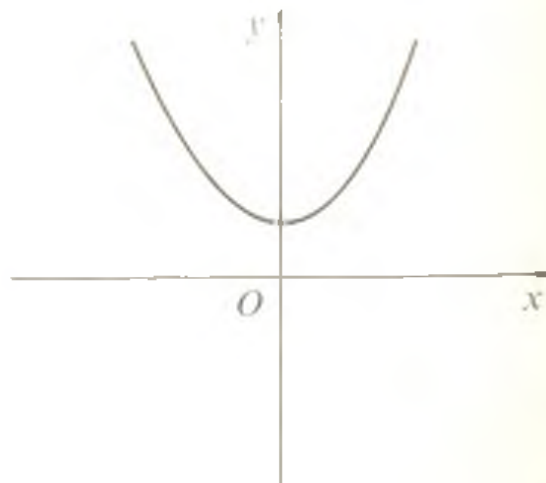

71-rasm

$$f(x_2) < f(x_1)$$

tengsizlik bajarilsa,  $f(x)$  funksiya shu oraliqda kamayuvchi deyiladi.

Ta'rif. Berilgan sonli oraliqda faqat o'suvchi yoki faqat kamayuvchi funksiya shu oraliqda monoton deyiladi.

Funksiyaning grafigi bo'yicha uni monotonligini aniqlash mumkin. Grafigi 70-rasmda tasvirlangan funksiya argument  $x$  ning har qanday qiymatida o'suvchidir. Grafigi 71-rasmda tasvirlangan funksiya esa  $(-\infty; 0]$  oraliqda kamayadi,  $[0; +\infty)$  oraliqda o'sadi.

**3.3. Funksiyaning nollari.** Argument  $x$  ning funksiya qiymatini nolga tenglashtiradigan,  $f(x) = 0$ , qiymatlari *funksiyaning nollari* deyiladi.

Masalan,  $y = x^2 + 7x - 8$  funksiyaning nollari ikkita:  $x_1 = -8, x_2 = 1$ . Haqiqatan,

$$y(-8) = 64 - 56 - 8 = 0, \quad y(1) = 1 + 7 - 8 = 0.$$

### 3.4. Davriy funksiyalar.

Ta'rif. Agar shunday  $T \neq 0$  son mavjud bo'lib, argument  $x$  ning  $y = f(x)$  funksiyaning aniqlanish sohasidan olingan barcha qiymatlarida  $x - T$  va  $x + T$  sonlar ham shu aniqlanish sohasiga tegishli bo'lsa va

$$f(x) = f(x \pm T)$$

tenglik bajarilsa,  $f(x)$  funksiya davriy funksiya deyiladi.  $T$  son funksiyaning davri deyiladi.

Agar  $T$  son  $f(x)$  funksiyaning davri bo'lsa, u holda  $kT$  ( $k \in \mathbb{Z}, k \neq 0$ ) ham shu funksiyaning davri bo'ladi. Demak, har qanday davriy funksiya cheksiz ko'p davrga ega.  $y = f(x)$  funksiyaning davri deganda odatda eng kichik musbat davr nazarda tutiladi. Ammo shuni nazarda tutish kerakki, davriy funksiyaning eng kichik musbat davri bo'lmasligi ham mumkin. Masalan,  $f(x) = 3$  funksiya uchun har qanday haqiqiy son davr bo'la oladi. Ammo musbat haqiqiy sonlar orasida eng kichigi mavjud emas.

Funksiyaning umumiy xossalarini aniqlashga doir bir necha misollar qaraymiz.

1-misol. 1)  $y = x + \frac{1}{x}$ ; 2)  $y = (x-3)^2 + (x+3)^2$ ; 3)  $y = x^2 - x + 3$  funksiyalarning juft-toqligini tekshiring.

Yechilishi: 1)  $y = x + \frac{1}{x}$  funksiya sonlar o'qining  $x = 0$  nuqtadan tashqari barcha nuqtalarida aniqlangan.  $y(-x)$  ni topamiz:

$$y(-x) = (-x) + \frac{1}{(-x)} = -x - \frac{1}{x} = -\left(x + \frac{1}{x}\right).$$

Demak,  $f(-x) = -f(x)$  tenglik bajarilyapti.  $y = x + \frac{1}{x}$  funksiya – toq.

2)  $y = (x - 3)^2 + (x + 3)^2$  funksiya sonlar o'qining barcha nuqtalarida aniqlangan. Funksiya argumenti ishorasini almashtiramiz:

$$\begin{aligned} y(-x) &= (-x - 3)^2 + (-x + 3)^2 = (-(x + 3))^2 + (-(x - 3))^2 = \\ &= (-1)^2(x + 3)^2 + (-1)^2(x - 3)^2 = (x - 3)^2 + (x + 3)^2. \end{aligned}$$

Bu yerda  $f(-x) = f(x)$  tenglik bajarilyapti, demak, berilgan funksiya juft.

3)  $y = x^2 - x + 3$  funksiya sonlar o'qining barcha nuqtalarida aniqlangan. Argumenti ishorasini almashtiramiz:

$$y(-x) = (-x)^2 - (-x) + 3 = x^2 + x + 3.$$

Bu yerda  $f(-x) = f(x)$  tenglik ham,  $f(-x) = -f(x)$  tenglik ham o'rinli emas. Demak, berilgan funksiya juft ham emas, toq ham emas.

2-misol.  $f(x) = \frac{x-5(x+6)}{2x-1} - \frac{x+5(x-6)}{2x+1}$  funksiyaning juft yoki toqligini aniqlang.

Yechilishi. Funksiyaning aniqlanish sohasi yo 0.5 dan tashqari barcha haqiqiy sonlar to'plamidan iborat, bu to'plam nolga nisbatan simmetrik. Funksiya argumenti ishorasini almashtiramiz:

$$\begin{aligned} f(-x) &= \frac{-x-5(-x+6)}{2(-x)-1} - \frac{-x+5(-x-6)}{2(-x)+1} = \frac{-x+5(x-6)}{-2(x+1)} - \frac{-x-5(x+6)}{-2(x-1)} = \\ &= \frac{x+5(x-6)}{2x+1} - \frac{x-5(x+6)}{2x-1} = -f(x). \end{aligned}$$

Demak, berilgan funksiya ta'rifga ko'ra toq funksiya ekan.

3-misol.  $y = kx + b$  funksiya  $k$  ning qanday qiymatlarida kamayishini aniqlang.

Yechilishi. Berilgan chiziqli funksiya son o'qining barcha nuqtalarida aniqlangan.  $x_1$  va  $x_2$  argumentning

$$x_2 > x_1$$

tengsizlikni qanoatlantiruvchi ixtiyoriy qiymatlari bo'lsin. Funksiyaning ularga mos keladigan qiymatlarini  $y_1$  va  $y_2$  bilan belgilaymiz:

$$y_1 = kx_1 + b; \quad y_2 = kx_2 + b.$$

$y_2 - y_1$  ayirmani qaraymiz:

$$y_2 - y_1 = kx_1 + b - (kx_2 + b) = kx_1 - kx_2 = k(x_2 - x_1).$$

Bunda  $(x_2 - x_1)$  ko'paytuvchi  $x_2 > x_1$  bo'lganligi uchun musbat. Shu sababli

$$k(x_2 - x_1)$$

ko'paytma ishorasi  $k$  koeffitsiyent ishorasi bilan aniqlanadi.  $k > 0$  bo'lsa.

$$k(x_2 - x_1) > 0 \text{ yoki } y_2 > y_1.$$

$y = kx + b$  funksiya o'suvchi.  $k < 0$  bo'lsa,

$$k(x_2 - x_1) < 0 \text{ yoki } y_2 < y_1.$$

$y = kx + b$  funksiya kamayuvchi.

Javob:  $y = kx + b$  funksiya  $k < 0$  bo'lsa, kamayuvchi bo'ladi.

4-misol.  $y = 2^{-x}$  funksiya  $(2; +\infty)$  oraliqda o'sishi yoki kamayishini aniqlang.

Yechilishi. Masala shartidan ko'rsatilgan oraliqda argumentning

$$x_2 > x_1$$

tengsizlikni qanoatlantiruvchi ixtiyoriy qiymatlarini tanlaymiz.  $x_1 = 3$ ,  $x_2 = 4$  bo'lsin. Funksiyaning shu qiymatlarga mos qiymatlarini hisoblaymiz:

$$y(x_1) = 2^{-3} = \frac{1}{8}, \quad y(x_2) = 2^{-4} = \frac{1}{16}.$$

Demak,  $y(x_2) < y(x_1)$  bo'lganligidan berilgan funksiya  $(2; +\infty)$  oraliqda o'suvchi, degan xulosaga kelamiz.

5-misol.  $y = 2 + \sqrt{3 - 5x}$  funksiya  $(-\infty; 0,6]$  oraliqda o'sishi yoki kamayishini aniqlang.

Yechilishi. Masala shartida berilgan oraliq funksiyaning aniqlanish sohasidan iborat. Argumentning funksiyaning aniqlanish sohasiga tegishli

$$x_2 > x_1$$

shartni qanoatlantiruvchi qiymatlarini tanlaymiz:

$$x_1 = -1,2; \quad x_2 = -0,2.$$

Funksiyaning shu qiymatlarga mos qiymatlarini hisoblaymiz:

$$y(x_1) = 2 + \sqrt{3 - 5 \cdot (-1,2)} = 2 + \sqrt{9} = 2 + 3 = 5;$$

$$y(x_2) = 2 + \sqrt{3 - 5 \cdot (-0,2)} = 2 + \sqrt{4} = 2 + 2 = 4.$$

Shunday qilib,

$$x_2 > x_1 \text{ da } y(x_2) < y(x_1)$$

bo'lganligi sababli berilgan funksiya o'zining aniqlanish sohasida kamayuvchi ekan.

6-misol.  $y = 2x^2$  funksiyaning  $-3 \leq x \leq 5$  kesmada juft-toqligini tekshiring.

Yechilishi. O'quvchilar juft darajali bunday ko'rinishdagi funksiyalarni, ko'rsatilgan oraliqqa e'tibor bermay, «bu funksiya juft funksiya» deb javob berishga odatlanib qolishgan. Lekin, ko'rsatilgan oraliqda  $y = 2x^2$  funksiya juft ham emas, toq ham emas, chunki  $[-3; 5]$  kesma koordinatalar boshiga nisbatan simmetrik emas.

Javob:  $y = 2x^2$  funksiya  $-3 \leq x \leq 5$  kesmada juft ham emas, toq ham emas.

#### 4-§. $y = [x]$ va $y = \{x\}$ funksiyalar

$x$  – haqiqiy son bo'lsin. Uning *butun qismi* deb  $x$  dan katta bo'lmagan eng katta butun songa aytiladi,  $x$  sonning butun qismi  $[x]$  kabi belgilanadi.  $x$  sonning *kasr qismi* deb, son bilan uning butun qismi ayirmasiga, ya'ni  $x - [x]$  ga aytiladi. Sonning kasr qismi  $\{x\}$  kabi belgilanadi. Demak,

$$\{x\} = x - [x].$$

Masalan.  $[2,35] = 2, \{2,35\} = 2,35 - 2 = 0,35;$

$$[10] = 10, \{10\} = 0;$$

$$[-0,85] = -1, \{-0,85\} = -0,85 - (-1) = 0,15.$$

$y = [x]$  funksiya grafigini yasaymiz.

Agar  $0 \leq x < 1$  bo'lsa,  $y = [x] = 0$ ;

agar  $1 \leq x < 2$  bo'lsa,  $y = [x] = 1$ ;

agar  $-1 \leq x < 0$  bo'lsa,  $y = [x] = -1$  va hokazo.

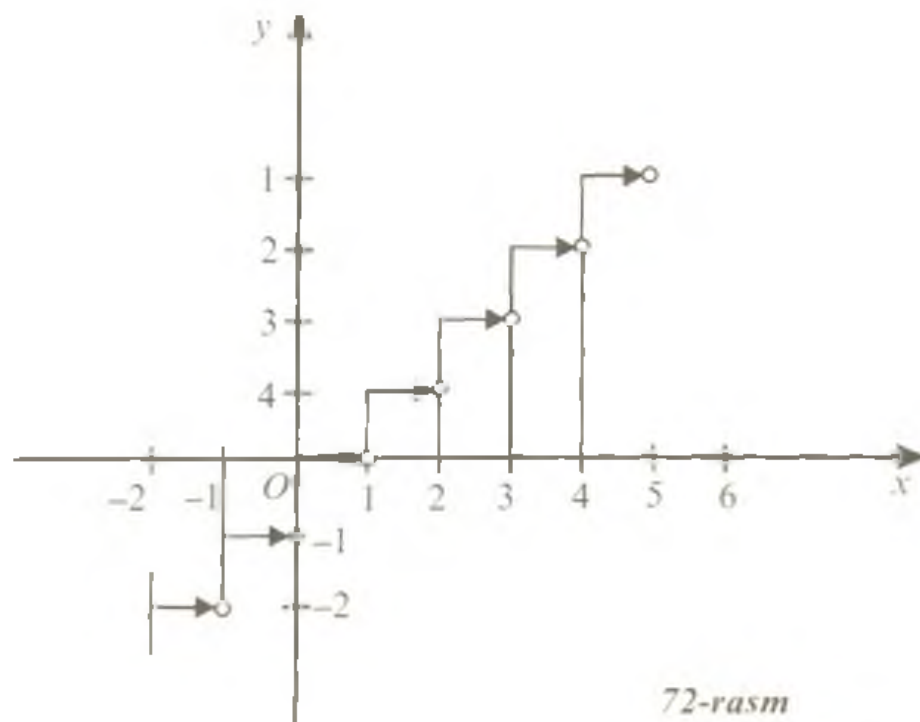

72-rasm

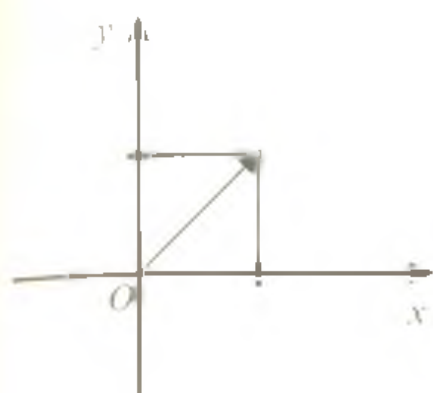

73-rasm

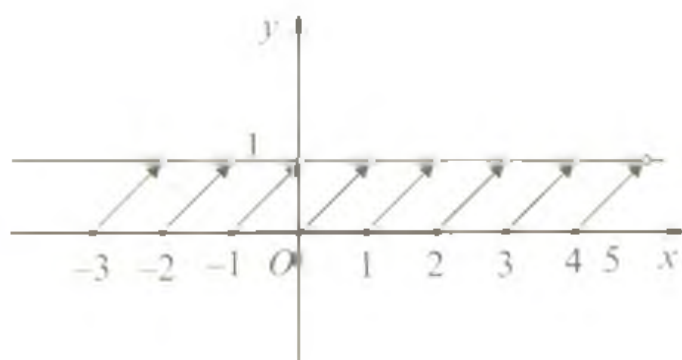

74-rasm

$y = [x]$  funksiya grafigi 72-rasmda tasvirlangan.

Bu funksiya grafigi birlik oraliqlarning cheksiz to'plamidan iborat, bu oraliqlarning chap oxiri tegishli bo'lib, o'ng oxiri tegishli emas.

$y = \{x\}$  funksiya grafigini yasaymiz. Bu funksiya grafigini yasashda

$$\{x + 1\} = \{x\},$$

ya'ni ixtiyoriy  $x$  songa 1 qo'shilsa, bu sonning faqat butun qismi o'zgarib, kasr qismi o'zgarmasdan qolishini nazarda tutib, dastlab grafikning uzunligi 1 ga teng bo'lgan istalgan, masalan,  $[0; 1)$  oraliqdagi tarmog'ini yasash yetarlidir. Agar  $0 \leq x < 1$  bo'lsa,  $[x] = 0$ , shuning uchun  $\{x\} = x$ .

73-rasmda  $y = \{x\}$  funksiyaning  $[0; 1)$  oraliqdagi, 74-rasmda esa  $y = \{x\}$  funksiyaning butun sonlar o'qidagi grafigi tasvirlangan. Bu funksiya davri 1 ga teng bo'lgan davriy funksiya.

### 5-§. Funksiyalar grafiklarini geometrik almashtirish

Agar  $y = f(x)$  funksiya grafigi ma'lum bo'lsa, tekislikdagi ayrim almashtirishlar (parallel ko'chirish, to'g'ri chiziqqa nisbatan simmetriya, nuqtaga nisbatan simmetriya va h.k.) yordamida murakkabroq  $y = f(bx)$ ,  $y = f(x + c)$ ,  $y = af(x)$ ,  $y = f(x) + k$ ,  $y = f(-x)$ ,  $y = |f(x)|$  va  $y = f(|x|)$  kabi funksiyalarning grafiklarini yasash mumkin.

1.  $f(bx)$  funksiya grafigi  $f(x)$  funksiya grafigini,  $b > 1$  bo'lsa,  $Oy$  o'qiga  $b$  marta siqish, agar  $0 < b < 1$  bo'lsa,  $Oy$  o'qida  $\frac{1}{b}$  marta cho'zish yo'li bilan hosil qilinadi (75-rasm).



2.  $f(x + c)$  funksiya grafigi  $f(x)$  funksiya grafigini  $c > 0$  bo'lsa,  $Ox$  o'qining manfiy yo'nalishi bo'yicha,  $c < 0$  bo'lsa, musbat yo'nalishi bo'yicha  $|c|$  ga parallel ko'chirish yordamida hosil qilinadi (76-rasm).

3.  $af(x)$  funksiya grafigi  $f(x)$  funksiya grafigini  $a > 1$  bo'lsa,  $Oy$  o'qi bo'yicha  $a$  marta cho'zish,  $0 < a < 1$  bo'lsa  $\frac{1}{a}$  marta siqish yordamida hosil qilinadi (77-rasm).

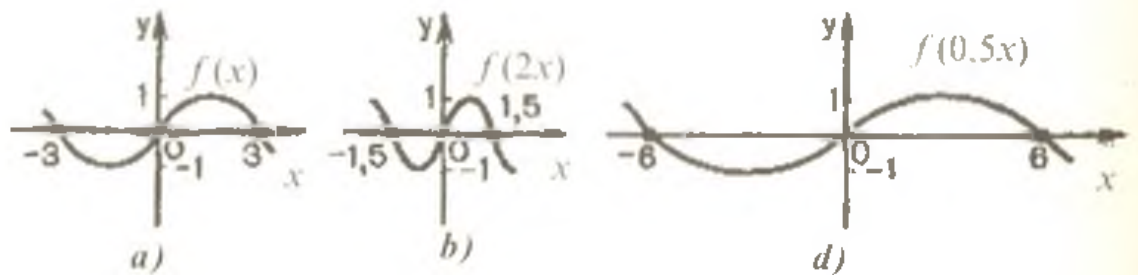

75-rasm.

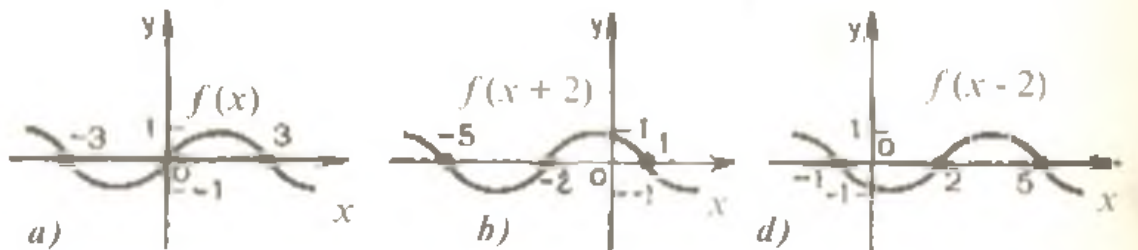

76-rasm

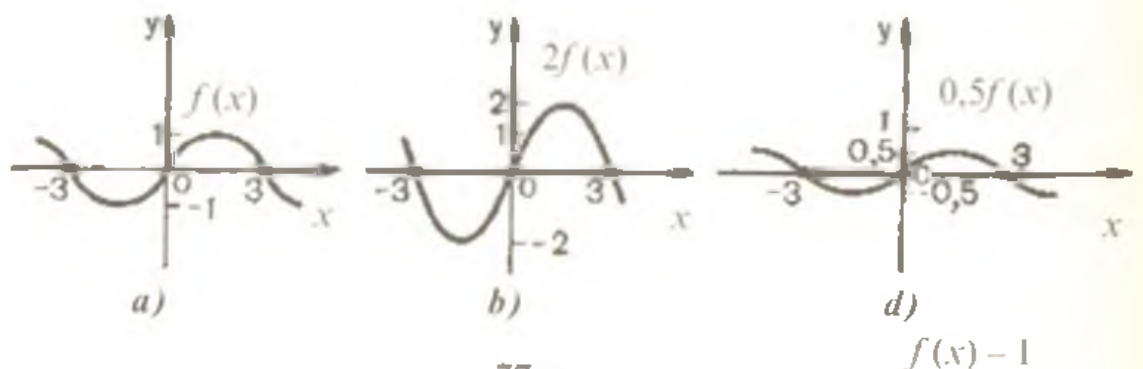

77-rasm

4.  $f(x) + k$  funksiya grafigi  $f(x)$  funksiya grafigini  $k > 0$  bo'lsa,  $Oy$  o'qining musbat yo'nalishi bo'yicha,  $k < 0$  bo'lsa,  $Oy$  o'qining manfiy yo'nalishi bo'yicha  $|k|$  qadar parallel ko'chirish yordamida hosil qilinadi (78-rasm).

5.  $y = f(-x)$  funksiya grafigi  $f(x)$  funksiya grafigini  $Oy$  o'qiga nisbatan simmetrik akslantirish natijasida hosil qilinadi (79-rasm).

6.  $y = -f(x)$  funksiya grafigi  $f(x)$  funksiya grafigini  $Ox$  o'qiga nisbatan simmetrik akslantirish yordamida hosil qilinadi (80-rasm).

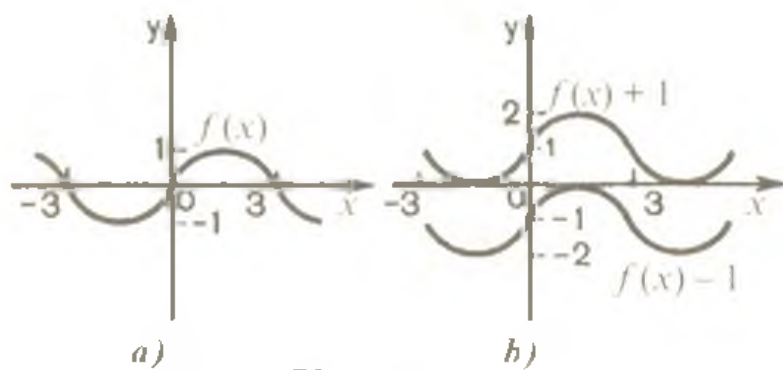

78-rasm

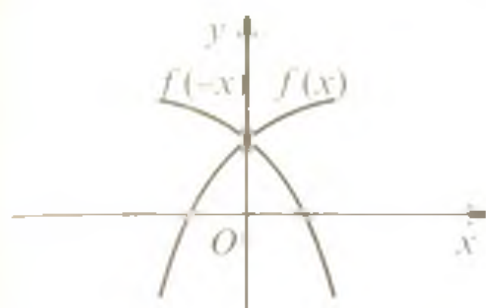

79-rasm

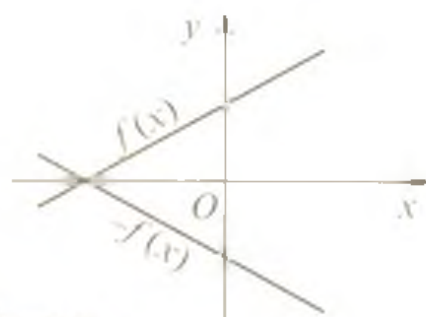

80-rasm

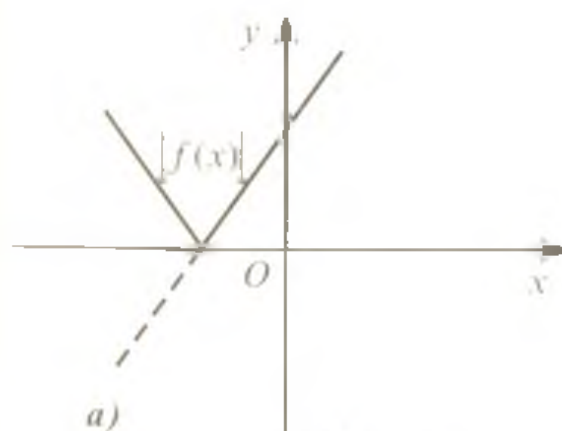

81-rasm

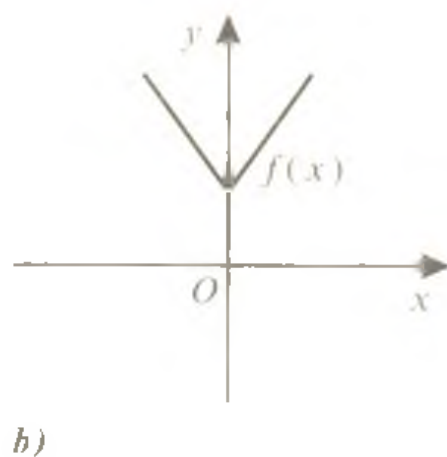

82-rasm

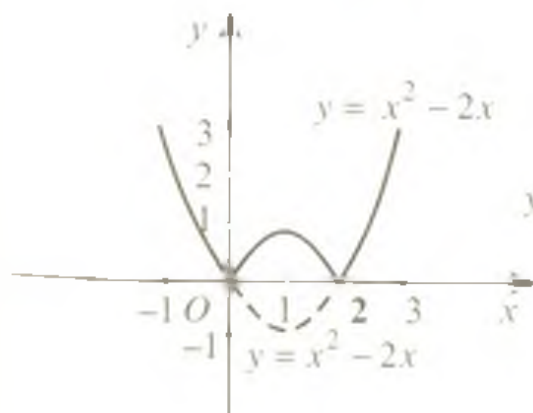

83-rasm

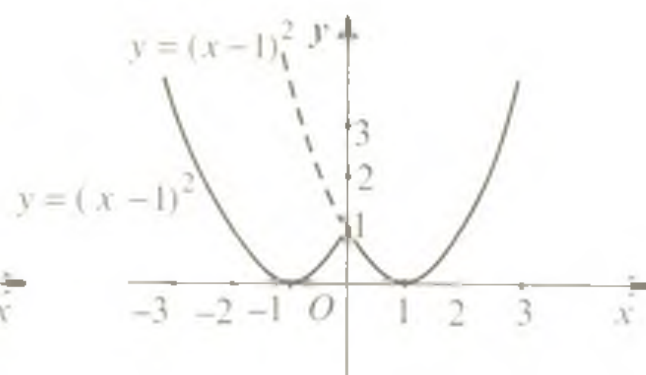

84-rasm

7.  $y = |f(x)|$  funksiya grafigini  $f(x)$  funksiya grafigidan foydalanib yasash

$$|f(x)| = \begin{cases} f(x), & \text{agar } f(x) \geq 0, \\ -f(x), & \text{agar } f(x) < 0 \end{cases}$$

ekanligiga asoslandi. Shu sababli  $y = f(x)$  funksiya grafigining  $Ox$  o'qidan yuqoridagi qismi saqlanib,  $Ox$  o'qidan pastki qismi shu o'qqa nisbatan simmetrik akslantiriladi (81-rasm).

8.  $y = f(|x|)$  grafigini yasashda

$$f(x) = \begin{cases} f(x), & \text{agar } f(x) \geq 0, \\ f(-x), & \text{agar } f(x) < 0 \end{cases}$$

tenglikka ko'ra avval  $x \geq 0$  uchun  $f(x)$  funksiya grafigi chiziladi va hosil qilingan grafik  $x < 0$  uchun  $Oy$  o'qiga nisbatan simmetrik akslantiriladi (82-rasm).

83-va 84-rasmlarda  $y = |x^2 - 2x|$  va  $y = (|x| - 1)^2$  funksiyalarning grafiglari tasvirlangan.

### 6-§. $y = x^n$ funksiyaning xossalari va grafigi

$y = x^n$  funksiya (bu yerda  $n \in \mathbb{N}$ ) *natural ko'rsatkichli darajali funksiya* deyiladi.  $n = 1$  da  $y = x$  funksiya hosil bo'ladi, uning xossalari va grafigi IV bob 4-§ da qaralgan edi.  $n = 2$  da  $y = x^2$  funksiyaning hosil qilamiz, uning xossalari va grafigi V bob 2-§ da keltirilgan.

**6.1.  $y = x^3$  funksiya.** Bu funksiya quyidagi xossalarga ega:

1. Funksiyaning aniqlanish sohasi haqiqiy sonlar to'plamidan iborat:  $(-\infty; +\infty)$ .

2.  $y = x^3$  - toq funksiya ( $f(-x) = (-x^3) = -x^3 = -f(x)$ ).

3.  $y = x^3$  - funksiya o'suvchi.

$y = x^3$  funksiyaning grafigi 85-rasmda tasvirlangan. U *kubik parabola* deyiladi.

**6.2.  $y = x^{2n}$  funksiya.**  $y = x^n$  formulada  $n$  ikkidan katta istalgan juft natural son bo'lsin:  $n = 4, 6, 8, \dots$ . Bu holda  $y = x^{2n}$  funksiya  $y = x^2$  funksiya ega bo'lgan xossalarga ega bo'ladi (faqat grafikning tarmoqlari  $|x| > 1$  da  $n$  kattalashgan sari tikroq bo'la boradi (86-rasm).

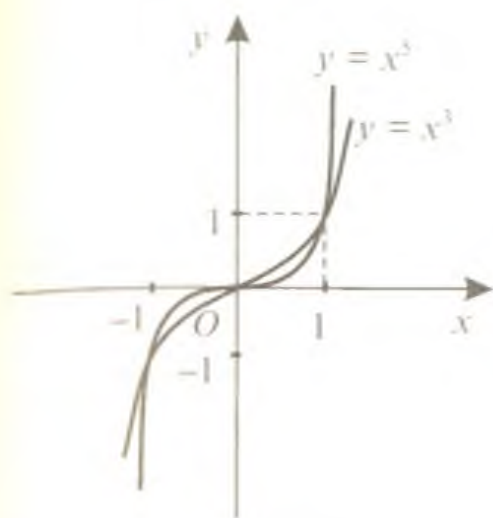

85-rasm

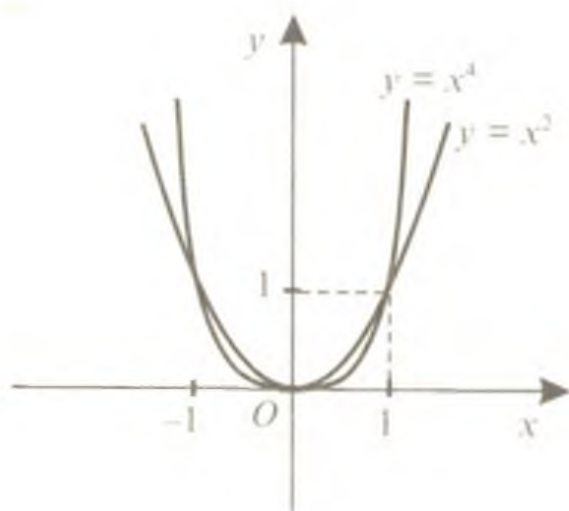

86-rasm

**6.3.  $y = x^{2n+1}$  funksiya.**  $y = x^n$  formulada  $n$  uchdan katta istalgan toq son bo'lsin:  $n = 5, 7, 9 \dots$  Bu holda  $y = x^{2n+1}$  funksiya  $y = x^3$  funksiyaga ega bo'lgan xossalarga ega bo'ladi. Bunday funksiyalar grafiği kubik parabola shaklida bo'lib,  $n$  ortgan sari yuqoriga (pastga) tikroq bo'la boradi (85-rasm).

Umuman,  $n > 2$  da  $y = x^n$  funksiya grafiği  $n$ -darajali parabola deb ataladi. Bu funksiyalarning grafiğlari  $(0; 1)$  oraliqda  $n$  ortishi bilan  $x$  kattalashgan sari  $Ox$  o'qidan shunchalik sekin uzoqlasha boradi.

### 7-§. $y = \frac{k}{x}$ funksiya va uning grafiği

**7.1.** Agar o'zgaruvchi  $y$  o'zgaruvchi  $x$  ga proporsional bo'lsa, u holda bunday bog'lanish  $y = kx$  formula bilan ifodalanadi, bunda  $k \neq 0$  – proporsionallik koeffitsiyenti deyiladi. Bu funksiya grafiği IV bob 4-§ keltirilgan.

**7.2.** Agar o'zgaruvchi  $y$  o'zgaruvchi  $x$  ga teskari proporsional bo'lsa, u holda ular orasidagi bog'lanish

$$y = \frac{k}{x}$$

formula bilan ifodalanadi, bunda  $k \neq 0$  – teskari proporsionallik koeffitsiyenti deyiladi.

**7.3.  $y = \frac{k}{x}$  funksiya xossalari va grafiği.**

1. Funksiyaning aniqlanish sohasi noldan tashqari barcha haqiqiy sonlar to'plamidan iborat:  $(-\infty; 0) \cup (0; +\infty)$ .

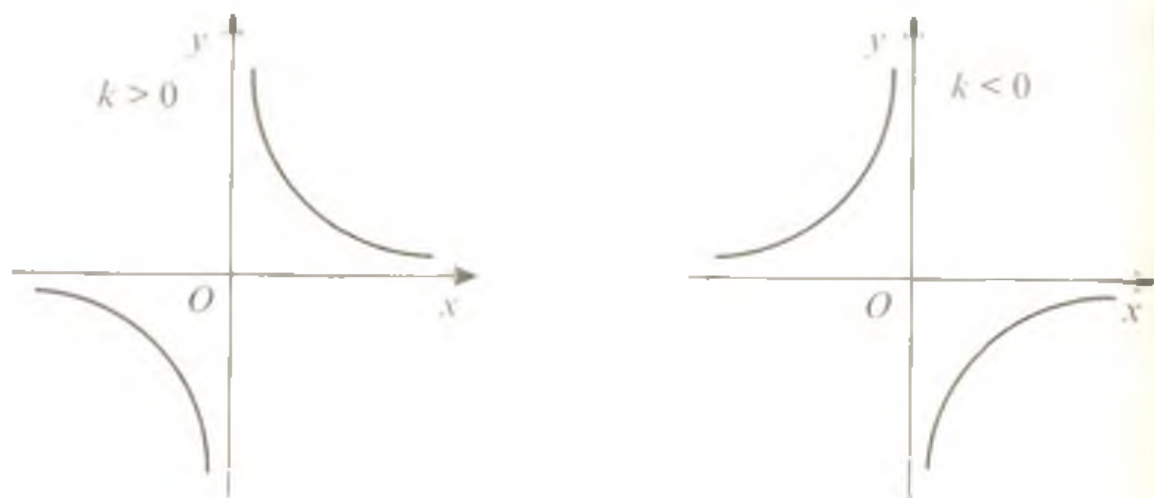

87-rasm

2. Funksiya toq, chunki  $f(-x) = \frac{k}{-x} = -\frac{k}{x} = -f(x)$ .
3. Agar  $k > 0$  bo'lsa, funksiya o'zining aniqlanish sohasida kamayadi, agar  $k < 0$  bo'lsa, o'sadi.
4.  $y = \frac{k}{x}$  funksiya grafigi koordinata boshiga nisbatan simmetrik, ikki tarmoqli egri chiziqdan iborat. Bunday egri chiziq *giperbola* deyiladi (87-rasm). Agar  $k > 0$  bo'lsa, giperbola tarmoqlari I va III choraklarda,  $k < 0$  bo'lsa, II va IV choraklarda joylashgan bo'ladi. Giperbola koordinata o'qlari bilan umumiy nuqtaga ega emas.

### 8-§. Kasr-chiziqli funksiya va uning grafigi

$y = \frac{ax+b}{cx+d}$  ko'rinishdagi funksiya *kasr-chiziqli funksiya* deyiladi, bunda  $a, b, c, d$  - berilgan sonlar,  $c \neq 0$  (aks holda chiziqli funksiyaga ega bo'lamiz) va  $ad \neq bc$  (agar  $ad = bc$  bo'lsa,  $y = \text{const}$ ).

**8.1.** Funksiya sonlar o'qining  $x = -\frac{d}{c}$  nuqtasidan tashqari barcha nuqtalarida aniqlangan.

**8.2.** Funksiya grafigini yasash uchun uning ifodasida butun qismini ajratib, quyidagi shakl almashtirishlarni bajaramiz:

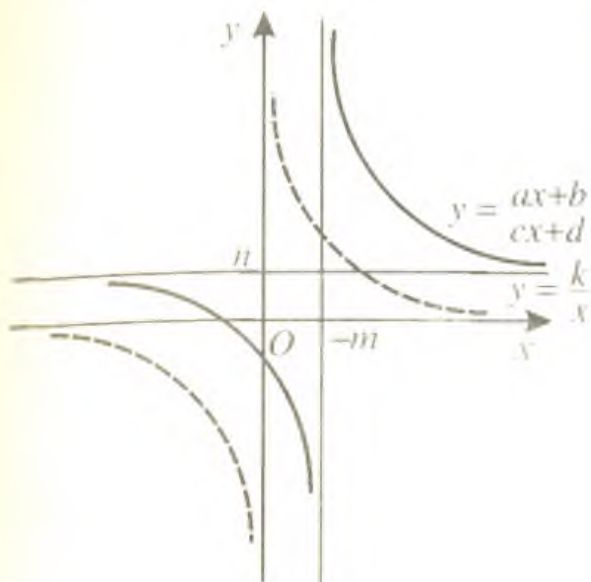

88-rasm

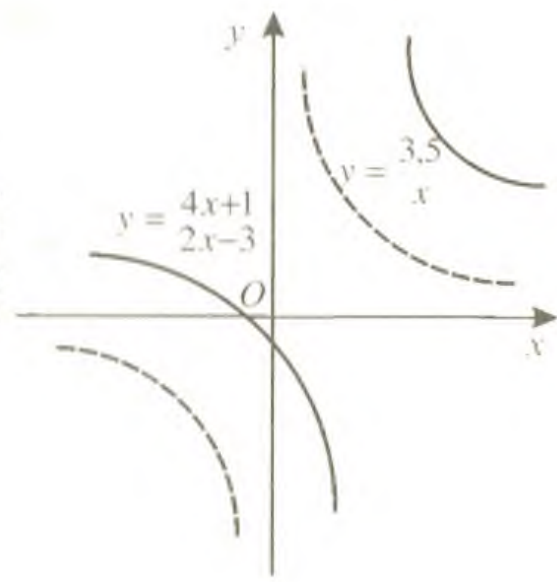

89-rasm

$$\begin{aligned}
 y = \frac{ax+b}{cx+d} &= \frac{a\left(x+\frac{d}{c}-\frac{d}{c}\right)+b}{c\left(x+\frac{d}{c}\right)} = \frac{a\left(x+\frac{d}{c}\right)+\left(b-\frac{ad}{c}\right)}{c\left(x+\frac{d}{c}\right)} = \\
 &= \frac{a\left(x+\frac{d}{c}\right)}{c\left(x+\frac{d}{c}\right)} + \frac{b-\frac{ad}{c}}{c\left(x+\frac{d}{c}\right)} = \frac{a}{c} + \frac{bc-ad}{c^2\left(x+\frac{d}{c}\right)},
 \end{aligned}$$

Bu yerda  $k = \frac{bc-ad}{c^2}$ ,  $m = \frac{d}{c}$  va  $n = \frac{a}{c}$  belgilashlar kiritib, berilgan kasr-chiziqli funktsiyani

$$y = n + \frac{k}{x+m}$$

shaklga keltiramiz.

8.3. 5-§ da keltirilgan qoidalarga ko'ra

$$y = n + \frac{k}{x+m}$$

funktsiya grafisini  $y = \frac{k}{x}$  giperbolani  $Ox$  o'qi bo'ylab  $|m|$  birlikka va  $Oy$  o'qi bo'ylab  $|n|$  birlikka ko'chirish yordamida hosil qilish mumkin. Ko'chirishning qanday yo'nalishda amalga oshirilishi  $m$  va  $n$  larning ishorasiga bog'liq (88-rasm).

8.4. Funktsiya grafisini aniqroq yasash uchun uni koordinata o'qlari bilan kesishish nuqtalarini aniqlash maqsadga muvofiqdir.

Masala.  $y = \frac{4x+1}{2x-3}$  funktsiya grafisini yasang.

Yechilishi. Berilgan funksiya grafigini yasash uchun avval uning butun qismini ajratamiz:

$$y = \frac{4x+1}{2x-3} = \frac{4x+1}{2\left(x-\frac{3}{2}\right)} = \frac{4\left(x-\frac{3}{2}+\frac{3}{2}\right)+1}{2\left(x-\frac{3}{2}\right)} =$$

$$= \frac{4\left(x-\frac{3}{2}\right)+7}{2\left(x-\frac{3}{2}\right)} = \frac{4(x-1,5)+7}{2(x-1,5)} = 2 + \frac{3,5}{x-1,5}$$

Funksiya grafigini  $Ox$  va  $Oy$  o'qlari bilan kesishish nuqtalarini topamiz:

$$x = 0 \text{ da } y = 2 - \frac{3,5}{1,5} = 2 - \frac{7}{3} = -\frac{1}{3} \quad [y = -\frac{1}{3}]$$

$$y = 0 \text{ da } 0 = 2 + \frac{3,5}{x-1,5} \Leftrightarrow 2x-3+3,5 = 0 \Rightarrow [x = -\frac{1}{4}]$$

Shunday qilib, berilgan funksiya grafigini tasvirlovchi giperbola  $Ox$  o'qini  $A(-\frac{1}{4}; 0)$  nuqtada,  $Oy$  o'qini  $C(0; -\frac{1}{3})$  nuqtada kesib

o'tadi. Funksiya grafigi 89-rasmda tasvirlangan. Bu grafik  $y = \frac{3,5}{x}$  funksiya grafigini  $Ox$  o'qi bo'ylab 1,5 birlikka,  $Oy$  o'qi bo'ylab 2 birlikka musbat yo'nalishda siljitish natijasida hosil qilindi.

## 9-§. $y = |x|$ va $y = |ax + b| + |cx + d|$ funksiyalar grafiglari

9.1.  $y = |x|$  funksiya. Bilamizki,

$$|x| = \begin{cases} x, & \text{agar } x \geq 0 \text{ bo'lsa,} \\ -x, & \text{agar } x < 0 \text{ bo'lsa.} \end{cases}$$

Bu funksiya quyidagi xossalarga ega.

1. Aniqlanish sohasi haqiqiy sonlar to'plamidan iborat.
2.  $y = |x|$  funksiya juft funksiya.
3.  $x < 0$  da kamayuvchi,  $x > 0$  da o'suvchi.

Agar  $x \geq 0$  bo'lsa,  $|x| = x$  bo'lganligi uchun  $y = |x|$  funksiya grafigi birinchi koordinata burchagining bissektrisasi bo'ladi. Agar  $x < 0$  bo'lsa, u holda  $|x| = -x$  bo'ladi va manfiy  $x$  lar uchun funksiya grafigi ikkinchi koordinata burchagining bissektrisasi bo'ladi. Istalgan  $x$

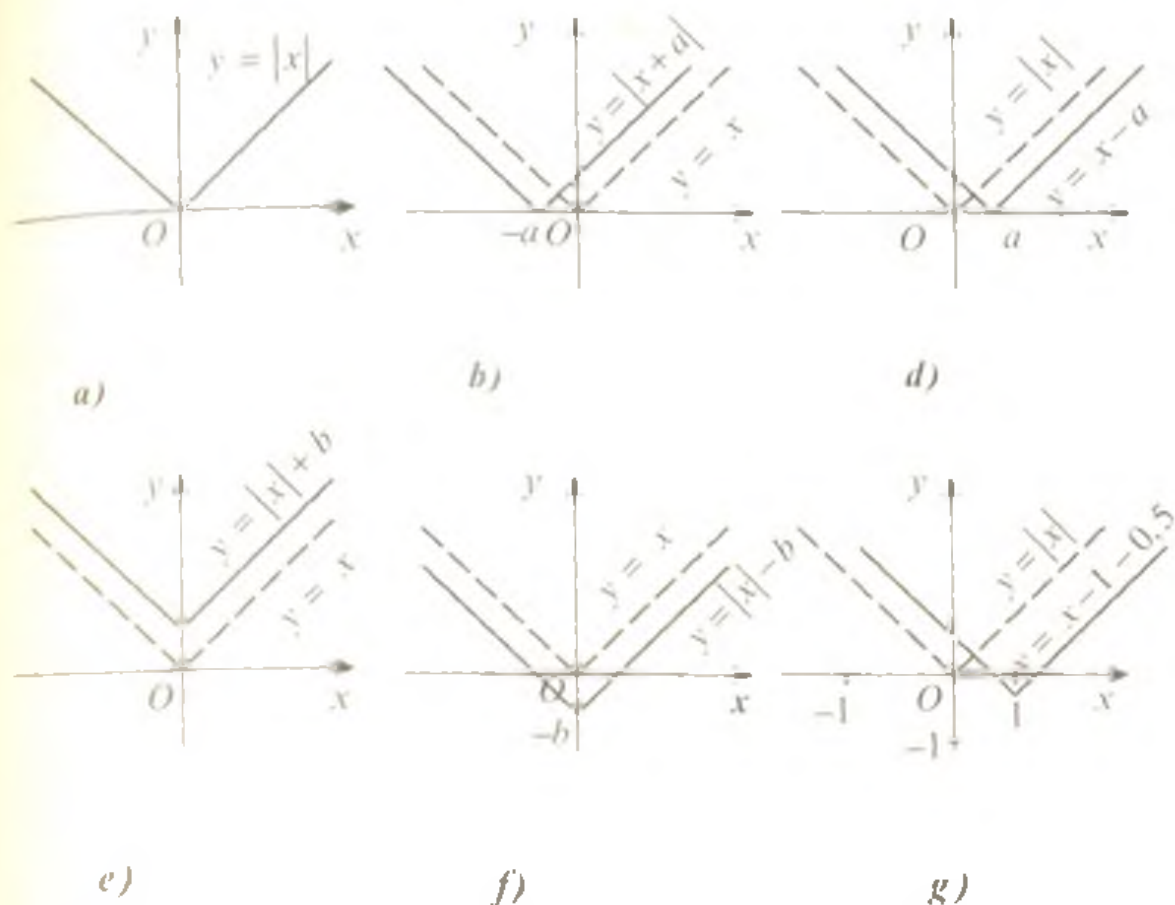

90-rasm

uchun  $|-x| = |x|$ . Shuning uchun  $y = |x|$  funksiyaning grafigi ordinatalar o'qiga nisbatan simmetrik bo'ladi (90-a rasm).

$y = |x + a|$  funksiya grafigi  $y = |x|$  funksiya grafigini  $a > 0$  bo'lsa,  $a$  birlikka  $Ox$  o'qi bo'ylab chapga,  $a < 0$  bo'lsa,  $|a|$  birlikka o'ngga siljitish natijasida hosil qilinadi (90-b, d rasmlar).  $y = |x| + b$  funksiya grafigi esa  $b > 0$  bo'lsa,  $y = |x|$  funksiya grafigini  $Oy$  o'qi bo'ylab  $b$  birlik yuqoriga,  $b < 0$  bo'lsa,  $|b|$  birlik pastga ko'chirish yordamida hosil qilinadi (90-e, f rasmlar). 90-g rasmda

$$y = |x - 1| - 0,5$$

funksiya grafigi tasvirlangan.

**9.2.  $y = |ax + b| + |cx + d|$  funksiya grafigi.** Bu funksiyaning aniqlanish sohasi haqiqiy sonlar to'plamidan iborat bo'lib, uning grafigini yasashda oraliqlar usulidan foydalanish maqsadga muvofiqdir. Bu usulga ko'ra  $|ax + b|$  va  $|cx + d|$  qo'shiluvchilarning ishoralari o'zgarmaydigan oraliqlar topiladi. Bunday oraliqlar  $x = -\frac{b}{a}$  va  $x = -\frac{d}{c}$  nuqtalar yordamida hosil qilinadi. Hosil qilingan oraliqlar uchun funksiya ifodasini yozib, so'ngra grafigi yasaladi. Bu usulni





91-rasm

$y = |x - 5| + |x - 2|$   
 funksiya grafigini yasash  
 misolida ko'rib chiqamiz.

Yechilishi. Sonlar  
 o'qini  $x = 2$  va  $x = 5$   
 nuqtalar yordamida  $(-\infty; 2)$ ,  
 $[2; 5)$  va  $[5; +\infty)$  oraliqlarga  
 ajratamiz. Har bir oraliqda  
 modul belgisi ostidagi  
 ifodalar ishoralarini tekshi-  
 rib, funksiya ifodasini  
 yozamiz.

1)  $x \in (-\infty; 2)$  uchun  $x - 5 < 0$ ,  $x - 2 < 0$  bo'ladi.  $y = -x + 5 - x + 2 = -2x + 7$ ;

2)  $x \in [2; 5)$  uchun  $x - 5 < 0$ ,  $x - 2 \geq 0$  bo'ladi.  $y = -x + 5 + x - 2 = 3$ ;

3)  $x \in [5; +\infty)$  uchun  $x - 5 \geq 0$ ,  $x - 2 > 0$  bo'ladi.  $y = x - 5 + x - 2 = 2x - 7$ .

Shunday qilib,

$$y = |x - 5| + |x - 2| = \begin{cases} -2x + 7, & \text{agar } x < 2 \text{ bo'lsa,} \\ 3, & \text{agar } 2 \leq x < 5 \text{ bo'lsa,} \\ 2x - 7, & \text{agar } x \geq 5 \text{ bo'lsa.} \end{cases}$$

Funksiya grafigi 91-rasmda tasvirlangan. Bu funksiyaning qiymatlar to'plami  $[3; +\infty)$ .

### 10- §. Teskari funksiya. Teskari funksiyaning grafigi

**10.1. Teskari funksiya tushunchasi.**  $y = f(x)$  tenglik  $x$  o'zgaruvchi miqdorning qabul qilishi mumkin bo'lgan har bir qiymatiga  $y$  o'zgaruvchi miqdorning to'la aniqlangan qiymatini mos keltiradi. Agar  $y = f(x)$  tenglikka asosan,  $y$  miqdorning qabul qilishi mumkin bo'lgan har bir qiymati bo'yicha  $x$  miqdorning faqat bitta qiymatini tiklash mumkin bo'lsa, u holda bu tenglikdan  $x$  ni  $y$  ning funksiyasi kabi aniqlash mumkin. Bu funksiyaning  $\varphi$  harfi bilan belgilaymiz:

$$x = \varphi(y).$$

Bu tenglikda  $y$  argument,  $x$  esa funksiya bo'lib kelayapti. Argumentni  $x$  harfi bilan, funktsiyani  $y$  harfi bilan belgilash odat tusiga kirib qolganligi uchun  $\varphi$  harfi bilan belgilangan funksional bog'lanish

$$y = \varphi(x)$$

ko'rinishda yoziladi. Shunday aniqlangan  $y = \varphi(x)$  funksiya  $y = f(x)$  funksiyaga nisbatan *teskari funksiya* deyiladi.

Umuman, agar funksiya  $y = f(x)$  tenglik bilan berilgan bo'lsa, u holda teskari funktsiyani topish uchun  $f(x) = y$  tenglamani  $x$  ga nisbatan yechish hamda  $x$  va  $y$  larning o'rinlarini almashtirish kerak.

Agar  $f(x) = y$  tenglama bittadan ortiq ildizga ega bo'lsa, u holda  $y = f(x)$  funksiyaga teskari funksiya mavjud emas.

Grafiqi 92-a rasmda keltirilgan  $y = f(x)$  funksiyaning teskari funksiyasi mavjud, 92-b rasmda grafiqi tasvirlangan  $y = g(x)$  funksiyaning esa teskari funksiyasi mavjud emas.

Agar  $y = f(x)$  funksiya shunday bo'lsaki, uning istalgan  $y_0$  qiymati uchun  $f(x) = y_0$  tenglama  $x$  ga nisbatan yagona ildizga esa bo'lsa, bunday funksiya *teskarilamuvchan funksiya* deyiladi.

92-rasmda keltirilgan  $y = f(x)$  va  $y = g(x)$  funksiyalarning grafiklarini taqqoslab,  $y = f(x)$  funksiya o'suvchi ekanini,  $y = g(x)$  funksiya esa o'suvchi ham emas, kamayuvchi ham emasligini ko'ramiz.

Agar  $y = f(x)$  funksiya  $X$  oraliqda aniqlangan hamda o'suvchi (kamayuvchi) bo'lsa va uning qiymatlar sohasi  $Y$  dan iborat bo'lsa, uning teskari funksiyasi mavjuddir. Bu teskari funksiya  $Y$  da aniqlangan va o'suvchi (kamayuvchi) bo'ladi.

Teskari funksiyaning aniqlanish sohasi dastlabki funksiyaning qiymatlar to'plami bilan, teskari funksiyaning qiymatlar to'plami esa dastlabki funksiyaning aniqlanish sohasi bilan ustma-ust tushadi.

1-misol.  $y = 2x + 1$  funksiyaga teskari funktsiyani toping.

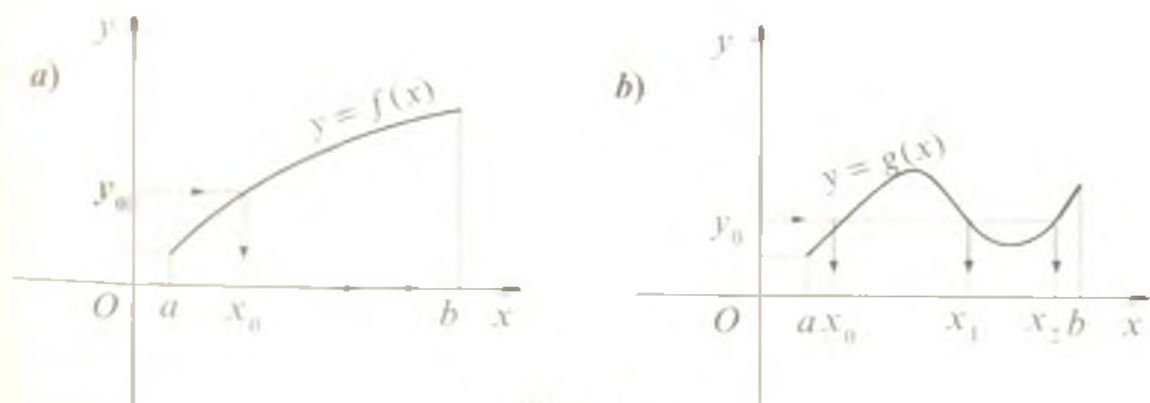

92-rasm

Yechilishi.  $y = 2x + 1$  funksiya sonlar o'qining barcha nuqtalarida o'sadi, demak, uning teskari funksiyasi mavjud. Bu teskari funksiyani topish uchun

$$2x + 1 = y$$

tenglamani  $x$  ga nisbatan yechamiz:

$$x = \frac{1}{2}y - \frac{1}{2}.$$

Bu tenglikda  $x$  va  $y$  larning o'rinlarini almashtirib,

$$y = \frac{1}{2}x - \frac{1}{2}$$

funksiyani hosil qilamiz. Bu izlanayotgan teskari funksiya bo'lib, bu funksiya ham sonlar o'qining barcha nuqtalarida o'sadi.

$$\text{Javob: } y = \frac{1}{2}x - \frac{1}{2}.$$

2-misol.  $y = \frac{3}{x-3} - 1$  funksiyaning teskari funksiyasini toping.

Yechilishi. Berilgan funksiya o'zgaruvchi  $x$  ning 3 dan boshqa barcha qiymatlarida aniqlangan, o'zining aniqlanish sohasida kamayuvchi funksiyadir. Uning teskari funksiyasini topamiz:

$$\frac{3}{x-3} - 1 = y \Leftrightarrow 3 - (x-3) = y(x-3) \Leftrightarrow$$

$$\Leftrightarrow y(x-3) + (x-3) = 3 \Leftrightarrow (x-3)(y+1) = 3 \Leftrightarrow$$

$$\Leftrightarrow x-3 = \frac{3}{y+1} \Rightarrow \left[ x = \frac{3}{y+1} + 3. \right.$$

$x$  va  $y$  larning o'rinlarini almashtirsak,

$$y = \frac{3}{x+1} + 3$$

teskari funksiya hosil bo'ladi.

Bu misolda  $y = \frac{3}{x-3} - 1$  funksiyaning aniqlanish sohasi:

$x \in (-\infty; 3) \cup (3; +\infty)$ , qiymatlar to'plami:  $x \in (-\infty; -1) \cup (-1; +\infty)$ .

Teskari funksiya  $y = \frac{3}{x+1} + 3$  ning aniqlanish sohasi:

$x \in (-\infty; -1) \cup (-1; +\infty)$ , qiymatlar to'plami:  $x \in (-\infty; 3) \cup (3; +\infty)$ .

$$\text{Javob: } y = \frac{3}{x+1} + 3.$$

**10.2. Teskari funksiyaning grafigi.** Agar koordinatalari  $(x; y)$  bo'lgan nuqta  $y = f(x)$  funksiya grafigiga tegishli bo'lsa, koordinatalari  $(y; x)$

bo'lgan nuqta esa teskari funksiya grafigiga tegishli bo'ladi. Shuning uchun teskari funksiya grafigi  $y = f(x)$  funksiya grafigini  $Oxy$  tekislikdagi  $(x; y)$  nuqtani  $(y; x)$  nuqtaga o'tkazadigan almashtirish orqali hosil qilinadi. Bu almashtirish  $y = x$  to'g'ri chiziqqa nisbatan simmetrikdir.

Shunday qilib,  $y = f(x)$

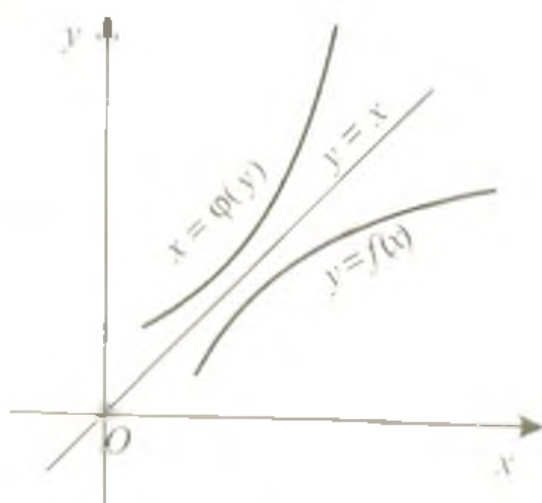

93-rasm

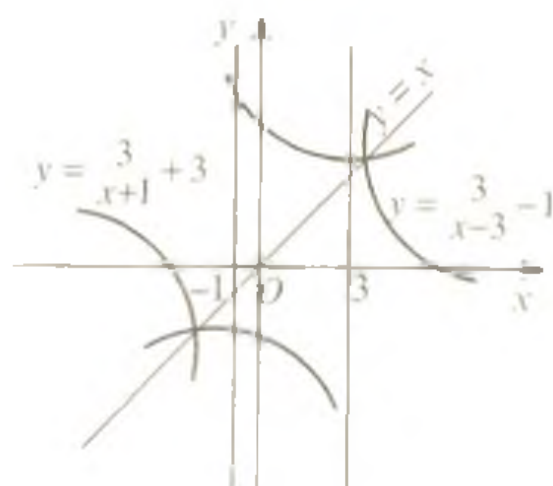
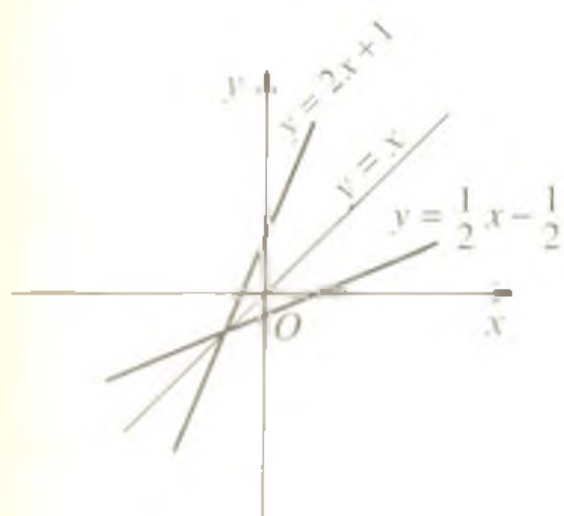

94-rasm

funksiyaga teskari funksiya grafigini yasash uchun  $y = f(x)$  funksiya grafigini  $y = x$  to'g'ri chiziqqa nisbatan simmetrik almashtirish kerak (93-rasm).

94-rasmda 1, 2- misollarda qaralgan funksiyalarning grafilari tasvirlangan.

### Mustaqil ishlash uchun test topshiriqlari

1.  $f(x) = \frac{3-x^2}{x+2} - \frac{1}{4}$  funksiyaning  $x = 2$  nuqtadagi qiymatini toping.

A) 0;      B)  $-\frac{1}{4}$ ;      C)  $\frac{1}{2}$ ;      D)  $-\frac{1}{2}$ ;      E)  $\frac{1}{4}$ .

2. Quyidagi nuqtalardan qaysi biri  $f(x) = x^2 - 2x + 0,5$  funksiyaning grafigiga tegishli?

- A) (2; 0.5); B) (0; -0.5); C) (1; 0.5); D) (2; -0.5); E) (1; 0).
3. Agar  $f(x-1) = x^2 - 2x - 2$  bo'lsa,  $f(x)$  ni toping.  
 A)  $f(x) = x^2 + 3$ ; B)  $f(x) = x^2 + 2$ ; C)  $f(x) = x^2 - 2$ ;  
 D)  $f(x) = x^2 - 3$ ; E)  $f(x) = x^2 - 4$ .
4.  $a$  ning qanday qiymatlarida  $f(x) = ax^2 + 3x - 6$  va  $f(x) = 2x - 1$  funksiyalar kesishadi?  
 A)  $[-0.5; +\infty)$ ; B)  $[-0.05; +\infty)$ ; C)  $(-\infty; +\infty)$ ;  
 D)  $[1; 20]$ ; E)  $[0.05; +\infty)$ .
5. Agar  $f(x+1) = x^2 + 2x + 2$  bo'lsa,  $f(x)$  ni toping.  
 A)  $x^2 - 1$ ; B)  $2x + 1$ ; C)  $x^2 + 1$ ; D)  $x^2 + 2x + 1$ ; E)  $x^2 - 2x + 1$ .
6.  $y = \sqrt{-x} - \frac{4}{\sqrt{8+x}}$  funksiyaning aniqlanish sohasini toping.  
 A)  $[0; +\infty)$ ; B)  $(-\infty; 0]$ ; C)  $(-\infty; 0]$ ;  
 D)  $(-\infty; -8]$ ; E)  $(-\infty; -8) \cup (-8; +\infty)$ .
7.  $y = \frac{1}{\sqrt{|x|-2}|x-1|}$  funksiyaning aniqlanish sohasiga tegishli butun sonlar nechta?  
 A) yo'q; B) 1; C) 2; D) 3; E) 4.
8.  $y = \sqrt{x^2 - 4} - \sqrt{x - 2} - \sqrt{2 - x}$  funksiyaning aniqlanish sohasini toping.  
 A)  $(-\infty; -2] \cup [2; +\infty)$ ; B)  $(-2; 2)$ ; C)  $(-\infty; -2)$ ;  
 D)  $\{2\}$ ; E)  $\emptyset$ .
9. Agar  $f(x) = \begin{cases} x^2, & -1 \leq x < 0, \\ -2x + 1, & 0 \leq x < \frac{1}{2}, \\ \cos \pi x, & \frac{1}{2} \leq x \leq 1 \end{cases}$  bo'lsa,  $f\left(-\frac{1}{2}\right)$  ni hisoblang.  
 A)  $-\frac{1}{4}$ ; B)  $\frac{1}{4}$ ; C) 2; D) 0; E)  $-\frac{1}{2}$ .
10.  $y = \frac{2x+3}{x^2-9}$  funksiyaning aniqlanish sohasini toping.  
 A)  $(-\infty; 3) \cup (3; +\infty)$ ; B)  $(0; +\infty)$ ; C)  $(-3; 3)$ ;  
 D)  $(-\infty; 0)$ ; E)  $(-\infty; -3) \cup (-3; 3) \cup (3; +\infty)$ .
11.  $y = \frac{4x^2}{x^3-4x} + x$  funksiyaning aniqlanish sohasini toping.

- A)  $(-\infty; -2) \cup (-2; 2) \cup (2; +\infty)$ ;      B)  $(-2; 0) \cup (0; 2)$ ;  
 C)  $(-\infty; -2) \cup (-2; 0) \cup (0; 2) \cup (2; +\infty)$ ;      D)  $(-\infty; -2) \cup (2; +\infty)$ ;  
 E)  $(2; +\infty)$ .

12.  $f(x) = \sqrt{2-x} + \sqrt{x^2-4} + 5$  funksiyaning aniqlanish sohasini toping.

- A)  $(-\infty; -2] \cup \{2\}$ ;      B)  $(-\infty; -2]$ ;      C)  $(-\infty; 2]$ ;  
 D)  $(-\infty; -2] \cup [2; +\infty)$ ;      E)  $\{2\}$ .

13.  $y = \sqrt{\frac{x-1}{x+1}} + \sqrt{2-x}$  funksiyaning aniqlanish sohasiga tegishli eng katta manfiy butun sonni toping.

- A) bunday son yo'q;      B)  $-2$ ;      C)  $-1$ ;      D)  $-3$ ;      E)  $-10$ .

14.  $y = x^2 + 2x$  funksiyaning qiymatlar to'plamini toping.

- A)  $(-\infty; +\infty)$ ;      B)  $[-1; +\infty)$ ;      C)  $(-\infty; -2] \cup [0; +\infty)$ ;  
 D)  $[0; +\infty]$       E)  $[2; +\infty)$ .

15\*.  $y = \frac{x}{x-1}$  funksiyaning qiymatlar to'plamini toping.

- A)  $(-\infty; 1) \cup (1; +\infty)$ ;      B)  $(-\infty; 0) \cup (0; 1) \cup (1; +\infty)$ ;  
 C)  $(-\infty; 1)$ ;      D)  $(1; +\infty)$ ;      E)  $(-\infty; +\infty)$ .

16\*.  $y = x + \frac{1}{x}$  funksiyaning qiymatlar to'plamini toping.

- A)  $(-\infty; 0) \cup (0; +\infty)$ ;      B)  $[1; +\infty)$ ;      C)  $(-\infty; 1)$ ;  
 D)  $(-\infty; -2] \cup [2; +\infty)$ ;      E)  $[2; +\infty)$ .

17\*.  $y = \sqrt{2x^2 + 12x + 7}$  funksiyaning qiymatlar to'plamini toping.

- A)  $(-\infty; +\infty)$ ;      B)  $[0; +\infty)$ ;      C)  $[\sqrt{7}; +\infty)$ ;  
 D)  $[\sqrt{11}; +\infty)$ ;      E)  $[2; +\infty)$ .

18\*.  $y = |2x-4| + |6+3x|$  funksiyaning qiymatlar to'plamini ko'rsating.

- A)  $[4; 6]$ ;      B)  $(-\infty; +\infty)$ ;      C)  $[0; +\infty)$ ;      D)  $[2; +\infty)$ ;      E)  $[8; +\infty)$ .

19\*.  $y = \frac{x-3}{x-3} + 4$  funksiyaning qiymatlar to'plamini toping.

- A)  $[3; 5]$ ;      B)  $(3; 5)$ ;      C)  $\{3; 5\}$ ;      D)  $[3; 5)$ ;      E)  $(3; 5]$ .

20\*.  $f(x) = |x+1| + |x-2|$  funksiyaning qiymatlar to'plamini toping.

- A)  $[3; +\infty)$ ;                      B)  $(3; +\infty)$ ;                      C)  $[0; +\infty)$ ;  
 D)  $[1; +\infty)$ ;                      E)  $[-1; +\infty)$ .

21. Quyidagi funksiyalardan qaysi biri juft?

- A)  $f(x) = \frac{10x^2}{x-1}$ ;                      B)  $f(x) = \frac{10x^2}{x^2-9}$ ;                      C)  $f(x) = x|x-1|$ ;  
 D)  $f(x) = x^2 + x^3$ ;                      E)  $f(x) = x + \frac{1}{x^2}$ .

22. Quyidagi funksiyalardan qaysi biri toq?

- A)  $f(x) = \frac{1}{x + \frac{1}{x+1}}$ ;                      B)  $f(x) = x^2 + \frac{1}{x^4}$ ;                      C)  $f(x) = \frac{3x}{3x+3}$ ;  
 D)  $f(x) = 1 + \frac{1}{x}$ ;                      E)  $f(x) = x^3 + \frac{1}{x^3} + 3$ .

23. Quyidagi funksiyalardan qaysi biri juft?

- A)  $f(x) = \frac{1}{\sqrt{x} + \frac{1}{\sqrt{x}}}$ ;                      B)  $f(x) = \frac{2x-4}{x^2+2x}$ ;  
 C)  $f(x) = x^3 + x^5 - x^7$ ;                      D)  $f(x) = |x+1| - x$ ;  
 E)  $f(x) = \frac{1}{x^2 + \frac{1}{x^2}}$ .

24. Quyidagi funksiyalardan qaysi biri juft?

- A)  $f(x) = \sqrt[3]{x^3 - x^5}$ ;                      B)  $f(x) = \sqrt{\frac{x^2+1}{x}}$ ;                      C)  $f(x) = \sqrt[4]{x}$ ;  
 D)  $f(x) = \frac{x}{x^4}$ ;                      E)  $f(x) = \frac{2x^2}{x^2+x+1}$ .

25.  $y = \sqrt[3]{x^3} + \sqrt[3]{x^5} + x$  funksiya uchun quyidagi xossalardan qaysi biri o'rinli?

- A) toq;                      B) juft;                      C) davriy;  
 D) toq ham emas, juft ham emas;                      E) toq va davriy.

26.  $y = \sqrt{x^2} + \sqrt{x^2}$  funksiya uchun quyidagi xossalardan qaysi biri to'g'ri?

- A) toq;                      B) juft;                      C) davriy;  
 D) toq ham emas, juft ham emas;                      E) toq va davriy.

27.  $f(x) = \sqrt{1+x+x^2} + \sqrt{1-x+x^2}$  funksiya uchun quyidagi xossalardan qaysi biri to'g'ri?

- A) juft ham emas, toq ham emas; B) toq;  
C) davriy; D) juft; E)  $[0; +\infty)$  oraliqda aniqlangan.

28. Quyidagi funksiyalardan qaysilari  $(2; +\infty)$  oraliqda o'sadi?

1.  $y = \frac{4}{2-x}$ ; 2.  $y = \frac{4x+31}{x+7}$ ; 3.  $y = 0,5x^2 - 2\sqrt{x}$ .

- A) 1; 3; B) faqat 1; C) 2; 3; D) faqat 3; E) hammasi.

29. Quyidagi funksiyalardan qaysilari  $[2; +\infty)$  oraliqda kamayadi?

1.  $y = 12x - x^3$ ; 2.  $y = \sqrt{x} - 2x^2$ ; 3.  $y = 0,5x^2 - 2\sqrt{x}$ .

- A) 1; 2; B) faqat 1; C) faqat 2;  
D) faqat 3; E) hammasi.

30. Quyidagi funksiyalardan qaysilari  $(-\infty; 0)$  oraliqda o'suvchi bo'ladi?

A)  $y = \frac{5}{x}$ ; B)  $y = 6 - 3x$ ; C)  $y = 3x + 2$ ;

D)  $y = x^4$ ; E)  $y = \sqrt{-x}$ .

31.  $y = \frac{x^3+2x^2-9x-18}{\sqrt{x^2-6x+9}+\sqrt{x-5}}$  funksiyaning nollarini toping.

- A) -2; B) 0; C) -3; -2; 3; D) 5; E) 3.

32.  $y = \frac{\sqrt{5x-1}-\sqrt{x^2+3}}{\sqrt{x+3}+\sqrt{x-2}}$  funksiya nollarining o'rta arifmetigini

toping.

- A) 1; B) 2; C) 2,5; D) 3; E) 4.

33\*.  $f\left(\frac{ax-b}{bx-a}\right) = x^{100} + x^{99} + x^{98} + \dots + x^2 + x + 2$  ( $|a| \neq |b|$ )

bo'lsa,  $f(1)$  ni hisoblang.

- A) 1; B) -1; C) 2; D) 101; E) 10.

34.  $y = x^2 - 2$  va  $y = |x|$  funksiyalarning kesishish nuqtalari koordinatalarini toping.

- A) (-2; 2), (2; 2); B) (2; 2); C) (-2; 2);  
D) (-1; 2); E) (-1; 2), (-2; 1).

35.  $y = \frac{2}{x+2}$  funksiya grafiqi qaysi choraklarda yotadi?

- A) I va II; B) I va III; C) II va IV;  
D) I, III va IV; E) I, II, va III.



36.  $f(x) = \sqrt{4 - 2x - 2x^2}$  funksiyaning eng katta qiymatini toping.  
 A)  $2\sqrt{2}$ ; B)  $\sqrt{3,5}$ ; C) 2; D)  $\sqrt{4,5}$ ; E) 0.
37. Agar  $f(x) = x^2$  va  $\varphi(x) = 2x - 1$  bo'lsa,  $x$  ning nechta qiymatida  $f(\varphi(x)) = \varphi(f(x))$  tenglik o'rinli bo'ladi?  
 A) 1; B) 2; C) 3; D) 4; E) J.
38.  $y = \sqrt[10]{x}$  funksiya uchun quyidagi mulohazalardan qaysi biri noto'g'ri?  
 A) juft funksiya;  
 B) grafigi (1024; 2) nuqtadan o'tadi;  
 C) aniqlanish sohasida o'sadi;  
 D) grafigi I chorakda joylashgan;  
 E) funksiya  $[0; +\infty)$  oraliqda aniqlangan.
39. Argumentning qanday qiymatlarida  $y = \frac{1}{x^2 - x - 1}$  funksiya qiymati (-1) ga teng bo'ladi?  
 A) 0; 1; B) -1; 0; 1; C) yo'1; D) 2; E) hech qanday qiymatida.
40. Agar  $A\left(\frac{1}{5}; \frac{24}{5}\right)$  nuqta teskari proporsionallikni ifodalovchi funksiyaga tegishli bo'lsa, shu funksiyani ko'rsating.  
 A)  $y = \frac{0,96}{x}$ ; B)  $y = \frac{1,92}{x}$ ; C)  $y = \frac{1}{3x}$ ; D)  $y = \frac{24}{x}$ ;  
 E)  $y = \frac{1}{24x}$ .
- 41\*.  $m$  ning qanday qiymatlarida  $y = 2mx + 1$  va  $y = (m - 6)x^2 - 2$  funksiyalarning graflari kesishmaydi?  
 A) (-3; 6); B) (-6; 3); C)  $(-\infty; -6) \cup (3; +\infty)$ ; D) (-6; 0); E)  $\emptyset$ .
42.  $y = \frac{x^2 - 4x - 5}{2x - 5}$  funksiya manfiy qiymatlarga ega bo'ladigan oraliqni ko'rsating.  
 A)  $(-\infty; 2,5)$ ; B) (2,5; 5); C)  $(-\infty; -1] \cup (2,5; 5]$ ;  
 D)  $(-\infty; -1)$ ; E)  $(-\infty; -1) \cup (2,5; 5)$ .
43.  $y = x^6$  va  $y = (2x - 10)^2$  funksiyalarning graflari nechta umumiy nuqtaga ega?  
 A) 1; B) 2; C) 3; D) 4; E) umumiy nuqtaga ega emas.
44.  $y = 2x + 1$  va  $y = -2 - x$  funksiyalar graflari koordinatalar tekisligining qaysi choragida kesishadi?

A) IV; B) III; C) II; D) I; E) kesishmaydi.

45. Agar  $f(x) = x^3 + 2x^2$  bo'lsa,  $f(x-1)$  ni toping.

A)  $x^3 + 5x^2 - x + 3$ ; B)  $x^3 - 2x^2 + 5x$ ; C)  $x^3 - x^2 - x + 1$ ;  
D)  $x^3 - 5x^2 + x - 1$ ; E)  $x^3 + x^2 + x + 1$ .

46.  $f(x) = \sqrt{x+2}(x^2 - 3x + \sqrt{2})$  funksiya grafigining  $Oy$  o'qi bilan kesishish nuqtasi ordinasini toping.

A)  $\sqrt{2}$ ; B)  $-\sqrt{2}$ ; C) 1; D) -2; E) 2.

47. Argumentning qanday qiymatlarida  $y = \frac{x^2 - x + 5}{x-1}$  funksiyaning qiymatlari (-5) dan kichik emas?

A) hech qanday qiymatida; B)  $[-4; 0)$ ; C)  $(1; +\infty)$ ;  
D)  $(-\infty; 0) \cup (0; 4) \cup (4; +\infty)$ ; E)  $[-4; 0] \cup (1; +\infty)$ .

48. Argumentning qanday qiymatlarida  $y = \frac{\sqrt{1-x^2}}{2}$  funksiyaning qiymatlari 1.5 dan katta bo'lmaydi?

A)  $(-\infty; +\infty)$ ; B)  $(-\infty; 1)$ ; C)  $[1; 0]$ ;  
D)  $[-1; 1]$ ; E)  $[0; 1]$ .

49\*.  $y = \frac{5}{2x^2 - 12x + 3}$  funksiyaning eng katta qiymati nechaga teng?

A) 5; B) 3; C) -3; D)  $-\frac{1}{3}$ ; E)  $1\frac{2}{3}$ .

50. Argumentning qanday qiymatida  $f(x) = 2x^2 - 6x + 10$  funksiyaning qiymati 6 ga teng bo'ladi?

A) 2; B) 1; C) -4; D) 1 va 2; E) -1 va 2.

51. Agar  $f(-4) = 2$  va  $f(6) = -3$  bo'lsa, chiziqli funksiyaning toping.

A)  $f(x) = -\frac{1}{2}x + 3$ ; B)  $f(x) = -\frac{1}{2}x - 2$ ;

C)  $f(x) = -\frac{1}{2}x$ ; D)  $f(x) = \frac{1}{2}x$ ;

E)  $f(x) = \frac{1}{2}x - 3$ .

52.  $a$  va  $b$  ning qanday qiymatlarida  $ax + by = -6$  va  $2x - 2y = 4$  tenglamalar bilan berilgan to'g'ri chiziqlar ustma-ust tushadi?

A)  $a = -3, b = 3$ ; B)  $a = 3, b = 3$ ; C)  $a = 3, b = -3$ ;

D)  $a = 3, b = 2$ ; E)  $a = 4, b = -2$ .

53\*.  $k$  ning qanday qiymatlarida  $f(x) = \frac{(k-3)x^3 + 6}{4}$  funksiya grafigi  $Ox$  o'qiga parallel bo'ladi?

A) hech qanday qiymatida; B) -2; C) -1; D) 0; E) 3.

54.  $f(x) = \frac{ax+2}{bx-2}$  funksiya grafigi  $A(2; 4)$   $B(-4; \frac{2}{3})$  nuqtalardan o'tsa,  $a$  va  $b$  larning qiymatlarini toping.

- A)  $a = 2, b = -\frac{7}{4}$ ; B)  $a = 2, b = \frac{7}{4}$ ; C)  $a = -1, b = \frac{7}{4}$ ;  
 D)  $a = -2, b = -2$ ; E)  $a = 2, b = 2$ .

55. Agar  $f(x) = \frac{1-x}{1+x}$  bo'lsa,  $f(\frac{1}{x}) + f(x)$  ni toping.

- A)  $\frac{4x}{1-x^2}$ ; B)  $\frac{4x}{x^2-1}$ ; C)  $\frac{x^2+1}{x^2-1}$ ; D) 0; E)  $\frac{2(x^2+1)}{1-x^2}$ .

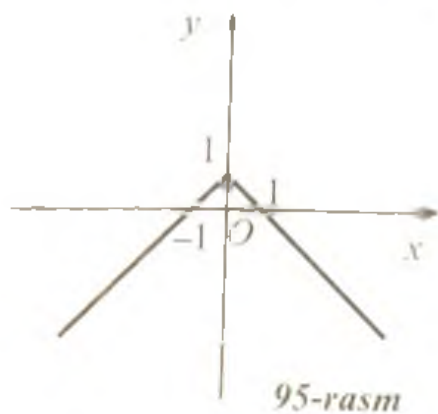

56. 95-rasmda qaysi funksiyaning grafigi tasvirlangan?

- A)  $y = -|x|$ ;  
 B)  $y = -|x| + 1$ ;  
 C)  $y = -|x| - 1$ ;  
 D)  $y = -|x - 1|$ ;  
 E)  $y = |x| + 1$ .

57. 96-rasmda qaysi funksiyaning grafigi tasvirlangan?

- A)  $y = |x + 2| + 2$ ;  
 B)  $y = -|x + 2| + 2$ ;  
 C)  $y = |x - 2| + 2$ ;  
 D)  $y = |x - 2| - 2$ ;  
 E)  $y = |x + 1| - 2$ .

58.  $y = 4x - 1$  funksiya teskari funksiyaning toping.

- A)  $y = (4x - 1)^{-1}$ ;  
 B)  $y = 1 - 4x$ ;  
 C)  $y = \frac{1}{4}x + \frac{1}{4}$ ;

- D)  $y = \frac{1}{4} - \frac{1}{4}x$ ; E)  $y = -\frac{1}{4}x - \frac{1}{4}$ .

59. Quyidagi funksiylardan qaysi biri  $y = \frac{2}{2x+1} - 2$  funksiya teskari funksiya?

- A)  $y = \frac{1}{x+2} - \frac{1}{2}$ ; B)  $y = -\frac{2x+1}{4x}$ ; C)  $y = \frac{2x+1}{2} - 2$ ;  
 D)  $y = -\frac{2}{2x+1} + 2$ ; E)  $y = \frac{1}{2} - \frac{1}{x+2}$ .

60.  $y = x^2 - 1$  funksiyaning  $x \in [0; +\infty)$  oraliqdagi teskari funksiyasini toping.

A)  $y = \frac{1}{x^2-1}$ ; B)  $y = \pm\sqrt{x+1}$ ; C)  $y = -\sqrt{x+1}$ ;

D)  $y = \sqrt{1-x}$ ; E)  $y = \sqrt{x+1}$ .

61.  $y = \frac{x+1}{2+3x}$  funksiyaning teskari funksiyasini toping.

A)  $y = \frac{2+3x}{x+1}$ ; B)  $y = \frac{2x-1}{1-3x}$ ; C)  $y = \frac{2x+1}{1-3x}$ ;

D)  $y = \frac{2x-1}{3x-1}$ ; E)  $y = \frac{2x+1}{3x+1}$ .

62.  $y = x^2 - 4x + 5$  funksiyaning  $[2; +\infty)$  oraliqdagi teskari funksiyasini toping.

A)  $y = 2 \pm \sqrt{x-1}$ ; B)  $y = 2 - \sqrt{x-1}$ ; C)  $y = 2 + \sqrt{1-x}$ ;

D)  $y = -x^2 + 4x - 5$ ; E)  $y = 2 + \sqrt{x-1}$ .

63.  $y = x^2 - 4x + 5$  funksiyaning  $(-\infty; 2]$  oraliqdagi teskari funksiyasini toping.

A)  $y = 2 - \sqrt{x-1}$ ; B)  $y = 2 \pm \sqrt{x-1}$ ; C)  $y = 2 + \sqrt{x-1}$ ;

D)  $y = -x^2 + 4x - 5$ ; E)  $y = 2 - \sqrt{1-x}$ .

64. Qaysi nuqta  $y = x^3 + 5x + 24$  funksiyaga teskari funksiya grafigiga tegishli?

A)  $(-2; 1)$ ; B)  $(0; -2)$ ; C)  $(4; 1)$ ; D)  $(-8; 1)$ ; E)  $(4; 5)$ .

65.  $y = 3x + 6$  funksiyaga teskari funksiya grafigi koordinatalar tekisligining qaysi choraklarida joylashgan?

A) I, III va IV;

B) III va IV;

C) II va IV;

D) I va III;

E) I, II va III.

## BIR O'ZGARUVCHILI KO'PHADLAR VA ULAR USTIDA AMALLAR

### 1-§. Ko'phad tushunchasi

Quyidagi ko'rinishdagi algebraik ifoda *bir o'zgaruvchili ko'phad* deb ataladi:

$$a_n x^n + a_{n-1} x^{n-1} + \dots + a_1 x + a_0 \quad (1)$$

Bu yerda  $a_i \in R$  ( $i = 0, n$ ) va ular ko'phadning *koeffitsiyentlari* deyiladi. Ko'phadni (1) ko'rinishda tasvirlanishi uning *standart shakli* yoki *kanonik yoyilmasi* deyiladi.  $a_0$  – *ozod had* deb ataladi.  $a_n \neq 0$  bo'lsa,  $a_n x^n$  had – ko'phadning *bosh hadi*,  $a_n$  – *bosh koeffitsiyent*,  $n$  esa ko'phadning *darajasi* deyiladi.

Quyidagi belgilashlarni kiritamiz:

$$P(x) = a_n x^n + a_{n-1} x^{n-1} + \dots + a_1 x + a_0$$

deg  $P(x)$  – ko'phadning darajasi.

Ta'rif.  $c$  – *hiror son bo'lsin*,  $P(x)$  ko'phadning  $x = c$  dagi qiymati deb

$$P(c) = a_n c^n + a_{n-1} c^{n-1} + \dots + a_1 c + a_0$$

ga teng songa aytiladi.

1-misol.  $P(x) = x^3 - 2x^2 + 3x + 5$  ko'phadning  $x = 2$  dagi qiymatini toping.

Yechilishi.  $P(2) = 2^3 - 2 \cdot 2^2 + 3 \cdot 2 + 5 = 11$ ;  $P(2) = 11$ .

Javob: 11.

Masalalar yechishda foydali bo'lgan, ko'phadning qiymatiga bog'liq ikkita oddiy tenglikni keltiramiz:

$$P(0) = a_0;$$

$$P(1) = a_n + a_{n-1} + \dots + a_1 + a_0$$

2-misol.  $(2x - 1)^{10} + (x^2 - 5x + 6)(x^3 - 3x^2 + 4x - 2)^{1981} + 4$  ko'phadni kanonik ko'rinishidagi koeffitsiyentlari yig'indisini toping.

Yechilishi. Berilgan ko'phadni  $P(x)$  bilan belgilaymiz. Faraz qilaylik,  $P(x)$  ko'phadni kanonik ko'rinishga keltirib, quyidagiga ega bo'laylik:

$$P(x) = a_n x^n + a_{n-1} x^{n-1} + \dots + a_1 x + a_0,$$

u holda,

$$P(1) = a_n + a_{n-1} + \dots + a_1 + a_0 = (2 \cdot 1 - 1)^{10} + (1^2 - 5 \cdot 1 + 6)(1^3 - 3 \cdot 1^2 + 4 \cdot 1 - 2)^{1981} + 4 = 1 + 2 \cdot 0 + 4 = 5.$$

Demak, koeffitsiyentlarning izlanayotgan yig'indisi 5 ga teng ekan.  
Javob: 5.

*Ta'rif.* Agar ikki  $P(x)$  va  $Q(x)$  ko'phadlar berilgan bo'lib, har bir  $c \in R$  son uchun  $P(c) = Q(c)$  tenglik bajarilsa, boshqacha aytganda, har bir  $x = c$  qiymatda  $P(x)$  va  $Q(x)$  ko'phadlarning qiymatlari ustma-ust tushsa, bu ko'phadlar teng deb ataladi.

Bu ta'rifdan quyidagi tasdiqning o'rinlilik kelib chiqadi. Ikki

$$P(x) = a_n x^n + a_{n-1} x^{n-1} + \dots + a_1 x + a_0 \text{ va}$$

$$Q(x) = b_m x^m + b_{m-1} x^{m-1} + \dots + b_1 x + b_0$$

ko'phad teng shu holda va faqat shu holda, qachonki

$$\begin{cases} n = m, \\ a_0 = b_0, \\ a_1 = b_1, \\ \dots \\ a_n = b_m \text{ bo'lsa.} \end{cases}$$

Bu tasdiqdan quyidagi natijaga kelamiz: ko'phadning kanonik ko'rinishi yagonadir.

## 2-§. Ko'phadlar ustida amallar

### 2.1. Ko'phadlarni qo'shish, ayirish va ko'paytirish.

$$P(x) = a_n x^n + a_{n-1} x^{n-1} + \dots + a_1 x + a_0,$$

$$Q(x) = b_m x^m + b_{m-1} x^{m-1} + \dots + b_1 x + b_0$$

ko'phadlar berilgan bo'lsin.

$P(x)$  va  $Q(x)$  ko'phadlarning yig'indisi, ayirmasi va ko'paytmasi quyidagi tengliklar bilan aniqlanadi:

$$P(x) + Q(x) = (a_n x^n + \dots + a_1 x + a_0) + (b_m x^m + \dots + b_1 x + b_0);$$

$$P(x) - Q(x) = (a_n x^n + \dots + a_1 x + a_0) - (b_m x^m + \dots + b_1 x + b_0);$$

$$P(x) \cdot Q(x) = (a_n x^n + \dots + a_1 x + a_0) \cdot (b_m x^m + \dots + b_1 x + b_0).$$

Bu yerda

$$1) \deg[P(x) + Q(x)] \leq \max\{\deg(P(x)); \deg(Q(x))\};$$

$$2) \deg[P(x) - Q(x)] \leq \max\{\deg(P(x)); \deg(Q(x))\};$$

$$3) \deg[P(x) \cdot Q(x)] \leq \deg(P(x)) + \deg(Q(x))$$

va  $P(x) \cdot Q(x)$  ko'phadning bosh koeffitsiyenti  $P(x)$  va  $Q(x)$  ko'phadlarning bosh koeffitsiyentlari ko'paytmasiga teng.

1-misol.  $P(x) = 2x^3 - 3x^2 + x + 4$ ,  $Q(x) = -2x^3 + 3x^2 + 2x + 1$  ko'phadlar yig'indisi, ayirmasi va ko'paytmasini toping.

Yechilishi.  $P(x) + Q(x) = 3x + 5;$

$$P(x) - Q(x) = 4x^3 - 6x^2 - x + 3;$$

$$P(x) \cdot Q(x) = -4x^6 + 12x^5 - 7x^4 - 9x^3 + 11x^2 + 9x + 4.$$

Ko'phadlarni qo'shish va ayirishni ularni ustma-ust yozib bajarish qulay. Bunda o'xshash hadlari bir ustunda joylashgan bo'lishi kerak. Hosil bo'lgan ko'phad  $P(x) \pm Q(x)$  ko'phadning kanonik tasvirini beradi.

2-misol.  $P(x) = x^5 + 3x^4 + 12x^3 + x^2 - x + 5$ ,  $Q(x) = 2x^3 + 7x^2 - 4$  ko'phadlar yig'indisi toping.

Yechilishi.

$$\begin{array}{r} x^5 + 3x^4 + 12x^3 + x^2 - x + 5 \\ + \phantom{x^5 + 3x^4 + } 2x^3 + 7x^2 - 4 \\ \hline x^5 + 3x^4 + 14x^3 + 8x^2 - x + 1 \end{array}$$

Javob:  $P(x) + Q(x) = x^5 + 3x^4 + 14x^3 + 8x^2 - x + 1.$

3-misol.  $P(x) = x^3 - x^2 + 3x + 5$ ,  $Q(x) = 2x^2 - 5x + 3$  ko'phadlar ko'paytmasini toping.

Yechilishi.

$$\begin{array}{r} x^3 - x^2 + 3x + 5 \\ \times 2x^2 - 5x + 3 \\ \hline 2x^5 - 2x^4 + 6x^3 + 10x^2 \\ + \phantom{2x^5 - 2x^4 + } - 5x^4 + 5x^3 - 15x^2 - 25x \\ \hline \phantom{2x^5 - 2x^4 + } 3x^3 - 3x^2 + 9x + 15 \\ \hline 2x^5 - 7x^4 + 14x^3 - 8x^2 - 16x + 15 \end{array}$$

Javob:  $P(x) \cdot Q(x) = 2x^5 - 7x^4 + 14x^3 - 8x^2 - 16x + 15.$

**2.2. Ko'phadni ko'phadga bo'lish.** Endi ko'phadlarni bo'lishni qarab chiqamiz. Ikki  $P(x)$  va  $Q(x)$  ko'phad berilgan bo'lsin, bunda  $Q(x) \neq 0$ .

Ta'rif. Agar shunday  $g(x)$  ko'phad mavjud bo'lib,  $P(x) = Q(x) \cdot g(x)$  tenglik bajarilsa, u holda  $P(x)$  ko'phad  $Q(x)$  ko'phadga bo'linadi, deyiladi.

$P(x)$  – bo‘linuvchi ko‘phad,  $Q(x)$  – bo‘luvchi ko‘phad,  $g(x)$  – bo‘linma ko‘phad deyiladi.

$$\begin{aligned} \text{Masalan, } x^3 - 1 &= (x - 1)(x^2 + x + 1), \\ x^3 + 1 &= (x + 1)(x^2 - x + 1), \\ x^2 - 1 &= (x + 1)(x - 1). \end{aligned}$$

Ko‘phadni ko‘phadga bo‘lishning bir necha usullari mavjud bo‘lib, biz ular bilan ushbu misollarni yechish jarayonida tanishib chiqamiz.

4-misol.  $P(x) = x^3 + 3x + 4$  ko‘phadni  $Q(x) = x + 1$  ko‘phadga bo‘ling.

Yechilishi. 1-usul.

$$x^3 + 3x + 4 = (x + 1) \cdot g(x).$$

$P(x)$  ko‘phad  $Q(x)$  ga bo‘linsa, yuqoridagi tenglik bajariladi. Ko‘phadlar ko‘paytmasining darajasi ko‘paytuvchilar daraja ko‘rsatkichlarining yig‘indisiga tengligini hisobga olsak,  $g(x)$  – ikkinchi darajali ko‘phad bo‘ladi. Bu ko‘phad  $g(x) = ax^2 + bx + c$  ko‘rinishda bo‘lsin. Bunda  $a, b, c$  – noaniq koeffitsiyentlardir. U holda

$$x^3 + 3x + 4 = (x + 1)(ax^2 + bx + c)$$

yoki

$$x^3 + 3x + 4 = ax^3 + (a + b)x^2 + (b + c)x + c.$$

Ikki ko‘phad tengligiga ko‘ra ularning bir xil darajalari oldidagi koeffitsiyentlarini tenglaymiz:

$$\begin{cases} a = 1 \\ a + b = 0 \\ b + c = 3 \\ c = 4 \end{cases} \Rightarrow \begin{cases} b = -1 \\ a = 1 \\ c = 4 \end{cases}$$

Demak,  $x^3 + 3x + 4 = (x + 1)(x^2 - x + 4)$ .

2-usul. «Burchak» usuli.

$$\begin{array}{r|l} x^3 + 3x + 4 & x + 1 \\ \underline{x^3 + x^2} & \underline{x^2 - x + 4} \\ -x^2 + 3x + 4 & \\ \underline{-x^2 - x} & \\ 4x + 4 & \\ \underline{4x + 4} & \\ 0 & \end{array}$$

Demak, bo‘linma  $g(x) = x^2 - x + 4$ .

Javob:  $x^2 - x + 4$ .



Biz koʻrgan misollarda koʻphad koʻphadga qoldiqsiz boʻlinadi. Bu hol har doim ham bajarilavermaydi.

### 2.3. Koʻphadni koʻphadga qoldiqli boʻlish.

Taʼrif.  $P(x)$  koʻphadni noldan farqli  $Q(x)$  koʻphadga qoldiqli boʻlish, bu shunday ikki  $g(x)$  va  $r(x)$  koʻphadlarni topishdan iboratki, bunda

$$P(x) = Q(x) \cdot g(x) + r(x)$$

tenglik bajariladi. Bu yerda  $\deg r(x) < \deg Q(x)$  yoki  $r(x) = 0$ .

5-misol.  $P(x) = 3x^5 - 2x^4 + 4x^2 - x + 11$  koʻphadni  $Q(x) = x^2 - x + 3$  koʻphadga boʻling.

Yechilishi.  $P(x) = Q(x) \cdot g(x) + r(x)$ ;

$\deg P(x) = 5$ ,  $\deg Q(x) = 2$ ,  $\deg g(x) = 3$ ,  $\deg r(x) = 1$ ;

$g(x) = ax^3 + bx^2 + cx + d$ ,  $r(x) = kx + m$ ;

$3x^5 - 2x^4 + 4x^2 - x + 11 = (x^2 - x + 3)(ax^3 + bx^2 + cx + d) + (kx + m)$ ;

$3x^5 - 2x^4 + 4x^2 - x + 11 = ax^5 + (b - a)x^4 + (3a + c - b)x^3 + (3b + d - c)x^2 + (3c + k - d)x + 3d + m$ .

Bir xil darajalar oldidagi koeffitsiyentlarni tenglaymiz:

$$\begin{cases} a = 3 \\ b - a = -2 \\ 3a + c - b = 0 \\ 3b + d - c = 4 \\ 3c + k - d = -1 \\ 3d + m = 11 \end{cases} \Rightarrow \begin{cases} a = 3, \\ b = -1, \\ c = -8, \\ d = -7, \\ k = 16, \\ m = 32. \end{cases}$$

Demak,  $3x^5 - 2x^4 + 4x^2 - x + 11 = (x^2 - x + 3)(3x^3 + x^2 - 8x - 7) + 16x + 32$ .

Javob:  $g(x) = 3x^3 + x^2 - 8x - 7$ ;  $r(x) = 16x + 32$ .

## 3-§. Koʻphadni ikkihadga boʻlish. Gerner sxemasi. Bezu teoremasi

### 3.1. Gerner sxemasi.

$$P(x) = a_n x^n + a_{n-1} x^{n-1} + \dots + a_1 x + a_0$$

koʻphadni  $Q(x) = x - \alpha$  ikkihadga boʻlishni koʻrib chiqaylik. Yuqoridagi bayon qilinganlarga asosan

$$P(x) = (x - \alpha)g(x) + r$$

tenglik oʻrinli. Bunda  $\deg g(x) = n - 1$ ,  $r$  - son.

$$g(x) = b_{n-1}x^{n-1} + b_{n-2}x^{n-2} + \dots + b_1x + b_0.$$

Noaniq koeffitsiyentlar usulini qo'llab,  $b_{n-1}, b_{n-2}, \dots, b_1, b_0$  va  $r$  sonlarni topamiz.

$$a_n x^n + a_{n-1} x^{n-1} + \dots + a_1 x + a_0 = (x - \alpha)(b_{n-1} x^{n-1} + b_{n-2} x^{n-2} + \dots + b_1 x + b_0) + r$$

tenglikning o'ng tomondagi qavslarni ochib, o'xshash hadlarni ixchamlangandan so'ng, quyidagilarni hosil qilamiz:

$$a_n x^n + a_{n-1} x^{n-1} + \dots + a_1 x + a_0 = b_{n-1} x^n + (b_{n-2} - \alpha b_{n-1}) x^{n-1} + (b_{n-3} - \alpha b_{n-2}) x^{n-2} + \dots + (b_0 - \alpha b_1) x + (r - \alpha b_0).$$

Ko'phadlarni tengligi ta'rifiga asosan quyidagi tengliklarga ega bo'lamiz:

$$\left\{ \begin{array}{l} a_n = b_{n-1}, \\ a_{n-1} = b_{n-2} - \alpha b_{n-1}, \\ a_{n-2} = b_{n-3} - \alpha b_{n-2}, \\ \dots \\ a_1 = b_0 - \alpha b_1, \\ a_0 = r - \alpha b_0; \end{array} \right. \quad \text{bundan} \quad \left\{ \begin{array}{l} b_{n-1} = a_n, \\ b_{n-2} = a_{n-1} + \alpha b_{n-1}, \\ b_{n-3} = a_{n-2} + \alpha b_{n-2}, \\ \dots \\ b_0 = a_1 + \alpha b_1, \\ r = a_0 + \alpha b_0. \end{array} \right.$$

Oxirgi sistemadan tartib bilan barcha  $b_{n-1}, b_{n-2}, \dots, b_1, b_0$  koeffitsiyentlarni va  $r$  qoldiqni hisoblab topish mumkin.

Hisoblashni Gornor sxemasi, deb ataladigan quyidagi jadval asosida bajarish qulaydir:

	$a_n$	$a_{n-1}$	$a_{n-2}$	...	$a_2$	$a_1$	$a_0$
$\alpha$	$b_{n-1} = a_n$	$b_{n-2} = a_{n-1} + \alpha b_{n-1}$	$b_{n-3} = a_{n-2} + \alpha b_{n-2}$	...	$b_1 = a_2 + \alpha b_2$	$b_0 = a_1 + \alpha b_1$	$r = a_0 + \alpha b_0$

Jadvalning birinchi qatoriga  $P(x)$  ko'phadning koeffitsiyentlari yoziladi (nolga tenglari ham), ikkinchi qatorga esa bo'linmaning mos koeffitsiyentlari va qoldiq yoziladi. Shuningdek, bu qatorning boshiga  $\alpha$  ning qiymati ham yoziladi.

Bu jadvaldagi bo'linma va qoldiq koeffitsiyentlari quyidagicha aniqlanadi: birinchi koeffitsiyent uchun birinchi qatordagi birinchi koeffitsiyent olinadi. Shundan so'ng har bir yangi koeffitsiyent chapda turgan sonni  $\alpha$  ga ko'paytirib, hosil bo'lgan ko'paytmaga yuqorida turgan sonni qo'shib hosil qilinadi.

1-misol.  $P(x) = 2x^5 - x^4 - 3x^3 + x - 3$  ko'phadni  $Q(x) = x - 1$  ko'phadga bo'lishda hosil bo'ladigan bo'linma va qoldiqni toping.

Biz ko'rgan misollarda ko'phad ko'phadga qoldiqsiz bo'linadi. Bu hol har doim ham bajarilavermaydi.

### 2.3. Ko'phadni ko'phadga qoldiqli bo'lish.

Ta'rif.  $P(x)$  ko'phadni noldan farqli  $Q(x)$  ko'phadga qoldiqli bo'lish, bu shunday ikki  $g(x)$  va  $r(x)$  ko'phadlarni topishdan iboratki, bunda

$$P(x) = Q(x) \cdot g(x) + r(x)$$

tenglik bajariladi. Bu yerda  $\deg r(x) < \deg Q(x)$  yoki  $r(x) = 0$ .

5-misol.  $P(x) = 3x^5 - 2x^4 + 4x^2 - x + 11$  ko'phadni  $Q(x) = x^2 - x + 3$  ko'phadga bo'ling.

Yechilishi.  $P(x) = Q(x) \cdot g(x) + r(x)$ ;

$\deg P(x) = 5$ ,  $\deg Q(x) = 2$ ,  $\deg g(x) = 3$ ,  $\deg r(x) = 1$ ;

$g(x) = ax^3 + bx^2 + cx + d$ ,  $r(x) = kx + m$ ;

$3x^5 - 2x^4 + 4x^2 - x + 11 = (x^2 - x + 3)(ax^3 + bx^2 + cx + d) + (kx + m)$ ;

$3x^5 - 2x^4 + 4x^2 - x + 11 = ax^5 + (b-a)x^4 + (3a+c-b)x^3 + (3b+d-c)x^2 + (3c+k-d)x + 3d+m$ .

Bir xil darajalar oldidagi koeffitsiyentlarni tenglaymiz:

$$\begin{cases} a = 3 \\ b - a = -2 \\ 3a + c - b = 0 \\ 3b + d - c = 4 \\ 3c + k - d = -1 \\ 3d + m = 11 \end{cases} \Rightarrow \begin{cases} a = 3, \\ b = -1, \\ c = -8, \\ d = -7, \\ k = 16, \\ m = 32. \end{cases}$$

Demak,  $3x^5 - 2x^4 + 4x^2 - x + 11 = (x^2 - x + 3)(3x^3 + x^2 - 8x - 7) + 16x + 32$ .

Javob:  $g(x) = 3x^3 + x^2 - 8x - 7$ ;  $r(x) = 16x + 32$ .

## 3-§. Ko'phadni ikkihadga bo'lish. Gorner sxemasi. Bez'u teoremasi

### 3.1. Gorner sxemasi.

$$P(x) = a_n x^n + a_{n-1} x^{n-1} + \dots + a_1 x + a_0$$

ko'phadni  $Q(x) = x - \alpha$  ikkihadga bo'lishni ko'rib chiqaylik. Yuqoridagi bayon qilinganlarga asosan

$$P(x) = (x - \alpha)g(x) + r$$

tenglik o'rinli. Bunda  $\deg g(x) = n - 1$ ,  $r$  - son.

$$g(x) = b_{n-1}x^{n-1} + b_{n-2}x^{n-2} + \dots + b_1x + b_0.$$

Noaniq koeffitsiyentlar usulini qo'llab,  $b_{n-1}, b_{n-2}, \dots, b_1, b_0$  va  $r$  sonlarni topamiz.

$$a_n x^n + a_{n-1} x^{n-1} + \dots + a_1 x + a_0 = (x - \alpha)(b_{n-1} x^{n-1} + b_{n-2} x^{n-2} + \dots + b_1 x + b_0) + r$$

tenglikning o'ng tomondagi qavslarni ochib, o'xshash hadlarni ixchamlangandan so'ng, quyidagilarni hosil qilamiz:

$$a_n x^n + a_{n-1} x^{n-1} + \dots + a_1 x + a_0 = b_{n-1} x^n + (b_{n-2} - \alpha b_{n-1}) x^{n-1} + (b_{n-3} - \alpha b_{n-2}) x^{n-2} + \dots + (b_0 - \alpha b_1) x + (r - \alpha b_0).$$

Ko'phadlarni tengligi ta'rifiga asosan quyidagi tengliklarga ega bo'lamiz:

$$\left\{ \begin{array}{l} a_n = b_{n-1}, \\ a_{n-1} = b_{n-2} - \alpha b_{n-1}, \\ a_{n-2} = b_{n-3} - \alpha b_{n-2}, \\ \dots \\ a_1 = b_0 - \alpha b_1, \\ a_0 = r - \alpha b_0; \end{array} \right. \text{ bundan } \left\{ \begin{array}{l} b_{n-1} = a_n, \\ b_{n-2} = a_{n-1} + \alpha b_{n-1}, \\ b_{n-3} = a_{n-2} + \alpha b_{n-2}, \\ \dots \\ b_0 = a_1 + \alpha b_1, \\ r = a_0 + \alpha b_0. \end{array} \right.$$

Oxirgi sistemadan tartib bilan barcha  $b_{n-1}, b_{n-2}, \dots, b_1, b_0$  koeffitsiyentlarni va  $r$  qoldiqni hisoblab topish mumkin.

Hisoblashni Gornor sxemasi, deb ataladigan quyidagi jadval asosida bajarish qulaydir:

	$a_n$	$a_{n-1}$	$a_{n-2}$	...	$a_2$	$a_1$	$a_0$
$\alpha$	$b_{n-1} = a_n$	$b_{n-2} = a_{n-1} + \alpha b_{n-1}$	$b_{n-3} = a_{n-2} + \alpha b_{n-2}$	...	$b_2 = a_2 + \alpha b_2$	$b_0 = a_1 + \alpha b_1$	$r = a_0 + \alpha b_0$

Jadvalning birinchi qatoriga  $P(x)$  ko'phadning koeffitsiyentlari yoziladi (nolga tenglari ham), ikkinchi qatorga esa bo'linmaning mos koeffitsiyentlari va qoldiq yoziladi. Shuningdek, bu qatorning boshiga  $\alpha$  ning qiymati ham yoziladi.

Bu jadvaldagi bo'linma va qoldiq koeffitsiyentlari quyidagicha aniqlanadi: birinchi koeffitsiyent uchun birinchi qatordagi birinchi koeffitsiyent olinadi. Shundan so'ng har bir yangi koeffitsiyent chapda turgan sonni  $\alpha$  ga ko'paytirib, hosil bo'lgan ko'paytmaga yuqorida turgan sonni qo'shib hosil qilinadi.

1-misol.  $P(x) = 2x^5 - x^4 - 3x^3 + x - 3$  ko'phadni  $Q(x) = x - 1$  ko'phadga bo'lishda hosil bo'ladigan bo'linma va qoldiqni toping.

Yechilishi. Koeffitsiyentlarni Gornier sxemasiga ko'ra topamiz.  $P(x)$  ko'phadning koeffitsiyentlarini jadvalni birinchi qatoriga yuqorida ko'rsatilgan qoida bo'yicha yozamiz:

	2	-1	-3	0	1	-3
1	2	$1 \cdot 2 - 1 = 1$	$1 \cdot 1 - 3 = -2$	$-2 \cdot 1 + 0 = -2$	$-2 \cdot 1 + 1 = -1$	$-1 \cdot 1 - 3 = -4$

Javob:  $g(x) = 2x^4 + x^3 - 2x^2 - 2x - 1$ ;  $r = -4$ .

**3.2. Bezu teoremasi.** Ko'phadni ikkihadga bo'lishdan hosil bo'ladigan  $r$  qoldiqni Bezu teoremasiga ko'ra topish mumkin bo'lib, bu teorema ko'phadlar nazariyasida asosiy teoremalardan biri bo'lib hisoblanadi va turli xarakterdagi masalalarni yechishda foydalaniladi.

Bezu teoremasi.  $P(x)$  ko'phadni  $(x - \alpha)$  ikkihadga bo'lishdagi qoldiq  $P(x)$  ko'phadning  $x = \alpha$  dagi qiymatiga teng, ya'ni  $r = P(\alpha)$ .

Teoremadan quyidagi natijalar kelib chiqadi.

1-natija.  $P(x)$  ko'phadning  $(x - \alpha)$  ikkihadga qoldiqsiz bo'linishi uchun  $x = \alpha$  da  $P(x)$  ko'phadning qiymati nolga teng bo'lishi zarur va yetarlidir, ya'ni  $P(\alpha) = 0$ .

2-natija.  $P(x) = x^n - a^n$  ko'phad  $n$  ning ixtiyoriy natural qiymatida  $(x - \alpha)$  ikkihadga qoldiqsiz bo'linadi.

3-natija.  $P(x) = x^n + \alpha^n$  ko'phad  $n$  ning ixtiyoriy toq qiymatida  $(x + \alpha)$  ikkihadga qoldiqsiz bo'linadi.

4-natija.  $P(x) = x^n - \alpha^n$  ko'phad  $n$  ning ixtiyoriy juft qiymatida  $(x + \alpha)$  ikkihadga qoldiqsiz bo'linadi.

2-misol.  $P(x) = x^3 + 2x^2 + 3x - 22$  ko'phadning  $Q(x) = x - 2$  ko'phadga qoldiqsiz bo'linishini isbotlang.

Yechilishi. Bizga  $P(2) = 0$  bo'lishini tekshirish yetarlidir.  $P(2) = 2^3 + 2 \cdot 2^2 + 3 \cdot 2 - 22 = 0$ . Demak,  $P(x)$  ko'phad  $Q(x)$  ko'phadga qoldiqsiz bo'linadi.

3-misol.  $2^{36} + 1$  ning 17 ga qoldiqsiz bo'linishini isbotlang.

Yechilishi.  $P(x) = x^9 + 1$  ko'phadni qarab chiqamiz. 3-natijaga ko'ra  $P(x) = x^9 + 1$  ko'phad  $(x + 1)$  ikkihadga qoldiqsiz bo'linadi. Bu misolda  $x = 2^4$  deb qarash mumkin.

$P(2^4) = (2^4)^9 + 1$ ; u holda  $x + 1 = 2^4 + 1 = 17$ .

Demak,  $2^{36} + 1$  soni 17 ga qoldiqsiz bo'linadi.

#### 4- §. Ko'phadning ildizlari

Ta'rif.  $P(\alpha) = 0$  bo'lsa,  $\alpha$  son  $P(x)$  ko'phadning ildizi deyiladi.

Teorema.  $P(x)$  ko'phad  $(x - \alpha)$  ikkihadga bo'linganda va faqat shu holda  $\alpha$  son  $P(x)$  ko'phadning ildizi bo'ladi.

Butun koeffitsiyentli ko'phadning butun va ratsional ildizlarini topish muhim ahamiyatga ega.

Teorema. Agar  $\alpha$  soni butun koeffitsiyentli  $P(x) = a_n x^n + a_{n-1} x^{n-1} + \dots + a_1 x + a_0$  ( $a_i \in Z$ ) ko'phadning butun ildizi bo'lsa, u holda  $\alpha$  son  $a_0$  ozod hadning bo'luvchisidir.

Natija. Butun koeffitsiyentli ko'phadning butun ildizlari ozod hadning bo'luvchilaridan iborat bo'ladi.

Bu natijani hamda Bezu teoremasi va Gerner sxemasini tatbiq etish butun koeffitsiyentli ko'phadning barcha butun ildizlarini topish imkonini beradi.

1-misol.  $P(x) = x^4 - 4x^3 - 13x^2 + 28x + 12$  ko'phadning barcha butun ildizlarini toping.

Yechilishi.  $P(x)$  ko'phadning butun ildizlari ozod had 12 ning bo'luvchilaridan iborat bo'lishi kerak, ya'ni quyidagi  $\{\pm 1; \pm 2; \pm 3; \pm 4; \pm 6; \pm 12\}$  sonlar ko'phadning ildizlari bo'lishi mumkin.

Gerner sxemasi va Bezu teoremasini qo'llab quyidagi jadvalni hosil qilamiz:

	1	-4	-13	28	12
-1	1	-5	-8	36	-24 = P(-1)
1	1	-3	-16	12	24 = P(1)
-2	1	-6	-1	30	-48 = P(-2)
2	1	-2	-17	-6	0 = P(2)

$P(2) = 0$  bo'lganligi uchun  $x = 2$  berilgan  $P(x)$  ko'phadning ildizi bo'ladi:

$$P(x) = (x - 2)(x^3 - 2x^2 - 17x - 6).$$

$P(x)$  ko'phadning boshqa ildizlarini topish uchun  $g(x) = x^3 - 2x^2 - 17x - 6$  ildizlarini izlash yetarlidir. Bu ko'phadning ildizlari (-6) ning bo'luvchilari  $\{\pm 1; \pm 2; \pm 3; \pm 6\}$  orasida bo'ladi. -1; 1 va -2 sonlari  $P(x)$  ko'phadning ildizlari bo'la olmaganidan ular  $g(x)$  ko'phadning ham ildizlari bo'la olmasligini ta'kidlab o'tamiz. Shuni e'tiborga olib, ushbu jadvalga ega bo'lamiz:

	1	-2	-17	-6
2	1	0	-17	-40 = $P_1(2)$
-3	1	-5	-2	0 = $P_1(-3)$

$x = -3$  soni  $g(x)$  ko'phadning ildizi ekan, demak, u  $P(x)$  ko'phadning ham ildizidir. Shu sababli

$$P(x) = (x - 2)(x + 3)(x^2 - 5x - 2).$$

bu yerda  $x^2 - 5x - 2$  kvadrat uchhad butun ildizlarga ega emas.

Shunday qilib,  $P(x)$  ko'phad ikkita butun ildizga ega ekan:  $x_1 = 2$  va  $x_2 = -3$ .

Javob: -3; 2.

**Ta'rif.** Agar  $P(x)$  ko'phad  $(x - \alpha)^k$  ( $k \in \mathbb{N}$ ,  $k > 1$ ) ga qoldiqsiz bo'linsa, lekin  $(x - \alpha)^{k+1}$  ga qoldiqsiz bo'linmasa, u holda  $\alpha$  son ko'phadning  $k$ -karrali ildizi deyiladi.

Endi butun koeflitsiyentli ko'phadning ratsional ildizlarini topishni qarab chiqamiz.

**Teorema.** Agar  $P(x) = x^n + a_{n-1}x^{n-1} + \dots + a_1x + a_0$  bosh koeflitsiyenti birga teng bo'lgan butun koeflitsiyentli ko'phad bo'lib, ratsional ildizga ega bo'lsa, u holda bu ildiz butun sonidir.

**Natija.** Agar bosh koeflitsiyenti birga teng bo'lgan ko'phadning barcha koeflitsiyentlari butun sonlar bo'lsa, u holda bu ko'phadning barcha ratsional ildizlari butun sonlardir.

Endi  $a_n \neq 1$  bo'lgan holni qarab chiqamiz.

**Teorema.** Agar  $P(x) = a_n x^n + a_{n-1} x^{n-1} + \dots + a_1 x + a_0$  butun koeflitsiyentli ko'phad  $\alpha = \frac{p}{q}$  ( $p$  va  $q$  o'zaro tub sonlar) ratsional ildizga ega bo'lsa, u holda  $p$  - ozod had  $a_0$  ning bo'luvchilari,  $q$  esa bosh koeflitsiyent  $a_n$  ning musbat bo'luvchilari bo'ladi.

2-misol.  $P(x) = 2x^3 + 3x^2 + 6x - 4$  ko'phadning ratsional ildizlarini toping.

**Yechilishi.** Ozod hadning bo'luvchilari quyidagi sonlardan iborat bo'ladi:  $\{\pm 1; \pm 2; \pm 4\}$ . Bosh koeflitsiyentning musbat bo'luvchilari:  $\{1; 2\}$ . Demak, ko'phadning ratsional ildizlari quyidagi sonlar ichida bo'ladi:  $\{\pm 1; \pm 2; \pm 4; \pm \frac{1}{2}\}$ .

Bu sonlarning qaysi biri berilgan tenglamaning ildizi ekanligini Gornor sxemasidan foydalanib tekshiramiz. Tekshirish natijasi ushbu jadvalda keltirilgan:

	2	3	6	-4
$-\frac{1}{2}$	2	2	5	$-\frac{13}{2} = P\left(-\frac{1}{2}\right)$
$\frac{1}{2}$	2	4	8	$0 = P\left(\frac{1}{2}\right)$

Demak,  $\frac{1}{2}$  soni berilgan tenglama ildizi ekan. Shu sababli,

$$P(x) = 2x^3 + 3x^2 + 6x - 4 = \left(x - \frac{1}{2}\right)(2x^2 + 2x + 8).$$

Bu yerda  $2x^2 + 2x + 8$  kvadrat uchhad haqiqiy ildizlarga ega emas.

Javob:  $\frac{1}{2}$ .

Berilgan  $P(x) = a_n x^n + a_{n-1} x^{n-1} + \dots + a_1 x + a_0$  ko'phadning  $\alpha$  ratsional ildizlarini topishni

$$T(y) = y^n + a_{n-1} y^{n-1} + a_{n-2} y^{n-2} + \dots + a_0 a_n^{n-1}$$

ko'phadni ildizlarini topishga keltirish mumkin. Bunda  $y = a_n x$ .

3-misol.  $P(x) = 12x^3 - 4x^2 - 3x + 1$  ko'phadning ildizlarini toping.

$$\begin{aligned} \text{Yechilishi. } Q(x) &= 12^3 P(x) = 12^3 x^3 - 4 \cdot 12^2 x^2 - 3 \cdot 12^2 x + 12^2 = \\ &= (12x)^3 - 4(12x)^2 - 36(12x) + 144 \end{aligned}$$

ko'phadni ko'rib chiqaylik va bunda  $y = 12x$  bo'lsin, u holda

$$T(y) = y^3 - 4y^2 - 36y + 144$$

ko'phadni hosil qilamiz va  $T(y)$  ko'phadni ildizlarini izlaymiz. 144 ning bo'luvchilari:  $\{\pm 1; \pm 2; \pm 3; \pm 4; \pm 6; \pm 8; \pm 9; \pm 12; \pm 18; \pm 24; \pm 36; \pm 48; \pm 72; \pm 144\}$ . Gerner sxemasini qo'llab topamiz:

	1	-4	-36	144
4	1	0	-36	$0 = P(4)$

Shunday qilib,  $T(y) = (y - 4)(y^2 - 36) = (y - 4)(y - 6)(y + 6)$ .

Demak,  $y_1 = 4$ ,  $y_2 = 6$ ,  $y_3 = -6$ .

$$y = 12x \text{ dan: } x_1 = \frac{1}{3}, x_2 = \frac{1}{2}, x_3 = -\frac{1}{2}.$$

Javob:  $\left\{-\frac{1}{2}; \frac{1}{3}; \frac{1}{2}\right\}$ .



## Mustaqil ishlash uchun test topshiriqlari

1. Agar quyidagi ayniyat bajarilsa, noma'lum  $a$ ,  $b$ ,  $c$  sonlarni

aniqlang: 
$$\frac{x+5}{(x-1)(x-2)(x-3)} = \frac{a}{x-1} + \frac{b}{x-2} + \frac{c}{x-3}$$

- A)  $a = 3; b = -7; c = 4$     B)  $a = 4; b = -7; c = 3$   
 C)  $a = -7; b = 3; c = 4$     D)  $a = 4; b = 3; c = -7$   
 E)  $a = 3; b = 7; c = 4$ .

2.  $1 + (x^2 - 6x + 5)(x^6 + 3x^4 - 2x^3 + x^2 - x - 7)^3 + (x^2 - 3x + 1)^{22}(x^2 + 3x + 7)$  ko'phadning standart ko'rinishidagi barcha koeffitsiyentlari yig'indisini toping.

- A) 12;    B) -12;    C) 11;    D) -11;    E) 10.

3\*.  $x^4 - ax^2 + 4x^2 - x + 1$  ko'phadni  $x - 2$  ga bo'lishdan chiqadigan qoldiq 7 ga teng bo'lsa,  $a$  ni toping.

- A) 6;    B) -6;    C) 7;    D) -7;    E) 8.

4\*.  $2^{64} - 1$  quyidagi sonlardan qaysi biriga qoldiqsiz bo'linadi?

- A) 15;    B) 16;    C) -15;    D) 13;    E) -13.

5.  $x^3 - x^2 - x + 1$  ko'phadni ko'paytuvchilarga ajrating.

- A)  $(x+1)(x-1)^2$ ;    B)  $(x+1)^2(x-1)$ ;  
 C)  $(x+1)x(x-1)$ ;    D)  $x(x+1)^2$ ;    E)  $x(x-1)^2$ .

6. Agar  $2x^3 - 8x^2 + 9x - 9 = (x-3)(2x^2 + ax + b)$  ga teng bo'lsa,  $a$  va  $b$  larni toping.

- A)  $a = -2; b = 3$ ;    B)  $a = 2; b = -3$ ;    C)  $a = 2; b = 3$ ;  
 D)  $a = -2; b = -3$ ;    E)  $a = 3; b = -2$ .

7\*. Agar  $P(x) = 2x^3 - 5x^2 + ax + b$  ko'phad  $Q(x) = x^2 - 4$  ko'phadga bo'linishi ma'lum bo'lsa,  $a$  va  $b$  larni toping.

- A)  $a = -8; b = 20$ ;    B)  $a = 8; b = 20$ ;    C)  $a = 8; b = -20$ ;  
 D)  $a = -8; b = -20$ ;    E)  $a = 20; b = 8$ .

8.  $x^4 + 5x^2 + 6 = 0$  tenglamani yeching.

- A)  $\emptyset$ ;    B) 2; 3;    C) 3; 2;    D) -3; -2;    E) -2; -3.

9.  $x^4 + 5x^2 + 6$  ko'phadni ko'paytuvchilarga ajrating.

- A)  $(x^2 + 3)(x^2 + 2)$ ;    B)  $(x^2 - 3)(x^2 - 2)$ ;    C)  $(x^2 + 3)(x + 2)(x + 1)$ ;  
 D)  $(x^2 + 3)(x - 2)(x - 1)$ ;    E)  $(x^2 - 3)(x + 2)(x + 1)$ .

10. Agar  $(x-1)^2(x+1)^3 + 3x - 1$  ifoda standart shakldagi ko'phad ko'rinishida yozilsa, uning koeffitsiyentlari yig'indisi nechaga teng bo'ladi?

- A) 10;    B) 2;    C) 4;    D) 3;    E) 1.

11.  $a$  va  $b$  ning qanday qiymatida  $x^2+x-6 = \frac{a}{x-2} + \frac{b}{x+3}$  tenglik ayniyat bo'ladi?

A)  $a = 1; b = 1$ ; B)  $a = \frac{2}{5}, b = -\frac{2}{5}$ ; C)  $a = 5; b = -5$ ;

D)  $a = \frac{2}{5}, b = \frac{2}{5}$ ; E)  $a = -\frac{1}{5}, b = \frac{2}{5}$ .

12.  $x^3 + 5x^2 - 4x - 20 = 0$  tenglamaning ildizlari ko'paytmasini toping.

A) -10; B) 20; C) -4; D) -20; E) 16.

13.  $(4x+1)\left(x-\frac{1}{4}\right) = 0$  bo'lsa,  $4x + 1$  qanday qiymatlar qabul qiladi?

A) faqat  $-\frac{1}{4}$ ; B) faqat  $\frac{1}{4}$ ; C) faqat 0;

D) 0 yoki 2; E)  $-\frac{1}{4}$  yoki  $\frac{1}{4}$ .

14.  $x^4 - 13x^2 + 36 = 0$  tenglamaning eng katta va eng kichik ildizlari ayirmasini toping.

A) 5; B) 1; C) 7; D) 0; E) 6.

15.  $x^4 + x^2 + 1$  ni ko'paytuvchilarga ajrating.

A)  $(x^2 + x + 1)(x^2 + x - 1)$ ;

B)  $(x^2 + x + 1)(x^2 - x + 1)$ ;

C)  $(x^2 + x + 1)(x^2 - x - 1)$ ;

D)  $(x^2 + x + 1)(-x^2 + x - 1)$ ;

E) ko'paytuvchilarga ajratib bo'lmaydi.

SONLI KETMA-KETLIKLAR. PROGRESSIYALAR

1-§. Chekli va cheksiz sonli ketma-ketliklar

Har bir natural son  $n = 1; 2; 3; \dots$  ga biror qonuniyat bilan  $a_n$  son mos keltirilsa, bu bilan  $a_1, a_2, a_3, \dots, a_n, \dots$  sonlar ketma-ketligi aniqlangan deyiladi.

Sonlarning quyidagi to'plamlarini qarab chiqaylik:

$$1, 2, 3, \dots, n, \dots \quad (1)$$

$$1, -\frac{1}{2}, \frac{1}{3}, -\frac{1}{4}, \dots, \frac{(-1)^{n-1}}{n}, \dots \quad (2)$$

$$\sin 1, \sin 2, \dots, \sin n, \dots \quad (3)$$

Bu to'plamlarning har biridagi istalgan son shu to'plamda tutgan o'rniga mos nomer bilan ta'minlangan, deb hisoblash tabiiy va aksincha, har qanday nomer ko'rsatilganda ham bu to'plamlarning har biridan shu nomerga ega bo'lgan son topiladi. Shunday qilib, yuqorida keltirilgan to'plamlarda har bir sonning aniq mos nomeri bor va u shu nomer bilan to'la aniqlanadi. Bu sonli to'plamlarni berish har bir natural son  $n$  ga (nomerga) bittagina son ( $n$  nomerli) to'g'ri keladigan moslikni berish, degan so'zdir.

Ta'rif. *Natural sonlar to'plamida aniqlangan sonli funksiya sonli cheksiz ketma-ketlik deyiladi (yoki natural sonlar to'plamini haqiqiy sonlar to'plamining qismiga akatlanishiga sonlar ketma-ketligi deyiladi).* Odatda bu sonli funksiya argumenti  $n$  bilan belgilanadi.

Ketma-ketlikning ayrim sonlari uning *hadlari* deyiladi va odatda quyidagicha belgilanadi:

$$a_1, a_2, a_3, \dots, a_n, \dots, \text{ yoki } \{a_n\}.$$

**1.1. Sonli ketma-ketlikning berilish usullari.** Sonli ketma-ketlikning berilish, agar bu ketma-ketlik biror hadi tutgan o'rnining nomeri ma'lum bo'lsa, uning shu hadi qanday topilishi degan so'zdir.

Sonli ketma-ketliklarni berishning turli xil usullari mavjud.

Ta'rif. *Ketma-ketlikning istalgan hadini shu hadining nomeri orqali ifodalaydigan formula ketma-ketlik umumiy hadining formulasi deyiladi.*

Yuqorida olingan misollarda ketma-ketliklarning umumiy hadlari mos ravishda

$$a_n = n, \quad (1')$$

$$a_n = \frac{(-1)^{n-1}}{n}, \quad (2')$$

$$a_n = \sin n \quad (3')$$

shaklda yozilgan.

Ta'rif. *Ketma-ketlikning biror hadidan boshlab ixtiyoriy hadini bir yoki bir nechta oldingi hadlari yordamida ifodalaydigan formula rekurrent formula deyiladi.*

1-misol.  $a_1 = 1, a_2 = 1$  va  $a_{n+2} = a_n + a_{n+1}, n \geq 1$  shartlari bilan berilgan ketma-ketlik hadlarini yozing.

Yechilishi:  $a_1 = 1, a_2 = 1, a_3 = 2, a_4 = 3, a_5 = 5, a_6 = 8, \dots$

Bu ketma-ketlikning hadlari *Fibonachchi sonlari* deb ataladi.

2-misol.  $1, 2, 6, 24, 120, \dots, n!, \dots$  ketma-ketlikni quyidagi rekurrent formula bilan yozish mumkin:

$$a_1 = 1, a_{n+1} = (n+1) \cdot a_n.$$

Shunday hollar ham bo'ladiki, ketma-ketlik o'z hadlarining ta'rifi bilan beriladi. Masalan,  $1,4; 1,41; 1,414$  ketma-ketlik  $\sqrt{2}$  sonining  $0,1; 0,01; 0,001$  gacha va hokazo aniqlikda kami bilan olingan taqribiy qiymatlaridan tuzilgan. Bunday hollarda, umuman aytganda, ba'zan umumiy had formulasini aniqlab bo'lmaydi, shunga qaramay ketma-ketlik to'la aniqlangan bo'ladi.

**1.2. Monoton ketma-ketliklar.** Ta'rif. *Hadlari soni chekli bo'lgan ketma-ketlik — chekli ketma-ketlik, hadlarining soni cheksiz bo'lgan ketma-ketlik cheksiz ketma-ketlik deyiladi.*

Ta'rif. *Agar ketma-ketlikning har bir keyingi hadi oldingi hadidan katta (kichik), ya'ni  $a_n < a_{n+1}$  ( $a_n > a_{n+1}$ ) bo'lsa, bu ketma-ketlik o'suvchi (kamayuvchi) ketma-ketlik deyiladi.*

3-misol.  $a_n = \frac{n+1}{3n-1}$  ketma-ketlikning kamayuvchiligini ko'rsating.

Yechilishi.

## SONLI KETMA-KETLIKLAR. PROGRESSIYALAR

### 1-§. Chekli va cheksiz sonli ketma-ketliklar

Har bir natural son  $n = 1; 2; 3; \dots$  ga biror qonuniyat bilan  $a_n$  son mos keltirilsa, bu bilan  $a_1, a_2, a_3, \dots, a_n, \dots$  sonlar ketma-ketligi aniqlangan deyiladi.

Sonlarning quyidagi to'plamlarini qarab chiqaylik:

$$1, 2, 3, \dots, n, \dots \quad (1)$$

$$1, -\frac{1}{2}, \frac{1}{3}, -\frac{1}{4}, \dots, \frac{(-1)^{n-1}}{n}, \dots \quad (2)$$

$$\sin 1, \sin 2, \dots, \sin n, \dots \quad (3)$$

Bu to'plamlarning har biridagi istalgan son shu to'plamda tutgan o'rniga mos nomer bilan ta'minlangan, deb hisoblash tabiiy va aksincha, har qanday nomer ko'rsatilganda ham bu to'plamlarning har biridan shu nomerga ega bo'lgan son topiladi. Shunday qilib, yuqorida keltirilgan to'plamlarda har bir sonning aniq mos nomeri bor va u shu nomer bilan to'la aniqlanadi. Bu sonli to'plamlarni berish har bir natural son  $n$  ga (nomerga) bittagina son ( $n$  nomerli) to'g'ri keladigan moslikni berish, degan so'zdir.

**Ta'rif.** *Natural sonlar to'plamida aniqlangan sonli funksiya sonli cheksiz ketma-ketlik deyiladi (yoki natural sonlar to'plamini haqiqiy sonlar to'plamining qismiga akslanishiga sonlar ketma-ketligi deyiladi).* Odatda bu sonli funksiya argumenti  $n$  bilan belgilanadi.

Ketma-ketlikning ayrim sonlari uning *hadlari* deyiladi va odatda quyidagicha belgilanadi:

$$a_1, a_2, a_3, \dots, a_n, \dots \text{ yoki } \{a_n\}.$$

**1.1. Sonli ketma-ketlikning berilish usullari.** Sonli ketma-ketlikning berish, agar bu ketma-ketlik biror hadi tutgan o'rnining nomeri ma'lum bo'lsa, uning shu hadi qanday topilishi degan so'zdir.

Sonli ketma-ketliklarni berishning turli xil usullari mavjud.

**Ta'rif.** *Ketma-ketlikning istalgan hadini shu hadining nomeri orqali ifodalaydigan formula ketma-ketlik umumiy hadining formulasi deyiladi.*

Yuqorida olingan misollarda ketma-ketliklarning umumiy hadlari mos ravishda

$$a_n = n, \quad (1')$$

$$a_n = \frac{(-1)^{n-1}}{n}, \quad (2')$$

$$a_n = \sin n \quad (3')$$

shaklda yozilgan.

**Ta'rif.** *Ketma-ketlikning biror hadidan boshlab ixtiyoriy hadini bir yoki bir nechta oldingi hadlari yordamida ifodalaydigan formula rekurrent formula deyiladi.*

1-misol.  $a_1 = 1, a_2 = 1$  va  $a_{n+2} = a_n + a_{n+1}, n \geq 1$  shartlari bilan berilgan ketma-ketlik hadlarini yozing.

Yechilishi:  $a_1 = 1, a_2 = 1, a_3 = 2, a_4 = 3, a_5 = 5, a_6 = 8, \dots$

Bu ketma-ketlikning hadlari *Fibonachchi sonlari* deb ataladi.

2-misol.  $1, 2, 6, 24, 120, \dots, n!, \dots$  ketma-ketlikni quyidagi rekurrent formula bilan yozish mumkin:

$$a_1 = 1, a_{n+1} = (n+1) \cdot a_n.$$

Shunday hollar ham bo'ladiki, ketma-ketlik o'z hadlarining ta'rifi bilan beriladi. Masalan,  $1,4; 1,41; 1,414$  ketma-ketlik  $\sqrt{2}$  sonining  $0,1; 0,01; 0,001$  gacha va hokazo aniqlikda kami bilan olingan taqribiy qiymatlaridan tuzilgan. Bunday hollarda, umuman aytganda, ba'zan umumiy had formulasini aniqlab bo'lmaydi, shunga qaramay ketma-ketlik to'la aniqlangan bo'ladi.

**1.2. Monoton ketma-ketliklar.** **Ta'rif.** *Hadlari soni chekli bo'lgan ketma-ketlik — chekli ketma-ketlik, hadlarining soni cheksiz bo'lgan ketma-ketlik cheksiz ketma-ketlik deyiladi.*

**Ta'rif.** *Agar ketma-ketlikning har bir keyingi hadi oldingi hadidan katta (kichik), ya'ni  $a_n < a_{n+1}$  ( $a_n > a_{n+1}$ ) bo'lsa, bu ketma-ketlik o'suvchi (kamayuvchi) ketma-ketlik deyiladi.*

3-misol.  $a_n = \frac{n+1}{3n-1}$  ketma-ketlikning kamayuvchiligini ko'rsating.

Yechilishi.

$$a_{n+1} - a_n = \frac{n+2}{3n+2} - \frac{n+1}{3n-1} = \frac{3n^2+6n-n-2-3n^2-3n-2n-2}{(3n+2)(3n-1)} =$$

$$= \frac{-4}{(3n+2)(3n-1)} < 0.$$

Demak,  $a_{n+1} < a_n$ , ya'ni  $\{a_n\}$  kamayuvchi ketma-ketlik ekan.

Ta'rif. Agar ketma-ketlikning barcha hadlari uchun  $a_{n+1} \geq a_n$  ( $a_{n+1} \leq a_n$ ) o'rinli bo'lsa, bunday ketma-ketlik kamaymaydigan (o'smaydigan) ketma-ketlik deyiladi.

O'smaydigan va kamaymaydigan ketma-ketliklar *monoton ketma-ketliklar* deyiladi.

Ta'rif. Agar  $\{a_n\}$  ketma-ketlikning hamma hadlari biror  $(a; b)$  oraliqda joylashsa, bu ketma-ketlik *chegaralangan ketma-ketlik* deyiladi.

Agar  $\{a_n\}$  ketma-ketlik chegaralangan bo'lsa, u holda *shunday*  $M$  musbat son mavjudki,  $|a_n| < M$  munosabat o'rinli bo'ladi.

Agar ketma-ketlik chegaralanmagan bo'lmasa, uni *chegaralanmagan ketma-ketlik* deyiladi.

Masalan, ushbu

$$\frac{1}{2} \cdot \frac{2}{3} \cdot \frac{3}{4} \cdot \dots \cdot \frac{n}{n+1} \cdot \dots$$

ketma-ketlikning barcha hadlari 1 dan kichik, ya'ni

$$a_n < 1.$$

1,4; 1,41; 1,414; 1,4142; ... ketma-ketlik esa  $\sqrt{2}$  sonining o'qli yaqinlashuvchilaridan iborat.  $1 < a_n < 2$  ekanligi ravshan, demak, bu ketma-ketlik chegaralangan.

**1.3. Ketma-ketlikning geometrik tasviri.** Ketma-ketlikni geometrik tasvirlashda ikki usuldan foydalaniladi.

1-usul.  $\{a_n\}$  ketma-ketlik funksiya bo'lgani uchun bu funksiyani uning grafigi yordamida, ya'ni koordinatalar tekisligining  $A_1(x; y)$  nuqtalari to'plami bilan tasvirlash mumkin. Ba'zi hollarda koordinata o'qlarida masshtablarini har xil qilib olish qulaylik beradi.

97-rasmda umumiy hadlari  $a_n = \frac{1}{n+1}$  va  $a_n = \frac{(-1)^n}{n+1}$  ( $n \in N$ ) formulalar bilan berilgan ketma-ketliklar tasvirlangan.

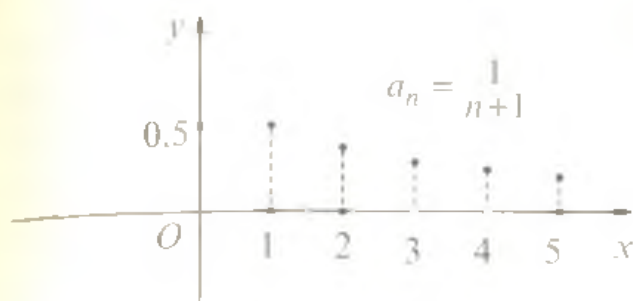

a)

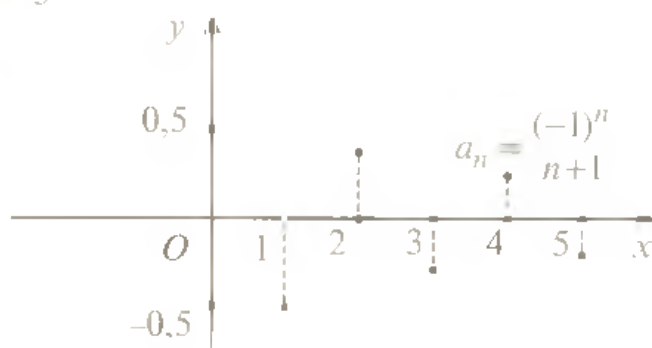

b)

97-rasm

2-usul. Ketma-ketlikning hadlari tegishli belgilar qo'yilgan koordinata to'g'ri chizig'ining nuqtalari bilan tasvirlanadi. 98-rasmda  $a_n = \frac{1}{n+1}$  va  $a_n = \frac{(-1)^n}{n+1}$  formulalar bilan berilgan ketma-ketliklar koordinata to'g'ri chizig'ida tasvirlangan.

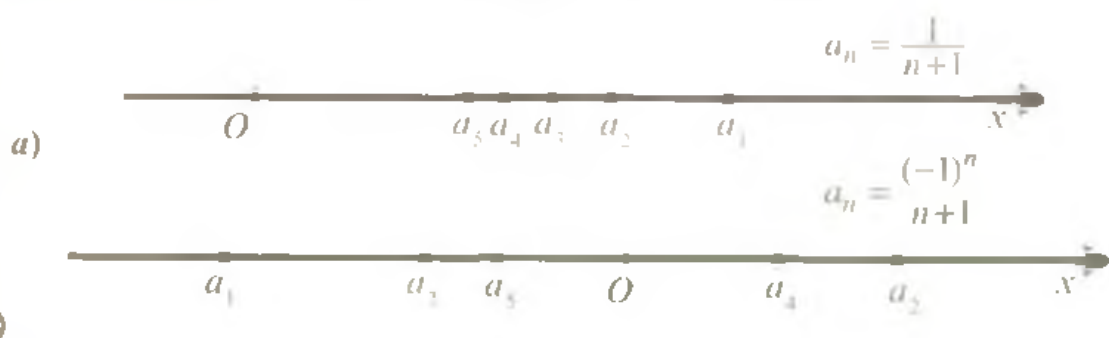

98-rasm

Tasvirlangan ikkala usulda ham  $n$  nomer ortib borganda ketma-ketlikning hadlar borgan sari nolga yaqinlasha boradi. Agar  $n$  yetarlicha katta son bo'lsa,  $a_n = \frac{1}{n+1}$  ketma-ketlikning  $n$ -hadi noldan juda oz farq qiladi. Bu holat

$$\lim_{n \rightarrow \infty} \frac{1}{n+1} = 0$$

shaklda yoziladi. Bunda  $\{a_n\}$  ketma-ketlikning limiti nolga teng deyiladi.



**1.4. Yaqinlashuvchi va uzoqlashuvchi ketma-ketliklar. Ketma-ketlikning limiti.** Ta'rif. Agar  $a$  sonning har qanday atrofi  $(\alpha; \beta)$  olinganda ham, berilgan  $a_1, a_2, \dots, a_n, \dots$  ketma-ketlikning biror hadi  $a_n$  dan boshlab barcha qolgan hadlari  $(\alpha; \beta)$  da yotsa, bu ketma-ketlik  $a$  ga yaqinlashadi deyilib,  $a$  son shu ketma-ketlikning limiti deyiladi va  $\lim_{n \rightarrow \infty} a_n = a$  yoki  $a_n \rightarrow a$  deb yoziladi.

Ketma-ketlikning qaysi hadidan boshlab qolganlari  $(\alpha; \beta)$  ning ichiga kelib tushishining ahamiyati yo'q, biror hadidan boshlab qolganlari tushsa bas.

Ketma-ketlikning yaqinlashuvchiligini boshqacha ham ta'riflash mumkin.

Ta'rif. Agar avvaldan har qanday kichik musbat son  $\varepsilon > 0$  berilganda ham shunday natural son  $N$  ni topish mumkin bo'lsaki, ketma-ketlikning nomeri  $n > N$  bo'lgan  $a_n$  hadlari ushbu  $|a_n - a| < \varepsilon$  tengsizlikni qanoatlantirsa, berilgan ketma-ketlik  $a$  ga yaqinlashadi deyiladi.

4-misol.  $\lim_{n \rightarrow \infty} \frac{2n}{n+1} = 2$  ekanligini ta'rifga ko'ra isbotlang.

Yechilishi.  $|a_n - 2| = \left| \frac{2n}{n+1} - 2 \right| = \left| \frac{2n - 2n - 2}{n+1} \right| = \left| \frac{-2}{n+1} \right| = \frac{2}{n+1}$ .

Bundan  $n$  o'sishi bilan  $|a_n - 2|$  ning absolut miqdori istagancha kichiklashadi va kichikligicha qoladi.

Masalan,  $n > 20$  bo'lganda bu absolut miqdor 0.1 dan kichik,  $n > 200$  bo'lganda u 0.01 dan kichik bo'ladi va hokazo. Umuman olganda,  $\varepsilon > 0$  har qanday kichik son bo'lganda ham, shunday  $N$  nomer topish mumkinki, barcha  $n > N$  uchun  $|a_n - 2| < \varepsilon$  tengsizlik bajariladi. Haqiqatan ham,  $|a_n - 2| < \frac{2}{n+1}$ ,  $\frac{2}{n+1} < \varepsilon$ , bundan  $n+1 > \frac{2}{\varepsilon}$ ,  $n > \frac{2}{\varepsilon} - 1$ .

$N = \left[ \frac{2}{\varepsilon} - 1 \right]$  (sonning butun qismi) deb olsak,  $|a_n - 2| < \varepsilon$  tengsizlik  $n > \left[ \frac{2}{\varepsilon} - 1 \right] = N$  tengsizlik o'rinli bo'lganda bajariladi.

**Teorema.** Agar ketma-ketlik yaqinlashsa, u faqat bitta limitga ega bo'ladi.

**Teorema.** Agar  $|q| < 1$  bo'lsa, u holda  $\lim_{n \rightarrow \infty} q^n = 0$  bo'ladi.

Isboti. Biz har qanday  $\varepsilon > 0$  uchun shunday  $N$  natural son mavjud bo'lib,  $n > N$  dan  $|q^n - 0| = |q|^n < \varepsilon$  kelib chiqishini ko'rsatishimiz kerak.

$|q| < 1$ , shuning uchun  $\frac{1}{|q|} > 1$ ,  $\frac{1}{|q|} = 1 + \alpha$ , bunda  $\alpha > 0$ . Tenglikning ikkala qismini  $n$ -darajaga ko'taramiz:

$$\frac{1}{|q|^n} = (1 + \alpha)^n.$$

So'ngra

$$\frac{1}{|q|^n} = (1 + \alpha)^n \geq 1 + n\alpha > n\alpha.$$

Bernulli tengsizligidan

$$(1 + \alpha)^n > 1 + n\alpha.$$

Shuning uchun  $\frac{1}{|q|^n} < \frac{1}{n\alpha}$ ,  $N \geq \frac{1}{n\alpha}$  ni olamiz. U vaqtda

$$n > \frac{1}{n\alpha} \cdot n\alpha > \frac{1}{\varepsilon} \cdot \frac{1}{n\alpha} < \varepsilon \cdot \frac{1}{n\alpha} < \varepsilon.$$

Shuni isbotlash talab qilingan edi. Bu teorema misollar yechishda ko'p qo'llanadi.

**1.5. Limitlar haqida teoremlar.** Limitlarni hisoblashda quyidagi uchta teoremdan foydalaniladi.

**Teorema.** Agar  $\{a_n\}$  va  $\{b_n\}$  ketma-ketliklar yaqinlashsa, u holda

$$\lim_{n \rightarrow \infty} (a_n \pm b_n) = \lim_{n \rightarrow \infty} a_n \pm \lim_{n \rightarrow \infty} b_n \text{ bo'ladi.}$$

**Teorema.** Agar  $\{a_n\}$  va  $\{b_n\}$  ketma-ketliklar yaqinlashsa, u holda  $\lim_{n \rightarrow \infty} (a_n \cdot b_n) = \lim_{n \rightarrow \infty} a_n \cdot \lim_{n \rightarrow \infty} b_n$  bo'ladi.

**Teorema natijasi.** O'zgarmas ko'paytuvchini limit belgisidan tashqariga chiqarish mumkin:

$$\lim_{n \rightarrow \infty} (ca_n) = c \cdot \lim_{n \rightarrow \infty} a_n, c \in R.$$

**Teorema.** Agar  $\{a_n\}$  va  $\{b_n\}$  ketma-ketliklar yaqinlashsa va  $\{b_n\}$  ketma-ketlikning limiti noldan farqli bo'lsa, u holda

$$\lim_{n \rightarrow \infty} \frac{a_n}{b_n} = \frac{\lim_{n \rightarrow \infty} a_n}{\lim_{n \rightarrow \infty} b_n}$$

bo'ladi.

## 2-§. Cheksiz kichik ketma-ketliklar

**2.1. Cheksiz kichik tushunchasi.** Ta'rif. *Limiti nolga teng bo'lgan ketma-ketlik cheksiz kichik ketma-ketlik (yoki qisqacha cheksiz kichik) deb ataladi.*

Boshqacha aytganda,  $\{a_n\}$  ketma-ketlik cheksiz kichik bo'lsa, ixtiyoriy  $\varepsilon > 0$  son berilganda ham shunday  $N$  nomerni ko'rsatish mumkinki, bu ketma-ketlikning  $N$  dan katta  $n$  nomerli barcha hadlari  $|a_n - 0| < \varepsilon$  yoki  $|a_n| < \varepsilon$  shartni qanoatlantiradi.

1-misol.  $\left\{\frac{1}{n}\right\}$  ketma-ketlikni cheksiz kichik ekanligini isbotlang.

Isboti.  $\varepsilon$  ixtiyoriy kichik musbat son bo'lsin.  $\left|\frac{1}{n} - 0\right| < \varepsilon$  yoki  $\frac{1}{n} < \varepsilon$  tengsizlik o'rinli bo'lishi uchun  $n > \frac{1}{\varepsilon}$  bo'lishi kerak.  $\left[\frac{1}{\varepsilon}\right] = N$  deb belgilasak,  $\frac{1}{n} < \varepsilon$  tengsizlik  $n$  ning  $n > \left[\frac{1}{\varepsilon}\right] = N$  qiymatlarida o'rinli bo'ladi, ya'ni  $\lim_{n \rightarrow \infty} \frac{1}{n} = 0$ . Demak,  $\left\{\frac{1}{n}\right\}$  cheksiz kichik ketma-ketlikdir.

**2.2. Cheksiz kichiklarning ba'zi xossalari.** Teorema. *Ikki, uch va umuman, chekli sondagi cheksiz kichiklarning algebraik yig'indisi cheksiz kichik bo'ladi.*

Ya'ni

$$\lim_{n \rightarrow \infty} \alpha_n = 0, \lim_{n \rightarrow \infty} \beta_n = 0, \dots, \lim_{n \rightarrow \infty} \gamma_n = 0$$

bo'lsa,

$$\lim_{n \rightarrow \infty} (\alpha_n + \beta_n + \dots + \gamma_n) = 0$$

bo'ladi.

**Teorema.** *Chegaralangan ketma-ketlik bilan cheksiz kichikning ko'paytmasi cheksiz kichikdir.*

**Teorema.**  $\{a_n\}$  ketma-ketlikning limiti  $a$  bo'lishi uchun

$$x_n - a = \alpha_n$$

*bo'lishi zarur va yetarlidir.*

1-natija. O'zgarmas son bilan cheksiz kichikning ko'paytmasi cheksiz kichikdir.

2-natija. Ikki cheksiz kichikning ko'paytmasi ham cheksiz kichikdir.

3-natija.  $\{a_n\}$  ketma-ketlik bilan o'zgarmas  $a$  ning ayirmasi cheksiz kichik bo'lsa, bu ketma-ketlikning limiti shu o'zgarmas son-dan iborat bo'ladi, ya'ni  $\lim_{n \rightarrow \infty} \alpha_n = a$ .

Yuqoridagi teoremlar va natijalardan foydalanib, limitlarni hisoblashga doir misollarni ko'ramiz.

2-misol.  $\lim_{n \rightarrow \infty} 2\left(3 + \frac{1}{n}\right)\left(\frac{1}{n} - 4\right)$  ni hisoblang.

$$\begin{aligned} \text{Yechilishi: } \lim_{n \rightarrow \infty} 2\left(3 + \frac{1}{n}\right)\left(\frac{1}{n} - 4\right) &= 2 \lim_{n \rightarrow \infty} \left(3 + \frac{1}{n}\right) \cdot \lim_{n \rightarrow \infty} \left(\frac{1}{n} - 4\right) = \\ &= 2 \left( \lim_{n \rightarrow \infty} 3 + \lim_{n \rightarrow \infty} \frac{1}{n} \right) \left( \lim_{n \rightarrow \infty} \frac{1}{n} - \lim_{n \rightarrow \infty} 4 \right) = 2(3+0)(0-4) = -24. \end{aligned}$$

Javob:  $-24$ .

3-misol.  $\lim_{n \rightarrow \infty} \frac{5n-7}{3n+2}$  ni hisoblang.

Yechilishi. Kasrning surati ham, maxraji ham chegaralanma-gan ketma-ketliklar bo'lganidan bo'linmaning limiti haqidagi teore-mani qo'llab bo'lmaydi. Shu sababli kasrning suratini ham, maxra-jini ham  $n$  ga bo'lib, so'ngra bo'linmaning limiti haqidagi teore-madan foydalanamiz:

$$\lim_{n \rightarrow \infty} \frac{5n-7}{3n+2} = \lim_{n \rightarrow \infty} \frac{5-\frac{7}{n}}{3+\frac{2}{n}} = \frac{\lim_{n \rightarrow \infty} \left(5-\frac{7}{n}\right)}{\lim_{n \rightarrow \infty} \left(3+\frac{2}{n}\right)} = \frac{\lim_{n \rightarrow \infty} 5 - \lim_{n \rightarrow \infty} \frac{7}{n}}{\lim_{n \rightarrow \infty} 3 + \lim_{n \rightarrow \infty} \frac{2}{n}} = \frac{5-0}{3+0} = \frac{5}{3} = 1\frac{2}{3}.$$

Javob:  $1\frac{2}{3}$ .

4-misol.  $\lim_{n \rightarrow \infty} \frac{4n^2-2n+7}{3n^4+n^2-5n+9}$  ni hisoblang.

Yechilishi. Kasrning surati va maxrajini  $n^4$  ga bo'lamiz, so'ngra limitini hisoblaymiz:

$$\begin{aligned} \lim_{n \rightarrow \infty} \frac{4n^2-2n+7}{3n^4+n^2-5n+9} &= \lim_{n \rightarrow \infty} \frac{n^2-n^3+n^3}{3+n^2-n^3+n^4} = \lim_{n \rightarrow \infty} \frac{\overset{4}{n^2}-\overset{2}{n^3}+\overset{2}{n^3}}{\overset{1}{3}+\overset{5}{n^2}-\overset{9}{n^3}+\overset{9}{n^4}} = \\ &= \frac{\lim_{n \rightarrow \infty} n^2 - \lim_{n \rightarrow \infty} n^3 + \lim_{n \rightarrow \infty} n^3}{\lim_{n \rightarrow \infty} 3 + \lim_{n \rightarrow \infty} n^2 - \lim_{n \rightarrow \infty} n^3 + \lim_{n \rightarrow \infty} n^4} = \frac{0-0+0}{3+0-0+0} = \frac{0}{3} = 0. \end{aligned}$$

Javob:  $0$ .

5-misol.  $\lim_{n \rightarrow \infty} (\sqrt{n^2 + 2n} - n)$  ni hisoblang.

Yechilishi. Kamayuvchining ham, ayriluvchining ham limiti mavjud bo'lmaganligi uchun ayirmaning limiti haqidagi teoremani qo'llab bo'lmaydi. Shu sababli berilgan ifodani qo'shmasiga ham ko'paytiramiz, ham bo'lamiz:

$$\begin{aligned} \lim_{n \rightarrow \infty} (\sqrt{n^2 + 2n} - n) &= \lim_{n \rightarrow \infty} \frac{(\sqrt{n^2 + 2n} - n)(\sqrt{n^2 + 2n} + n)}{\sqrt{n^2 + 2n} + n} = \\ &= \lim_{n \rightarrow \infty} \frac{n^2 + 2n - n^2}{\sqrt{n^2 + 2n} + n} = \lim_{n \rightarrow \infty} \frac{2n}{\sqrt{n^2 + 2n} + n} = \lim_{n \rightarrow \infty} \frac{2}{\sqrt{1 + \frac{2}{n}} + 1} = \frac{2}{\sqrt{1+0} + 1} = \frac{2}{1} = 2. \end{aligned}$$

Javob: 2.

### 3-§. Arifmetik progressiya

Ta'rif. Ikkinchi hadidan boshlab har bir hadi o'zidan oldingi had bilan biror o'zgarmas son yig'indisiga teng bo'ladigan sonli ketma-ketlik arifmetik progressiya deyiladi.

Ushbu  $\div$  belgi arifmetik progressiyani belgisi sifatida qabul qilingan. Masalan:

$$\div 3; 1,5; 0; -1,5; -3; \dots$$

$$\div 1; 2; 3; \dots$$

$$\div 3; 6; 9; \dots$$

Agar  $\div a_1, a_2, \dots, a_n, \dots$  berilgan bo'lsa har qanday  $n$  uchun

$$a_{n+1} = a_n + d$$

tenglik bajariladi, bunda  $d$  — berilgan ketma-ketlik uchun o'zgarmas biror son. Bu  $d$  son progressiyaning ayirmasi deyiladi.  $a_1$  — birinchi hadi,  $a_n$  esa  $n$  hadi va u quyidagicha topiladi:

$$a_n = a_1 + (n-1)d. \quad (1)$$

Arifmetik progressiyaning dastlabki  $n$  ta hadining yig'indisi quyidagicha topiladi:

$$S_n = \frac{a_1 + a_n}{2} \cdot n \text{ yoki } S_n = \frac{2a_1 + (n-1)d}{2} \cdot n. \quad (2)$$

#### Arifmetik progressiyaning xossalari

1-xossa. Arifmetik progressiyaning ikkinchi hadidan boshlab har bir hadi, o'ziga qo'shni hadlarning o'rta arifmetigiga teng:

$$a_n = \frac{a_{n-1} + a_{n+1}}{2} \quad (3)$$

2-xossa. Agar  $m, n, k, l$  lar arifmetik progressiyaning ixtiyoriy hadlari nomerlari bo'lib,  $m + n = k + l$  tenglik bajarilsa, u holda

$$a_m + a_n = a_k + a_l \quad (4)$$

bo'ladi.

(1) va (2) tengliklardan kelib chiqadigan quyidagi ikkita tenglik ham misol va masalalar yechishda muhim ahamiyatga ega:

$$a_n - a_k = (n - k)d \quad (5)$$

$$S_n - S_{n-1} = a_n \quad (6)$$

1-misol. Arifmetik progressiyada  $a_2 = 10, a_5 = 22$ . Shu progressiyaning dastlabki sakkizta hadining yig'indisini toping.

Yechilishi: (5) formuladan foydalansak,

$$a_5 - a_2 = (5 - 2)d;$$

bundan arifmetik progressiyaning ayirmasini topamiz:

$$22 - 10 = 3d, \quad d = 4.$$

Endi  $a_2 = a_1 + d$  dan  $a_1 = 6$  ekanligi kelib chiqadi va (2) formuladan

foydalanib,  $S_8 = \frac{2 \cdot 6 + 7 \cdot 4}{2} \cdot 8 = 160$  ekanligini topamiz.

Javob: 160.

2-misol.  $\{a_n\}$  arifmetik progressiyaning dastlabki  $n$  ta hadi yig'indisi 120 ga teng. Agar  $a_3 + a_{n-2} = 30$  bo'lsa, yig'indida nechta had qatnashgan?

Yechilishi. Dastlabki  $n$  ta hadi yig'indisi formulasi (2)

$$S_n = \frac{a_1 + a_n}{2} \cdot n$$

dan foydalaniladi.

Arifmetik progressiyaning 2-xossasiga ko'ra

ekanligidan,  $a_1 + a_n = a_3 + a_{n-2}$  kelib chiqadi. U holda

$$120 = \frac{30}{2} \cdot n \Rightarrow [n = 8.$$

Javob: 8.

3-misol. Hadlari  $x_n = 4n + 5$  formula bilan berilgan ketma-ketlikning dastlabki o'ttizta hadi yig'indisini toping.

Yechilishi. Avvalo ketma-ketlik arifmetik progressiya ekanligini isbotlaymiz. Buning uchun progressiyaning 1-xossasidan foydalanamiz. Unga ko'ra

$$x_n = \frac{x_{n-1} + x_{n+1}}{2}$$

bo'lishi kerak.

$$4n + 5 = \frac{4(n-1) + 5 + 4(n+1) + 5}{2};$$

$$4n + 5 = \frac{4n - 4 + 10 + 4n + 4}{2},$$

$4n + 5 = 4n + 5$  tenglik bajarildi. Demak, berilgan ketma-ketlik arifmetik progressiya ekan. U holda  $x_1 = 9$ ,  $x_{30} = 125$  ga teng. Demak,

$$S_{30} = \frac{9 + 125}{2} \cdot 30 = 2110.$$

Javob: 2110.

4-misol. Dastlabki yettita hadining yig'indisi  $-266$  ga, dastlabki sakkizta hadining yig'indisi  $-312$  ga va hadlarining ayirmasi  $-2$  ga teng bo'lgan arifmetik progressiyaning birinchi hadini toping.

Yechilishi. Masala shartiga ko'ra  $S_7 = -266$ ,  $S_8 = -312$ ,  $d = -2$ . (6) formuladan foydalanib  $S_8 - S_7 = a_8$  tenglikdan, quyidagini topamiz:

$$a_8 = -312 - (-266) = -46, a_8 = a_1 + 7d \text{ tenglikdan } a_1 = -46 - 7 \cdot (-2) = -32.$$

Javob:  $-32$ .

#### 4-§. Geometrik progressiya

Ta'rif. Birinchi hadi noldan farqli, ikkinchi hadidan boshlab qolgan hadlari o'zidan oldingi hadini noldan farqli biror o'zgarmas songa ko'paytirishdan hosil qilingan ketma-ketlik geometrik progressiya deyiladi.

Geometrik progressiyani  $\dots$  belgi bilan belgilash qabul qilingan. Masalan,

$$\dots \frac{1}{2}, \frac{1}{4}, \frac{1}{8}, \dots$$

$$\dots 1, -1, 1, -1, \dots$$

$$\dots 2, -4, 8, -16, \dots$$

$\dots b_1, b_2, \dots, b_n, \dots$  geometrik progressiya berilgan bo'lsa, har qanday  $n$  uchun  $b_{n+1} = b_n \cdot q$  tenglik bajariladi, bunda  $q$  – berilgan ketma-ketlik uchun o'zgarmas, noldan farqli son. Bu  $q$  son geometrik progressiyaning *maxraji* deyiladi. Geometrik progressiyaning  $n$ -hadi  $b_n$  quyidagi formula bilan topiladi:

$$b_n = b_1 \cdot q^{n-1}. \quad (1)$$

Geometrik progressiyaning dastlabki  $n$  ta hadining yig'indisi quyidagi formulalar yordamida topiladi:

$$S_n = \frac{b_n q - b_1}{q-1} \quad \text{yoki} \quad S_n = \frac{b_1 (q^n - 1)}{q-1}, \quad (2)$$

bunda  $q \neq 1$ .

### Geometrik progressiyaning xossalari

1-xossa. Musbat hadli geometrik progressiya uchun

$$b_n^2 = b_{n+1} \cdot b_{n-1} \quad (3)$$

tenglik o'rinli, ya'ni geometrik progressiyaning ikkinchi hadidan boshlab har bir hadi o'ziga qo'shni hadlarning o'rta geometrigiga teng:

$$b_n = \sqrt{b_{n-1} \cdot b_{n+1}}.$$

2-xossa. Agar  $m, n, k, l$  lar geometrik progressiyaning ixtiyoriy hadlari nomerlari bo'lib,

$$m + n = k + l$$

tenglik bajarilsa, u holda

$$b_m \cdot b_n = b_k \cdot b_l \quad (4)$$

tenglik o'rinli bo'ladi.

(1) va (2) tengliklardan kelib chiqadigan ushbu hosilaviy tengliklar misol va masalalar yechishda muhim ahamiyatga ega:

$$S_n - S_{n-1} = b_n, \quad (5)$$

$$\frac{b_n}{b_k} = q^{n-k}. \quad (6)$$

1-misol. 4 va 9 sonlari orasiga shunday musbat sonni qo'yingki, natijada geometrik progressiyaning ketma-ket uchta hadi hosil bo'lsin.

Yechilishi. (3) formulaga ko'ra  $b_1 = 4, b_3 = 9$  uchun

$$b_2 = \sqrt{4 \cdot 9} = \sqrt{36} = 6.$$

Javob: 6.

2-misol. Geometrik progressiyada uchinchi va yettinchi hadlarining ko'paytmasi 144 ga teng. Uning beshinchi hadini toping.

Yechilishi. (4) formuladan foydalanamiz:

$$b_3 \cdot b_7 = b_5 \cdot b_5, \quad b_5^2 = 144, \quad b_5 = \pm 12.$$

Javob:  $\pm 12$ .



3-misol. Yig'indisi 35 ga teng bo'lgan uchta son o'suvchi geometrik progressiyaning dastlabki uchta hadi. Agar shu sonlardan mos ravishda 2; 2 va 7 sonlarini ayirilsa, hosil bo'lgan sonlar arifmetik progressiyaning ketma-ket hadlari bo'ladi. Arifmetik progressiyaning dastlabki 10 ta hadining yig'indisini toping.

Yechilishi:  $\ddot{\vdots} b_1, b_2, b_3$ , va  $b_1 + b_2 + b_3 = 35$  berilgan.  $q > 1$ .  
 $\div b_1 - 2; b_2 - 2; b_3 - 7$  hosil bo'ladi.

Arifmetik progressiyaning xossasidan  $2(b_2 - 2) = b_1 - 2 + b_3 - 7$  tenglik kelib chiqadi. Masala ushbu

$$\begin{cases} b_1 + b_3 - 2b_2 = 5, \\ b_1 + b_2 + b_3 = 35 \end{cases}$$

tenglamalar sistemasini yechishga keltiriladi. Uni yechamiz:

$$\begin{cases} b_1 - 2b_1q + b_1q^2 = 5 \\ b_1 + b_1q + b_1q^2 = 35 \end{cases} \Leftrightarrow \begin{cases} b_1(1 - 2q + q^2) = 5 \\ b_1(1 + q + q^2) = 35 \end{cases} \Leftrightarrow \frac{1 + q + q^2}{1 - 2q + q^2} = 7 \Leftrightarrow$$

$$\Leftrightarrow 1 + q + q^2 = 7 - 14q + 7q^2 \Leftrightarrow 6q^2 - 15q + 6 = 0 \Leftrightarrow 2q^2 - 5q + 2 = 0 \Leftrightarrow$$

$$\Leftrightarrow q_{1,2} = \frac{5 \pm 3}{4} \left[ q_1 = 2, q_2 = \frac{1}{2} \right].$$

Masala shartiga ko'ra geometrik progressiya o'suvchi bo'lganligi uchun  $q = 2$  bo'ladi. Bundan  $b_1(1 - 2 \cdot 2 + 4) = 5 \Rightarrow [b_1 = 5$ .

$\ddot{\vdots} 5, 10, 20, \dots$

$\div 3, 8, 13, \dots$  va arifmetik progressiya ayirmasi  $d = 5$  bo'ladi.

$$S_{10} = \frac{2 \cdot 3 + 9 \cdot 5}{2} \cdot 10 = 51 \cdot 5 = 255.$$

Javob: 255.

4-masala. Oltita haddan iborat geometrik progressiyaning dastlabki uchta hadining yig'indisi 168 ga, keyingi uchta hadiniki esa 21 ga teng. Shu progressiyaning maxrajini toping.

Yechilishi:  $\ddot{\vdots} b_1, b_2, b_3, b_4, b_5, b_6$ . Masala shartiga ko'ra

$$\begin{cases} b_1 + b_2 + b_3 = 168, \\ b_4 + b_5 + b_6 = 21 \end{cases} \Leftrightarrow \begin{cases} b_1 + b_1q + b_1q^2 = 168, \\ b_1q^3 + b_1q^4 + b_1q^6 = 21 \end{cases} \Leftrightarrow$$

$$\Leftrightarrow \begin{cases} b_1(1+q+q^2) = 168, \\ b_1q^3(1+q+q^2) = 21 \end{cases} \Leftrightarrow \frac{b_1(1+q+q^2)}{b_1q^3(1+q+q^2)} = \frac{168}{21} \Rightarrow \frac{1}{q^3} = 8 \Rightarrow$$

$$\Rightarrow q^3 = \frac{1}{8} \Rightarrow \left[ q = \frac{1}{2} \right].$$

### 5-§. Cheksiz kamayuvchi geometrik progressiya

Ta'rif. Maxrajining moduli birdan kichik bo'lgan geometrik progressiya cheksiz kamayuvchi geometrik progressiya deyiladi va  $\ddot{=} b_1, b_2, b_3, \dots, b_n, \dots$  kabi yoziladi. Bunda  $|q| < 1$ .

Cheksiz kamayuvchi geometrik progressiyaning yig'indisi deb  $n \rightarrow \infty$  da uning dastlabki  $n$  ta hadining yig'indisi intiladigan songa aytiladi va u quyidagiga teng:

$$S = \frac{b_1}{1-q}. \quad (1)$$

1-misol.  $\ddot{=} \frac{1}{2}, -\frac{1}{6}, \frac{1}{18}, -\frac{1}{54}, \dots$  cheksiz kamayuvchi geometrik progressiyaning yig'indisini toping.

Yechilishi:  $b_1 = \frac{1}{2}, b_2 = -\frac{1}{6}$  bo'lgani uchun  $q = \frac{b_2}{b_1} = -\frac{1}{3}$ . (1) formuladan

$$S = \frac{\frac{1}{2}}{1 - \left(-\frac{1}{3}\right)} = \frac{3}{8}.$$

Javob:  $\frac{3}{8}$ .

2-misol. Cheksiz kamayuvchi geometrik progressiyaning birinchi hadi ikkinchisidan 8 ga ortiq, hadlarining yig'indisi esa 18 ga teng. Progressiyaning uchinchi hadini toping.

Yechilishi. Masala shartiga ko'ra  $b_1 = b_2 + 8$ ,  $S = 18$ . Bundan

$$\begin{cases} b_1 = b_1 q + 8, \\ \frac{b_1}{1-q} = 18 \end{cases} \Leftrightarrow \begin{cases} b_1(1-q) = 8, \\ \frac{b_1}{1-q} = 18 \end{cases} \Leftrightarrow \begin{cases} b_1 = \frac{8}{1-q} \\ \frac{8}{1-q} = 18 \end{cases} \Leftrightarrow \frac{8}{(1-q)^2} = 18 \Leftrightarrow$$

$$\Leftrightarrow \frac{8}{18} = (1-q)^2 \Leftrightarrow \frac{4}{9} = (1-q)^2 \Leftrightarrow (1-q) = \pm \frac{2}{3} \Rightarrow q = 1 \pm \frac{2}{3} \begin{cases} q_1 = 1\frac{2}{3}, \\ q_2 = \frac{1}{3}. \end{cases}$$

Progressiya cheksiz kamayuvchi bo'lganligidan  $q = \frac{1}{3}$ ,  $b_1$  ni topamiz:

$$b_1 = \frac{8}{1-\frac{1}{3}} = \frac{8}{\frac{2}{3}} = 12 \Rightarrow [b_1 = 12.$$

$b_3$  ni topamiz:

$$b_3 = 12 \cdot \left(\frac{1}{3}\right)^2 = 12 \cdot \frac{1}{9} = \frac{4}{3} = 1\frac{1}{3}.$$

Javob:  $1\frac{1}{3}$ .

### Mustaqil ishlash uchun test topshiriqlari

1. Quyidagi ketma-ketlikning oltinchi hadini toping:

$$a_n = \frac{3n^2 - 1}{n^2 + 1}.$$

A)  $\frac{107}{37}$ ; B)  $\frac{109}{37}$ ; C)  $\frac{110}{37}$ ; D)  $\frac{106}{37}$ ; E)  $\frac{105}{37}$ .

2. Quyidagi sonlardan qaysi biri  $a_n = n^2 - 17n$  ketma-ketlikning hadi bo'la oladi?

A) -30; B) -72; C) -100; D) -15; E) -14.

3. Quyidagi ketma-ketlikning  $n$ -hadi formulasini toping.

$3 \cdot 2$ ;  $5 \cdot 2^2$ ;  $7 \cdot 2^3$ ;  $9 \cdot 2^4$ ;  $11 \cdot 2^5$ ; ...

A)  $(2n - 1) \cdot 2^n$ ; B)  $(2n + 1) \cdot 2^n$ ; C)  $(2n + 1) \cdot 2^{n+1}$ ;

D)  $(2n + 1) \cdot 2^{n-1}$ ; E)  $(2n - 1) \cdot 2^{n+1}$ .

4.  $\lim_{n \rightarrow \infty} \frac{5n+6}{n+1}$  ni hisoblang.

- A) 6;      B) 4;      C)  $\frac{5}{2}$ ;      D) 5;      E)  $\frac{3}{2}$ .

5\*. Hisoblang:  $\lim_{n \rightarrow \infty} \frac{1+2+\dots+n}{n^2}$ .

- A)  $\frac{1}{2}$ ;      B)  $\frac{1}{3}$ ;      C)  $\frac{1}{4}$ ;      D)  $\frac{2}{3}$ ;      E)  $\frac{3}{4}$ .

6\*.  $\{a_n\}$  ketma-ketlik  $a_n = \frac{3n+5}{2n}$  formula bilan berilgan.  $n$  ning qanday natural qiymatlarida  $|a_n - 1,5| < 0,01$  tengsizlik o'rinli bo'ladi?

- A)  $n \geq 26$ ;      B)  $n \geq 261$ ;      C)  $n \geq 251$ ;      D)  $n \geq 161$ ;      E)  $n \geq 250$ .

7\*.  $\{x_n\}$  ketma-ketlik  $x_n = \frac{2n-3}{n}$  formula bilan berilgan.  $n$  ning qanday natural qiymatlarida  $|x_n - 2| < 0,01$  shart bajariladi?

- A)  $n \geq 301$ ;      B)  $n \geq 31$ ;      C)  $n \geq 311$ ;      D)  $n \geq 300$ ;      E)  $n \geq 310$ .

8. Agar ketma-ketlikda  $a_1 = 9$ ,  $a_{n+1} = 3a_n$  bo'lsa, uning oltinchi hadini toping.

- A) 18;      B) 81;      C) 27;      D) 927;      E) 2187.

9. Sonli ketma-ketlik  $a_{n+2} = a_n^2 - a_{n+1}$  rekurrent formula bilan berilgan. Agar  $a_1 = 2$ ,  $a_2 = 3$  bo'lsa, ketma-ketlikning beshinchi hadini toping.

- A) 5;      B) -7;      C) -5;      D) 9;      E) -9.

10. Agar 5; 9; 13; 17; ... arifmetik progressiyaning hadlarining yig'indisi 10877 ga teng bo'lsa, progressiyaning hadlari sonini toping.

- A) 53;      B) 61;      C) 63;      D) 73;      E) 83.

11. Arifmetik progressiyaning hadlari soni 20 ga teng. Juft o'rinda turgan hadlarining yig'indisi 250 ga, toq o'rinda turgan hadlarining yig'indisi 220 ga teng. Shu progressiyaning o'ninchi va o'n birinchi hadlari yig'indisini toping.

- A) 47;      B) 22;      C) 25;      D) 36;      E) 57.

12\*. Arifmetik progressiyada  $a_1 + a_3 = 24$ ,  $a_2 \cdot a_3 = 60$ . Progressiyaning ayirmasini toping.

- A) 2;      B) 3;      C) 4;      D) 6;      E) 7.

13\*. Arifmetik progressiyada  $a_{17} = 2$  ga teng bo'lsa,  $S_{21} - S_{12}$  ni toping.

- A) 18;      B) 15;      C) 16;      D) 17;      E) 19.

14\*. O'zidan oldin kelgan barcha toq natural sonlar yig'indisi-ning  $\frac{1}{6}$  qismiga teng bo'lgan natural sonni toping.

A) 18;      B) 30;      C) 24;      D) 36;      E) 48.

15. 5 va 1 sonlari orasiga shu sonlar bilan arifmetik progressiya tashkil etadigan bir nechta son joylashtirildi. Agar bu sonlarning yig'indisi 33 ga teng bo'lsa, nechta had joylashtirilgan?

A) 11;      B) 10;      C) 9;      D) 12;      E) 6.

16. Arifmetik progressiyaning uchinchi va beshinchi hadlari mos ravishda 11 va 19 ga teng bo'lsa, uning dastlabki o'n ta hadining yig'indisi qanchaga teng bo'ladi?

A) 210;      B) 190;      C) 230;      D) 220;      E) 240.

17. Arifmetik progressiya dastlabki  $n$  ta hadining yig'indisi  $S_n = n^2$  bo'lsa, uning o'ninchi hadini toping.

A) 100;      B) 15;      C) 23;      D) 19;      E) 121.

18. Arifmetik progressiyada  $S_{20} - S_{19} = -30$  va  $d = -4$  bo'lsa,  $a_{25}$  ni toping.

A) -40;      B) -50;      C) -48;      D) -56;      E) -42.

19. 150 dan katta bo'lmagan 6 ga karrali barcha natural sonlarning yig'indisini toping.

A) 1800;      B) 2024;      C) 1760;      D) 1950;      E) 2100.

20. Arifmetik progressiyada  $a_1 + a_6 = 10$  bo'lsa,  $S_9$  ni toping.

A) 25;      B) 30;      C) 35;      D) 40;      E) 45.

21.  $a_n = 4n - 2$  formula bilan berilgan ketma-ketlikning dastlabki 50 ta hadining yig'indisini toping.

A) 4500;      B) 5050;      C) 3480;      D) 4900;      E) 5000.

22. Quvurlar ustma-ust taxlangan. Birinchi qatlamda 11 ta, ikkinchisida 10 ta va h.k. oxirgi qatlamda 1 ta quvur bor. Taxlamda nechta quvur bor?

A) 66;      B) 67;      C) 68;      D) 65;      E) 64.

23. Agar geometrik progressiyada  $b_1 + b_9 = 5$  va  $b_1^2 + b_9^2 = 17$  bo'lsa,  $b_4 \cdot b_6$  ni toping.

A) 4;      B) 3;      C) 2;      D) 1;      E) 9.

24. Geometrik progressiyaning dastlabki 6 ta hadi 2,  $b_2$ ,  $b_3$ ,  $b_4$ ,  $b_5$  va 486 bo'lsa,  $b_2 + b_3 + b_4 + b_5$  ni hisoblang.

A) 200;      B) 260;      C) 230;      D) 250;      E) 240.

25. Geometrik progressiyaning maxraji 3, dastlabki to'rtta hadining yig'indisi 80 ga teng. Uning to'rtinchi hadini toping.

A) 24;      B) 32;      C) 54;      D) 27;      E) 57.

26. Maxraji 2 ga teng bo'lgan geometrik progressiyaning dastlabki oltita hadining yig'indisi 126 ga, dastlabki 5 ta hadining yig'indisi 62 ga teng. Progressiyaning birinchi hadini toping.

- A) 6;      B) 5;      C) 4;      D) 2;      E) 3.

27. O'suvchi geometrik progressiyaning dastlabki to'rtta hadi yig'indisi 15 ga, undan keyingi to'rttasiniki esa 240 ga teng. Shu progressiyaning dastlabki oltita hadining yig'indisini toping.

- A) 31;      B) 48;      C) 63;      D) 127;      E) 144.

28. Ishorasi almashinuvchi geometrik progressiyaning birinchi hadi 2 ga, uchinchi hadi 8 ga teng. Shu progressiyaning dastlabki oltita hadining yig'indisini toping.

- A) 20;      B) -20;      C) -42;      D) 42;      E) -64.

29. Geometrik progressiyada  $q = 2$  va  $S_4 = 5$  bo'lsa,  $b_5$  ni toping.

- A) 0.4;      B) 0.8;      C)  $1\frac{1}{3}$ ;      D)  $\frac{2}{3}$ ;      E)  $\frac{5}{6}$ .

30. Geometrik progressiyaning yig'indisini toping:

$$\sqrt{5}; 1; \frac{1}{\sqrt{5}}; \dots$$

- A)  $\frac{5}{\sqrt{5}-1}$ ;      B)  $\frac{6\sqrt{5}+5}{5}$ ;      C)  $\frac{\sqrt{5}-1}{\sqrt{5}}$ ;      D) 4. 16;      E) 4.5.

31\*. Hisoblang:

$$\sqrt[3]{3\sqrt[3]{3\sqrt[3]{3\sqrt[3]{3\dots}}}}$$

- A)  $\sqrt[4]{3}$ ;      B)  $\sqrt[3]{3}$ ;      C) 1;      D)  $\sqrt{3}$ ;      E) 3.

32. Cheksiz kamayuvchi geometrik progressiyaning birinchi hadi 3 ga, hadlarining yig'indisi esa  $\frac{9}{2}$  ga teng. Shu progressiyaning uchinchi hadini toping.

- A)  $\frac{2}{3}$ ;      B)  $\frac{1}{2}$ ;      C)  $\frac{3}{4}$ ;      D)  $\frac{1}{4}$ ;      E)  $\frac{1}{3}$ .

33\*. Birinchisi ikkichisidan 36 ga ortiq, uchinchi to'rtinchisidan 4 ga ortiq bo'lgan 4 ta son geometrik progressiyani hosil qiladi. Progressiyaning maxrajini toping.

- A)  $\pm\frac{1}{2}$ ;      B)  $\frac{1}{3}$ ;      C)  $-\frac{1}{3}$ ;      D)  $\pm\frac{1}{3}$ ;      E)  $\pm 3$ .

A) 18;      B) 30;      C) 24;      D) 36;      E) 48.

15. 5 va 1 sonlari orasiga shu sonlar bilan arifmetik progressiya tashkil etadigan bir nechta son joylashtirildi. Agar bu sonlarning yig'indisi 33 ga teng bo'lsa, nechta had joylashtirilgan?

A) 11;      B) 10;      C) 9;      D) 12;      E) 6.

16. Arifmetik progressiyaning uchinchi va beshinchi hadlari mos ravishda 11 va 19 ga teng bo'lsa, uning dastlabki o'n ta hadining yig'indisi qanchaga teng bo'ladi?

A) 210;      B) 190;      C) 230;      D) 220;      E) 240.

17. Arifmetik progressiya dastlabki  $n$  ta hadining yig'indisi  $S_n = n^2$  bo'lsa, uning o'ninchi hadini toping.

A) 100;      B) 15;      C) 23;      D) 19;      E) 121.

18. Arifmetik progressiyada  $S_{20} - S_{19} = -30$  va  $d = -4$  bo'lsa,  $a_{25}$  ni toping.

A) -40;      B) -50;      C) -48;      D) -56;      E) -42.

19. 150 dan katta bo'lmagan 6 ga karrali barcha natural sonlarning yig'indisini toping.

A) 1800;      B) 2024;      C) 1760;      D) 1950;      E) 2100.

20. Arifmetik progressiyada  $a_3 + a_6 = 10$  bo'lsa,  $S_9$  ni toping.

A) 25;      B) 30;      C) 35;      D) 40;      E) 45.

21.  $a_n = 4n - 2$  formula bilan berilgan ketma-ketlikning dastlabki 50 ta hadining yig'indisini toping.

A) 4500;      B) 5050;      C) 3480;      D) 4900;      E) 5000.

22. Quvurlar ustma-ust taxlangan. Birinchi qatlamda 11 ta, ikkinchisida 10 ta va h.k. oxirgi qatlamda 1 ta quvur bor. Taxlamda nechta quvur bor?

A) 66;      B) 67;      C) 68;      D) 65;      E) 64.

23. Agar geometrik progressiyada  $b_1 + b_9 = 5$  va  $b_1^2 + b_9^2 = 17$  bo'lsa,  $b_4 \cdot b_6$  ni toping.

A) 4;      B) 3;      C) 2;      D) 1;      E) 9.

24. Geometrik progressiyaning dastlabki 6 ta hadi 2,  $b_2$ ,  $b_3$ ,  $b_4$ ,  $b_5$  va 486 bo'lsa,  $b_2 + b_3 + b_4 + b_5$  ni hisoblang.

A) 200;      B) 260;      C) 230;      D) 250;      E) 240.

25. Geometrik progressiyaning maxraji 3, dastlabki to'rtta hadining yig'indisi 80 ga teng. Uning to'rtinchi hadini toping.

A) 24;      B) 32;      C) 54;      D) 27;      E) 57.

26. Maxraji 2 ga teng bo'lgan geometrik progressiyaning dastlabki oltita hadining yig'indisi 126 ga, dastlabki 5 ta hadining yig'indisi 62 ga teng. Progressiyaning birinchi hadini toping.

- A) 6; B) 5; C) 4; D) 2; E) 3.

27. O'suvchi geometrik progressiyaning dastlabki to'rtta hadi yig'indisi 15 ga, undan keyingi to'rttasiniki esa 240 ga teng. Shu progressiyaning dastlabki oltita hadining yig'indisini toping.

- A) 31; B) 48; C) 63; D) 127; E) 144.

28. Ishorasi almashinuvchi geometrik progressiyaning birinchi hadi 2 ga, uchinchi hadi 8 ga teng. Shu progressiyaning dastlabki oltita hadining yig'indisini toping.

- A) 20; B) -20; C) -42; D) 42; E) -64.

29. Geometrik progressiyada  $q = 2$  va  $S_4 = 5$  bo'lsa,  $b_2$  ni toping.

- A) 0,4; B) 0,8; C)  $1\frac{1}{3}$ ; D)  $\frac{2}{3}$ ; E)  $\frac{5}{6}$ .

30. Geometrik progressiyaning yig'indisini toping:

$$\sqrt{5}; 1; \frac{1}{\sqrt{5}}; \dots$$

- A)  $\frac{5}{\sqrt{5}-1}$ ; B)  $6\sqrt{5}+5$ ; C)  $\frac{\sqrt{5}-1}{\sqrt{5}}$ ; D) 4, 16; E) 4,5.

31\*. Hisoblang:

$$\sqrt[3]{3\sqrt[3]{3\sqrt[3]{3\sqrt[3]{3\sqrt[3]{3\dots}}}}}$$

- A)  $\sqrt[4]{3}$ ; B)  $\sqrt[6]{3}$ ; C) 1; D)  $\sqrt{3}$ ; E) 3.

32. Cheksiz kamayuvchi geometrik progressiyaning birinchi hadi 3 ga, hadlarining yig'indisi esa  $\frac{9}{2}$  ga teng. Shu progressiyaning uchinchi hadini toping.

- A)  $\frac{2}{3}$ ; B)  $\frac{1}{2}$ ; C)  $\frac{3}{4}$ ; D)  $\frac{1}{4}$ ; E)  $\frac{1}{3}$ .

33\*. Birinchisi ikkichisidan 36 ga ortiq, uchinchi to'rtinchisidan 4 ga ortiq bo'lgan 4 ta son geometrik progressiyani hosil qiladi. Progressiyaning maxrajini toping.

- A)  $\pm\frac{1}{2}$ ; B)  $\frac{1}{3}$ ; C)  $-\frac{1}{3}$ ; D)  $\pm\frac{1}{3}$ ; E)  $\pm 3$ .



34\*. Arifmetik progressiya tashkil qiluvchi 3 ta musbat son yig'indisi 15 ga teng. Agar uning hadlariga mos ravishda 1,4 va 19 sonlari qo'shilsa, geometrik progressiya tashkil qiluvchi sonlar hosil bo'ladi. Arifmetik progressiyaning ayirmasini toping.

A) 2;      B) 3;      C) 4;      D) 11;      E) 21.

35\*. To'g'ri burchakli parallelepiped chiziqli o'lchamlarining (eni, bo'yi, balandligi) uzunliklarini ifodalovchi sonlar geometrik progressiya tashkil qiladi. Agar parallelepiped hajmi  $216 \text{ m}^3$ , diagonal  $\sqrt{364}$  m bo'lsa, parallelepipedning chiziqli o'lchamlarini toping.

A)  $9 \times 6 \times 4$ ;      B)  $9 \times 8 \times 3$ ;      C)  $18 \times 6 \times 2$ ;  
D)  $27 \times 4 \times 2$ ;      E)  $12 \times 9 \times 2$  m.

KO'RSATKICHLI VA LOGARIFMIK FUNKSIYALAR

1-§. Ko'rsatkichli funksiya, uning xossalari va grafiği

Ko'rsatkichli funksiya deb  $y = a^x$  ko'rinishdagi funksiyaga aytiladi. bunda  $a$  — berilgan son,  $a > 0$ ,  $a \neq 1$ .

Ko'rsatkichli funksiyaning xossalari

1) Funksiyaning aniqlanish sohasi barcha haqiqiy sonlar to'plamidan iborat, ya'ni  $x \in R$ .

2) Funksiyaning qiymatlar to'plami barcha musbat sonlardan iborat.

3) Funksiya  $a > 1$  bo'lganda o'suvchi,  $0 < a < 1$  bo'lganda kamayuvchi (99-rasm).

4) Funksiya toq ham emas, juft ham emas.

5)  $y = a^x$  va  $y = \left(\frac{1}{a}\right)^x$  funksiyalar grafiqlari  $Oy$  o'qiga nisbatan o'zaro simmetrikdir.

6) Funksiya grafiği  $(0; 1)$  nuqtadan o'tadi va  $Ox$  o'qidan yuqorida joylashgan (99-rasm).

Ko'rsatkichli funksiya turli fizik jarayonlarni tavsiflashda qo'llaniladi. Masalan, radioaktiv yemirilish

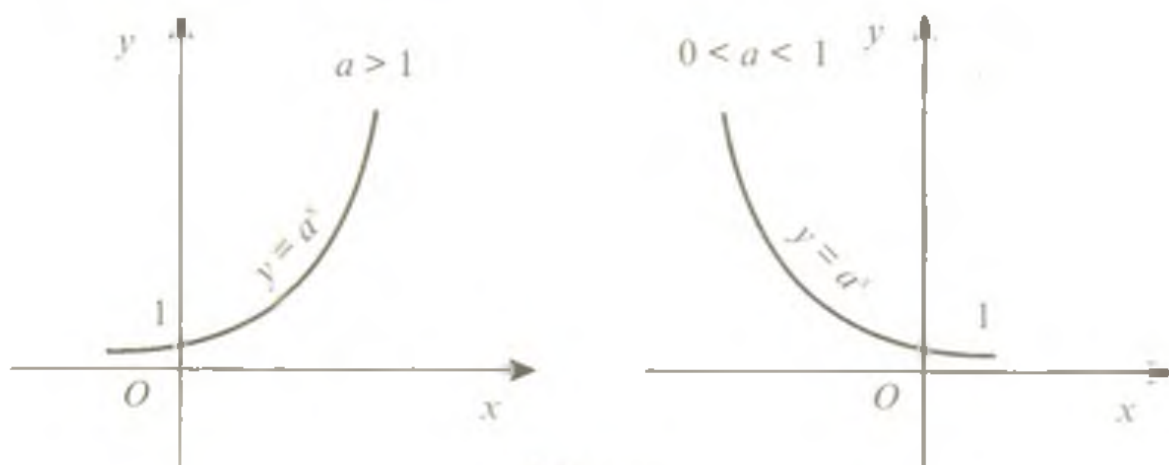

99-rasm

$$m(t) = m_0 \left(\frac{1}{2}\right)^{\frac{t}{T}}$$

formula bilan ifodalanadi, bunda  $m(t)$  — moddaning  $t$  vaqtdagi massasi,  $m_0$  — boshlang'ich  $t = 0$  vaqtdagi massasi,  $T$  — yarim yemirish davri (modda dastlabki miqdorining ikki marta kamayishigacha o'tgan vaqt oralig'i).

Shunga o'xshash, havo bosimining balandlikka bog'liq ravishda o'zgarishi, chulg'amga o'zgarmas kuchlanish ulangandagi o'zinduksiya toki va hokazolar ko'rsatkichli funksiya yordamida ifodalanadi.

## 2-§. Ko'rsatkichli tenglamalar

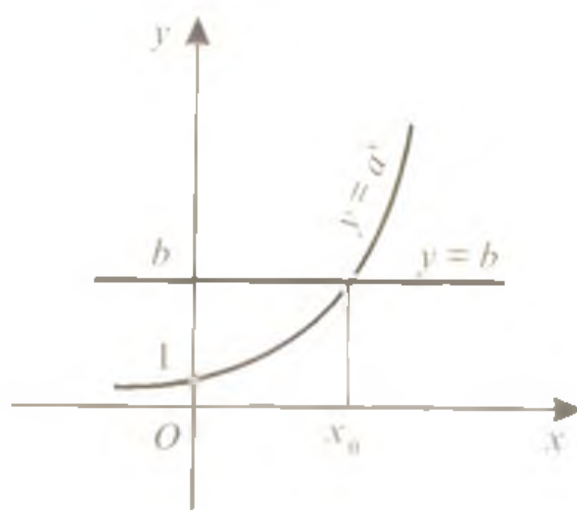

100-rasm

Noma'lum daraja ko'rsatkichida ishtirok etgan tenglama *ko'rsatkichli tenglama* deyiladi. Eng sodda ko'rsatkichli tenglamaga  $a^x = b$  (bunda ko'rsatkichli tenglama asosi  $a > 0$ ,  $a \neq 1$ ) tenglama misol bo'la oladi. Bunday tenglamani grafik usulda yechish mumkin (100-rasm).

Ushbu

$$a^{f(x)} = a^{\varphi(x)} \quad (\text{bunda } a > 0, a \neq 1)$$

tenglamaning yechilishi bu tenglamani  $f(x) = \varphi(x)$  tenglamaga

teng kuchli ekanligiga asoslanadi, ya'ni  $a^{f(x)} = a^{\varphi(x)} \Leftrightarrow f(x) = \varphi(x)$ .

**2.1. Ko'rsatkichli tenglamalarni yechish usullari. 1-usul. Umumiy asosga keltirish usuli.**

1-misol.  $3^{x^2-5x} = \sqrt[7]{9}$  tenglamani yeching.

$$\text{Yechilishi. } 3^{x^2-5x} = \sqrt[7]{9} \Leftrightarrow 3^{x^2-5x} = 3^{\frac{2}{7}} \Leftrightarrow x^2 - \frac{5}{7}x = \frac{2}{7} \Leftrightarrow$$

$$\Leftrightarrow 7x^2 - 5x - 2 = 0 \Rightarrow x_{1,2} = \frac{5 \pm 9}{14} \Rightarrow \begin{cases} x_1 = -\frac{2}{7}, \\ x_2 = 1. \end{cases}$$

Javob:  $\{-\frac{2}{7}; 1\}$ .

2-misol.  $5^{(x-1)(x+4)} = 1$  tenglamani yeching.

Yechilishi.  $5^{(x-1)(x+4)} = 1 \Leftrightarrow 5^{(x-1)(x+4)} = 5^0 \Leftrightarrow (x-1)(x+4) = 0 \Rightarrow$

$$\Rightarrow \begin{cases} x_1 = -4, \\ x_2 = 1. \end{cases}$$

Javob:  $\{-4; 1\}$ .

**2-usul.** Ko'paytuvchilarga ajratish usuli.

3-misol.  $5^x + 3 \cdot 5^{x-2} = 140$  tenglamani yeching.

Yechilishi.  $5^x + 3 \cdot 5^{x-2} = 140 \Leftrightarrow 5^x \left(1 + \frac{3}{25}\right) = 140 \Leftrightarrow$

$$\Leftrightarrow 5^x \cdot \frac{28}{25} = 140 \Leftrightarrow 5^x = \frac{140 \cdot 25}{28} \Leftrightarrow 5^x = 5^3 \Rightarrow [x = 3.$$

Javob: 3.

4-misol.  $3^{4x+5} - 2^{4x+7} - 3^{4x+3} - 2^{4x+4} = 0$  tenglamani yeching.

$$\begin{aligned} \text{Yechilishi. } 3^{4x+5} - 2^{4x+7} - 3^{4x+3} - 2^{4x+4} = 0 &\Leftrightarrow 3^{4x+3} \cdot (3^2 - 1) = \\ &= 2^{4x+3} \cdot (2^4 + 2) \Leftrightarrow 3^{4x+3} \cdot 8 = 2^{4x+3} \cdot 18 \Leftrightarrow \left(\frac{3}{2}\right)^{4x+3} = \left(\frac{3}{2}\right)^2 \Leftrightarrow 4x+3 = 2 \Rightarrow \end{aligned}$$

$$\Rightarrow [x = -\frac{1}{4}.$$

Javob:  $-\frac{1}{4}$ .

**3-usul.** Kvadrat tenglamaga keltirish usuli. Ushbu

$$Aa^{2x} + Ba^x + C = 0$$

ko'rinisdagi tenglama (bunda  $A, B, C$  — haqiqiy sonlar)  $a^x = t$  almashtirish orqali kvadrat tenglamaga keltiriladi.

5-misol.  $5^{2x} - 6 \cdot 5^x + 5 = 0$  tenglamani yeching.

Yechilishi.  $5^x = t$  almashtirishni kiritamiz. U holda

$$t^2 - 6t + 5 = 0 \Rightarrow \begin{cases} t_1 = 1, \\ t_2 = 5. \end{cases}$$

Qabul qilingan almashtirishni hisobga olsak,

$$5^x = 1 \Rightarrow [x_1 = 0,$$

$$5^x = 5 \Rightarrow [x_2 = 1.$$

Javob:  $\{0; 1\}$ .

6-misol.  $4^x + 2^{x+1} = 80$  tenglamani yeching.

Yechilishi.  $4^x + 2^{x+1} = 80 \Leftrightarrow 2^{2x} + 2 \cdot 2^x - 80 = 0$ .  $2^x = t$  almashtirishni kiritamiz. U holda

$$t^2 + 2t - 80 = 0 \Rightarrow t_{1,2} = -1 \pm \sqrt{1 + 80} \Rightarrow \begin{cases} t_1 = -10, \\ t_2 = 8. \end{cases}$$

Qabul qilingan almashtirishni inobatga olib, ushbu tenglamalarga ega bo'lamiz:

$2^x = -10$ , bu tenglama ko'rsatkichli funksiya o'zining aniqlanish sohasida musbat funksiya bo'lganligi sababli yechimga ega emas.

$$2^x = 8 \Leftrightarrow 2^x = 2^3 \Rightarrow [x = 3.$$

Javob: 3.

Ushbu

$$Aa^{2x} + B(ab)^x + Cb^{2x} = 0$$

ko'rinishdagi tenglama ham kvadrat tenglamaga keltiriladi. Buning uchun tenglamaning har ikkala tomoni  $b^{2x}$  ga bo'lib, tegishli almashtirish bajariladi:

$$Aa^{2x} + B(ab)^x + Cb^{2x} = 0 \Leftrightarrow A\left(\frac{a}{b}\right)^{2x} + B\left(\frac{a}{b}\right)^x + C = 0 \Leftrightarrow \left[\left(\frac{a}{b}\right)^x = t\right] \Leftrightarrow \\ \Leftrightarrow At^2 + Bt + C = 0.$$

7-misol.  $9^x + 6^x - 2 \cdot 4^x = 0$  tenglamani yeching.

$$\text{Yechilishi. } 9^x + 6^x - 2 \cdot 4^x = 0 \Leftrightarrow 3^{2x} + 3^x \cdot 2^x - 2 \cdot 2^{2x} = 0 \Leftrightarrow$$

$$\Leftrightarrow \left(\frac{3}{2}\right)^{2x} + \left(\frac{3}{2}\right)^x - 2 = 0 \Leftrightarrow \left[\left(\frac{3}{2}\right)^x = t\right] \Leftrightarrow t^2 + t - 2 = 0 \Rightarrow \begin{cases} t_1 = -2, \\ t_2 = 1. \end{cases}$$

Bajarilgan almashtirishni hisobga olsak, quyidagi tenglamalarga ega bo'lamiz:

1)  $\left(\frac{3}{2}\right)^x = -2$ , bu tenglama yechimga ega emas.

$$2) \left(\frac{3}{2}\right)^x = 1 \Leftrightarrow \left(\frac{3}{2}\right)^x = \left(\frac{3}{2}\right)^0 \Rightarrow [x = 0.$$

Javob: 0.

**4-usul.** Asosi ham, daraja ko'rsatkichi ham noma'lumga bog'liq bo'lgan funksiya ishtirok etgan ko'rsatkichli tenglamalarni yechish usuli.

Ushbu  $f(x)^{p(x)} = f(x)^{q(x)}$  ko'rinishdagi tenglamalarni yechishda quyidagi uchta hol ko'riladi:

1)  $f(x) = 1$ ; 2)  $f(x) = 0$ ; 3)  $f(x) \neq 1, f(x) \neq 0, \varphi(x) = g(x)$ .

Bu tenglamalarning yechimlari berilgan tenglamani to'g'ri tenglikka aylantirishi tekshirib ko'rilgach, tegishli ildizlari topiladi.

8-misol.  $(x+3)^{x-3} = (x+3)^{2x}$ .

Yechilishi. 1)  $x+3 = 1 \Rightarrow [x = -2$ ;

Tekshirish:  $(-2+3)^{-2-3} = (-2+3)^{-4} \Rightarrow 1^{-1} = 1^{-4}$  — to'g'ri tenglik. Demak,  $x = -2$  tenglama ildizi.

2)  $x+3 = 0 \Rightarrow [x = -3$ ;

Tekshirish:  $(-3+3)^{-3-3} = (-3+3)^{-6} \Rightarrow 0^0 = 0^{-6}$  — bu tenglikning o'ng tomoni ma'noga ega emas, shu sababli  $x = -3$  berilgan tenglamaning ildizi emas.

3) Daraja ko'rsatkichlarini tenglashtiramiz:

$$x^2 - 3 = 2x \Leftrightarrow x^2 - 2x - 3 = 0 \Rightarrow \begin{cases} x_1 = 3, \\ x_2 = -1. \end{cases}$$

Tekshirish:  $(3+3)^{2-3} = (3+3)^{-1} \Rightarrow 6^{-1} = 6^{-1}$ ,  $(-1+3)^{1-3} = (-1+3)^{-2} \Rightarrow 2^{-2} = 2^{-2}$ . Bular to'g'ri tengliklardir. Shuning uchun  $x = 3$  va  $x = -1$  tenglama ildizlari bo'ladi.

Javob:  $\{-2; -1; 3\}$ .

**5-usul. Grafik usul.** Bu usul tenglama ildizlarini yuqorida bayon qilingan analitik usullari bilan aniq topish imkoni bo'lmagan hollarda qo'llaniladi.

9-misol.  $\left(\frac{1}{2}\right)^x = x - \frac{1}{2}$  tenglamani yeching.

Yechilishi.  $y = \left(\frac{1}{2}\right)^x$  va

$y = x - \frac{1}{2}$  funksiyalarning grafiklarini bir chizmada tasvirlaymiz (101-rasm).

Rasmdan bu funksiyaning grafiklari abssissasi  $x = 1$  nuqtada kesishishi ko'rinib turibdi.

Haqiqatan ham,  $x = 1$  da

$$\left(\frac{1}{2}\right)^1 = 1 - \frac{1}{2} \Rightarrow \frac{1}{2} = \frac{1}{2}$$

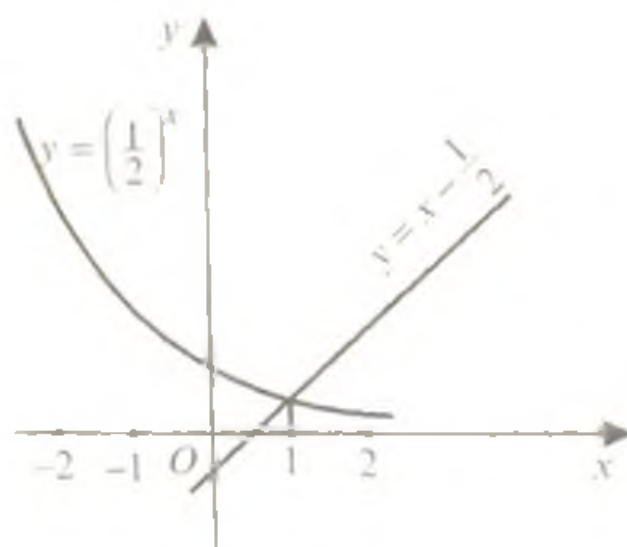

101-rasm

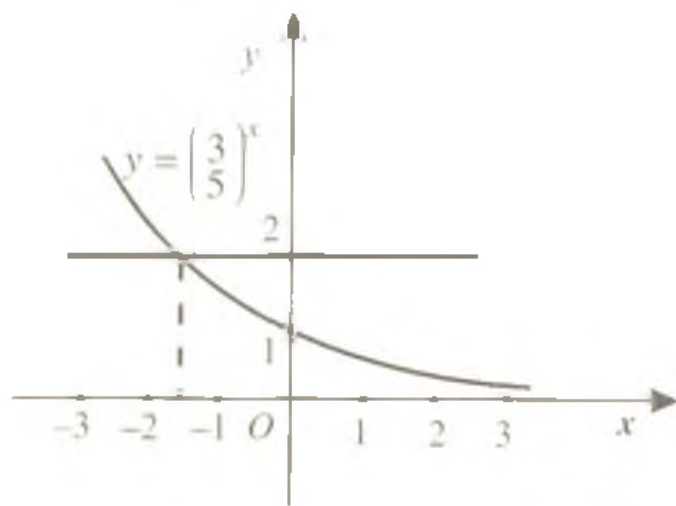

102-rasm

to'g'ri tenglik hosil bo'ldi. Demak,  $x = 1$  tenglama ildizi.

Tenglamaning boshqa ildizlari yo'q ekanini ko'rsatamiz.  $y = \left(\frac{1}{2}\right)^x$  kamayuvchi funksiya,  $y = x - \frac{1}{2}$  esa o'suvchi funksiya. Shu sababli  $x > 1$  da  $y = \left(\frac{1}{2}\right)^x$  funk-

siyaning qiymatlari  $\frac{1}{2}$  dan kichik,  $y = x - \frac{1}{2}$  funksiyaning qiymatlari esa  $\frac{1}{2}$  dan katta;  $x < 1$  da, aksincha, birinchi funksiyaning qiymatlari  $\frac{1}{2}$  dan katta, ikkinchisining qiymatlari esa  $\frac{1}{2}$  dan kichik. Shu sababli, bu funksiyalarning grafiklari absissasi  $x = 1$  dan boshqa kesishish nuqtalariga ega bo'lmaydi.

Javob:  $x = 1$ .

10-misol.  $\left(\frac{3}{5}\right)^x = 2$  tenglamaning ildizi  $(-\infty; -2)$ ,  $(-2; -1)$ ,  $(-1; 1)$  oraliqlardan qaysi biriga tegishli?

Yechilishi. Bu masalani yechishda ham grafik usuldan foydalanamiz. 102-rasmda  $y = \left(\frac{3}{5}\right)^x$  va  $y = 2$  funksiyalarning grafiklari tasvirlangan. Bu funksiyalar grafiklari kesishish nuqtasining absissasi  $x \approx -1.35$  ko'rsatilgan oraliqlardan ikkinchisiga —  $(-2; -1)$  ga tegishli ekanligi ko'rinib turibdi.

Javob:  $(-2; -1)$ .

**2.2. Ko'rsatkichli tenglamalar sistemalari.** Ko'rsatkichli tenglamalar ishtirok etgan tenglamalar sistemalarini yechishda ham algebraik tenglamalar sistemalarini yechishdagi ma'lum usullar ishlatiladi.

11-misol. 
$$\begin{cases} 2^x 3^y = 24, \\ 2^y 3^x = 54 \end{cases}$$
 tenglamalar sistemasini yeching.

$$\text{Yechilishi. } \begin{cases} 2^x 3^y = 24, \\ 2^x 3^y = 54 \end{cases} \Leftrightarrow \begin{cases} 2^x 3^y = 2^3 \cdot 3, \\ 2^x 3^y = 2 \cdot 3^3 \end{cases} \quad (1)$$

bu ikki tenglamalarning o'ng va chap tomonlarini ko'paytiramiz. U holda

$$2^{x+y} \cdot 3^{x+y} = 2^4 \cdot 3^4 \Leftrightarrow 6^{x+y} = 6^4 \Leftrightarrow x + y = 4 \quad (2)$$

tenglama hosil bo'ladi. Endi (1) tenglamalar sistemasining o'ng va chap tomonlarini hadma-had bo'lib,  $x - y = 2$  tenglamani hosil qilamiz. Shunday qilib, berilgan tenglamaga teng kuchli

$$\begin{cases} x + y = 4, \\ x - y = 2 \end{cases}$$

tenglamalar sistemasiga ega bo'ldik. Bu sistemani yechamiz:

$$\begin{cases} x + y = 4, \\ x - y = 2 \end{cases} \Leftrightarrow \begin{cases} 2x = 6, \\ y = x - 2 \end{cases} \Leftrightarrow \begin{cases} x = 3, \\ y = 1. \end{cases}$$

Javob: (3; 1).

$$12\text{-misol. } \begin{cases} (x-y) \cdot 0,5^{x-y} = 5 \cdot 2^{x-y}, \\ \frac{x+y}{(x-y)^7} = 125 \end{cases} \quad \text{tenglamalar sistemasini}$$

yeching.

$$\text{Yechilishi. } \begin{cases} (x-y) \cdot 0,5^{x-y} = 5 \cdot 2^{x-y}, \\ \frac{x+y}{(x-y)^7} = 125 \end{cases} \Leftrightarrow \begin{cases} (x-y) \cdot 2^{x-y} = 5 \cdot 2^{x-y}, \\ \frac{x+y}{(x-y)^7} = 5^3 \end{cases} \Leftrightarrow$$

$$\Leftrightarrow \begin{cases} x - y = 5, \\ \frac{x+y}{5^7} = 5^3 \end{cases} \Leftrightarrow \begin{cases} x - y = 5, \\ x + y = 21 \end{cases} \Leftrightarrow \begin{cases} 2x = 26, \\ y = 21 - x \end{cases} \Leftrightarrow \begin{cases} x = 13, \\ y = 8. \end{cases}$$

Javob: (13; 8).

### 3-§. Ko'rsatkichli tengsizliklar

**3.1. Ko'rsatkichli tengsizliklarni yechish usullari.** Noma'lum daraja ko'rsatkichda ishtirok etgan tengsizlik *ko'rsatkichli tengsizlik* deyiladi.



$a^{f(x)} > a^{\varphi(x)}$  ( $a^{f(x)} < a^{\varphi(x)}$ ) ko'rinishdagi tengsizliklarni yechishda  $y = a^x$  ko'rsatkichli funksiya  $a > 1$  da o'suvchi,  $0 < a < 1$  da kamayuvchi ekanligi e'tiborga olinadi. Demak, agar  $a > 1$  bo'lsa,

$$a^{f(x)} > a^{\varphi(x)} \Leftrightarrow f(x) > \varphi(x) \quad (a^{f(x)} < a^{\varphi(x)} \Leftrightarrow f(x) < \varphi(x));$$

agar  $0 < a < 1$  bo'lsa,

$$a^{f(x)} > a^{\varphi(x)} \Leftrightarrow f(x) < \varphi(x) \quad (a^{f(x)} < a^{\varphi(x)} \Leftrightarrow f(x) > \varphi(x)).$$

Agar ko'rsatkichli tengsizlikda asos ham o'zgaruvchiga bog'liq bo'lsa,

$$f(x)^{\varphi(x)} > 1 \quad (f(x)^{\varphi(x)} < 1), \quad f(x)^{\varphi(x)} > f(x)^{g(x)} \quad (f(x)^{\varphi(x)} < f(x)^{g(x)})$$

kabi tengsizliklarni yechishda  $f(x) > 1$  va  $0 < f(x) < 1$  bo'lgan hollar qaralishi kerak:

$$f(x)^{\varphi(x)} > 1 \Leftrightarrow \begin{cases} | f(x) > 1, \\ | \varphi(x) > 0, \\ | 0 < f(x) < 1, \\ | \varphi(x) < 0. \end{cases}$$

$$f(x)^{\varphi(x)} > f(x)^{g(x)} \Leftrightarrow \begin{cases} | f(x) > 1, \\ | \varphi(x) > g(x), \\ | 0 < f(x) < 1, \\ | \varphi(x) < g(x). \end{cases}$$

### 3.2. Ko'rsatkichli tengsizliklarni yechishga doir misollar.

1-misol.  $2^{3x+7} < 2^{2x-1}$  tengsizlikni yeching.

Yechilishi: berilgan tengsizlikda daraja asosi 1 dan katta, shuning uchun ko'rsatkichlarni taqqoslab, o'sha ma'noli tengsizlikka o'tamiz:  $2^{3x+7} < 2^{2x-1} \Leftrightarrow 3x+7 < 2x-1 \Rightarrow [x < -8$ .

Javob:  $(-\infty; -8)$ .

2-misol.  $(0,04)^{5x-x^2-8} \leq 625$  tengsizlikni yeching.

Yechilishi: berilgan tengsizlikning ikkala qismini umumiy asosga keltiramiz.

$$(0,04)^{5x-x^2-8} \leq 625 \Leftrightarrow (0,04)^{5x-x^2-8} \leq \left(\frac{1}{25}\right)^{-2} \Leftrightarrow (0,04)^{5x-x^2-8} \leq (0,04)^{-2}.$$

$0 < (0,04) < 1$  bo'lgani uchun ko'rsatkichlarni taqqoslab, qarama-qarshi ma'noli tengsizlikka ega bo'lamiz. Uni yechib, tengsizlik yechimini topamiz:

$$(0,04)^{5x-x^2-8} \leq (0,04)^{-2} \Leftrightarrow 5x-x^2-8 \geq -2 \Leftrightarrow x^2-5x+6 \leq 0 \Leftrightarrow \\ \Leftrightarrow (x-2)(x-3) \leq 0 \Rightarrow [2 \leq x \leq 3].$$

Javob:  $[2; 3]$ .

3-misol.  $4^x - 6 \cdot 2^x + 8 \leq 0$  tengsizlik nechta butun yechimga ega?

Yechilishi:  $t = 2^x$  belgilash orqali yordamchi noma'lum kiritish natijasida ushbu

$$t^2 - 6t + 8 \leq 0 \Leftrightarrow (t-2)(t-4) \leq 0$$

tengsizlikni hosil qilamiz.  $x$  o'zgaruvchiga o'tib,

$$2 \leq 2^x \leq 2^2$$

qo'sh tengsizlikka ega bo'lamiz. Bundan

$$1 \leq x \leq 2.$$

Bu kesmaga tegishli butun sonlar faqat 1 va 2.

Javob: 2 ta.

4-misol.  $0,4^{x^2} \cdot 0,5^{x^2} > (0,2^x)^4$  tengsizlikning eng kichik butun yechimini toping.

$$\text{Yechilishi: } 0,4^{x^2} \cdot 0,5^{x^2} > (0,2^x)^4 \Leftrightarrow (0,4 \cdot 0,5)^{x^2} > 0,2^{4x} \Leftrightarrow \\ \Leftrightarrow 0,2^{x^2} > 0,2^{4x} \Leftrightarrow x^2 < 4x \Rightarrow x(x-4) < 0 \Rightarrow ](0; 4) .$$

Bu oraliqdagi eng kichik butun son 1 ga teng.

Javob: 1.

5-misol.  $(\cos 60^\circ)^{x^2-6x+9} < 1$  tengsizlikni yeching.

Yechilishi.  $\cos 60^\circ = 0,5$ ,  $1 = (0,5)^0$  ekanligidan berilgan tengsizlik ushbu

$$x^2 - 6x + 9 > 0$$

tengsizlikka teng kuchli. Demak,

$$(x-3)^2 > 0 \Rightarrow [x \neq 3].$$

Javob:  $(-\infty; 3) \cup (3; +\infty)$ .

6-misol.  $|x|^{x^2-x-2} < 1$  tengsizlikni yeching.

Yechilishi. Bu tengsizlikni yechishda ikki hol qaraladi:  $|x| > 1$  va  $|x| < 1$ . Birinchi holda daraja ko'rsatkichi  $x^2 - x - 2$  manfiy, ikkinchi holda esa musbat bo'lishi kerak. Shunday qilib, berilgan tengsizlik quyidagi ikki sistema birlashmasini yechilishiga keltiriladi:

$$1) \begin{cases} |x| > 1, \\ x^2 - x - 2 < 0. \end{cases} \quad 2) \begin{cases} |x| < 1, \\ x^2 - x - 2 > 0. \end{cases}$$

Birinchi sistemani yechamiz:

$$\begin{cases} |x| > 1, \\ x^2 - x - 2 < 0 \end{cases} \Leftrightarrow \begin{cases} x < -1, \\ x > 1, \\ (x-2)(x+1) < 0 \end{cases} \Rightarrow [x \in (1; 2)] \quad (103-$$

rasm).

Ikkinchi sistemani yechamiz:

$$\begin{cases} x < 1, \\ x^2 - x - 2 > 0 \end{cases} \Leftrightarrow \begin{cases} -1 < x < 1, \\ (x-2)(x+1) > 0 \end{cases} \Rightarrow [x \in \emptyset]. \quad (104\text{-rasm}).$$

Javob: (1;2)



103-rasm



104-rasm

## 4-§. Logarifmlar

**4.1. Sonning logarifmi.** Biz bilamizki,  $a^x = b$  ko'rinishdagi tenglamani yechishning asosiy usuli uning chap va o'ng qismlarini ayni bir asosli daraja ko'rinishida ifodalay olishdan iborat. Lekin buning har doim ham iloji bo'lavermaydi, masalan  $3^x = 25$ ,  $2^x = 5$ ,  $6^x = 10$  va hokazo. Biroq bunday tenglamalar ildizga ega ekanligini bilamiz. Bunday tenglamalarni yechish uchun **sonning logarifmi** tushunchasi kiritiladi. Shu bobning 2-§ ida  $a^x = b$  (bunda  $a > 0$ ,  $a \neq 1$ ) tenglama birgina ildizga ega ekanligi va u grafik usulda yechilishi mumkinligi aytilgan edi. Bu ildiz  $b$  sonning  $a$  asosga ko'ra logarifmi, deb ataladi va  $\log_a b$  kabi belgilanadi (100-rasmda  $\log_a b = x_0$ ).

Ta'rif:  $b$  musbat sonning  $a$  asosga ko'ra ( $a > 0$ ,  $a \neq 1$ ) logarifmi deb  $b$  sonni hosil qilish uchun  $a$  sonni ko'tarish kerak bo'lgan daraja ko'rsatkichiga aytiladi.

Masalan,  $\log_2 16 = 4$ , chunki  $2^4 = 16$ ;  $\log_{\frac{1}{2}} 8 = -3$ , chunki

$\left(\frac{1}{2}\right)^{-3} = 8$ ;  $\log_3 81 = 4$ , chunki  $3^4 = 81$ ;  $\log_4 1 = 0$ , chunki  $4^0 = 1$ ;

$\log_5 5 = 1$ , chunki  $5^1 = 5$ ;

Logarifmning ta'rifini

$$a^{\log_a b} = b \quad (1)$$

tenglik bilan yozish mumkin. Bu tenglik  $b > 0$ ,  $a > 0$ ,  $a \neq 1$  bo'lganda o'rinli bo'lib, *asosiy logarifmik ayniyat* deb ataladi.

Sonning logarifmini topish amali *logarifmlash amali* deb ataladi.

Sonning logarifmini topishga doir bir necha misollar keltiramiz.

1-misol.  $\log_3 \frac{1}{729}$  ni hisoblang.

Yechilishi. Logarifmning ta'rifiga ko'ra  $\log_3 \frac{1}{729}$  daraja ko'rsatkichi bo'lganligi uchun shu daraja ko'rsatkichini  $x$  deb belgilaymiz:

$$\log_3 \frac{1}{729} = x.$$

U holda ta'rifga ko'ra

$$3^x = \frac{1}{729}.$$

Hosil bo'lgan ko'rsatkichli tenglamani yechamiz:

$$3^x = \frac{1}{729} \Leftrightarrow 3^x = 3^{-6} \Rightarrow [x = -6.$$

Shunday qilib,  $\log_3 \frac{1}{729} = -6$

Javob:  $-6$ .

2-misol.  $\log_{\frac{1}{4}\sqrt[3]{4}} 256$  ni hisoblang.

Yechilishi.  $\log_{\frac{1}{4}\sqrt[3]{4}} 256 = x$  belgilash kiritamiz. U holda ta'rifga ko'ra

$$\left(\frac{1}{4}\sqrt[3]{4}\right)^x = 256 \Leftrightarrow \left(4^{-1} \cdot 4^{\frac{1}{3}}\right)^x = 4^4 \Leftrightarrow \left(4^{\frac{1}{3}-1}\right)^x = 4^4 \Leftrightarrow 4^{-\frac{2}{3}x} = 4^4 \Leftrightarrow$$

$$\Leftrightarrow -\frac{2}{3}x = 4 \Rightarrow [x = -6.$$

Demak,  $\log_{\frac{1}{4}\sqrt[3]{4}} 256 = -6$ .

Javob:  $-6$ .

3-misol.  $\left(\frac{1}{4}\right)^{2+2\log\frac{1}{4}}$  ni hisoblang.

Yechilishi. Berilgan logarifmik ifodani hisoblashda asosiy logarifmik ayniyat (1) dan foydalanamiz:

$$\left(\frac{1}{4}\right)^{2+2\log\frac{1}{4}} = \left(\frac{1}{4}\right)^2 \cdot \left(\frac{1}{4}\right)^{2\log\frac{1}{4}} = \frac{1}{16} \left( \left(\frac{1}{4}\right)^{\log\frac{1}{4}} \right)^2 = \frac{1}{16} \cdot 6^2 = \frac{36}{16} = 2\frac{1}{4}$$

Javob:  $2\frac{1}{4}$ .

**4.2. Logarifmning xossalari.** Logarifmlar ishtirok etgan ifodalardagi almashtirishlarda, hisoblashlarda, tenglama va tengsizliklarni yechishda logarifmlarning turli xossalardan foydalaniladi. Shu xossalarning asosiylarini keltiramiz.

1. *Faqat musbat sonlarning logarifmi mavjud, ya'ni  $\log_a N$  (bunda  $a > 0, a \neq 1, N > 0$ ) bo'lsagina mavjud.*

2. *Asos  $a > 1$  bo'lsa,  $N > 1$  sonlarning logarifmlari musbat,  $0 < N < 1$  sonlarning logarifmlari manfiy. Masalan,  $\log_2 6 > 0$ ,*

$$\log_2 \frac{1}{5} < 0.$$

3. *Asos  $0 < a < 1$  bo'lsa,  $N > 1$  sonlarning logarifmlari manfiy,  $0 < N < 1$  sonlarning logarifmlari esa musbat. Masalan,  $\log_{\frac{1}{3}} 6 < 0$ ,*

$$\log_{\frac{1}{4}} \frac{1}{5} > 0.$$

4. *Agar  $a > 1$  bo'lsa, katta songa katta logarifm mos keladi, ya'ni  $N_1 > N_2$  bo'lsa,  $\log_a N_1 > \log_a N_2$ . Masalan,  $\log_5 10 > \log_5 8$ .*

5. *Agar  $0 < a < 1$  bo'lsa, katta songa kichik logarifm mos keladi, ya'ni  $N_1 > N_2$  bo'lsa,  $\log_a N_1 < \log_a N_2$ . Masalan,  $\log_{\frac{1}{3}} 12 < \log_{\frac{1}{3}} 8$ .*

6. *Har qanday asosga ko'ra ( $a > 0, a \neq 1$ ) 1 ning logarifmi nolga teng, ya'ni  $\log_a 1 = 0$ .*

7. Asosning logarifmi birga teng, ya'ni  $\log_a a = 1$ .

8. Ikki sonning bir xil asosli logarifmlari teng bo'lsa, shu sonlarning o'zlarini ham teng bo'ladi. Ya'ni,  $\log_a M = \log_a N$  tenglikdan  $M = N$  tenglik kelib chiqadi. Bunda  $a > 0$ ,  $a \neq 1$ ;  $M > 0$ ,  $N > 0$ .

#### 4.3. Ko'paytmaning, bo'linmaning va darajaning logarifmi.

1-teorema. *Ikki musbat son ko'paytmasining logarifmi shu sonlar logarifmlarining yig'indisiga teng, ya'ni*

$$\log_a (N_1 \cdot N_2) = \log_a N_1 + \log_a N_2 \quad (a > 0; a \neq 1). \quad (2)$$

Masalan.  $\log_3 18 = \log_3 (9 \cdot 2) = \log_3 9 + \log_3 2 = 3 + \log_3 2$ .

Bu teorema faqat ikkita ko'paytuvchi uchungina o'rinli bo'lmay, balki istalgan sondagi ko'paytuvchilar uchun ham o'rinlidir:

$$\log_a (N_1 \cdot N_2 \cdot N_3 \cdot \dots \cdot N_k) = \log_a N_1 + \log_a N_2 + \log_a N_3 + \dots + \log_a N_k,$$

bunda  $N_i > 0$  ( $i = \overline{1; k}$ ). ( $a > 0; a \neq 1$ ).

Masalan.  $\log_2 (2 \cdot 5 \cdot 9 \cdot 16) = \log_2 2 + \log_2 5 + \log_2 9 + \log_2 16 = 1 + \log_2 5 + \log_2 9 + 4 = 5 + \log_2 5 + \log_2 9$ .

2-teorema. *Ikki musbat son bo'linmasining logarifmi bo'linuvchi va bo'luvchi logarifmlarining ayirmasiga teng, ya'ni*

$$\log_a \frac{N_1}{N_2} = \log_a N_1 - \log_a N_2, \quad (3)$$

bunda  $a > 0$ ,  $a \neq 1$ ,  $N_1 > 0$ ,  $N_2 > 0$ .

Masalan.  $\log_3 \frac{32}{15} = \log_3 32 - \log_3 15 = \log_3 32 - \log_3 3 \cdot 5 = \log_3 32 - \log_3 5 - 1$ .

3-teorema. *Musbat son darajasining logarifmi shu daraja ko'rsatkichining uning asosi logarifmi bilan ko'paytmasiga teng, ya'ni*

$$\log_a N^k = k \log_a N, \quad (4)$$

bunda  $a > 0$ ,  $a \neq 1$ ,  $N > 0$ .

Masalan.  $\log_5 625 = \log_5 5^4 = 4 \log_5 5 = 4$ .

4.4. O'nli va natural logarifmlar. Sonning o'nli logarifmi deb shu sonning 10 asosga ko'ra logarifmiga aytiladi va  $\log_{10} N$  o'rniga  $\lg N$  yoziladi ( $N > 0$ ).

Sonning *natural logarifmi* deb shu sonning  $e$  asosga ko'ra logarifmiga aytiladi, bu yerda  $e$  — irratsional son bo'lib, uning taqribiy qiymati 2,7 ga teng. Bunda  $\log_e N$  o'rniga  $\ln N$  yoziladi ( $N > 0$ ). O'nli va natural logarifmlar uchun ham  $a$  ( $a > 0, a \neq 1$ ) istalgan asosli logarifmlarning xossalari o'rinlidir. Masalan,  $\lg 10 = 1$ ,

$$\lg 1 = 0, \lg 0,1 = -1, \lg \sqrt{10} = \lg 10^{\frac{1}{2}} = \frac{1}{2} \lg 10 = \frac{1}{2}, \lg 2000 = \lg 2 \cdot 10^3 = \lg 2 + \lg 10^3 = \lg 2 + 3.$$

$$\ln 1 = 0, \ln e = 1, \ln e^3 = 3 \ln e = 3, \ln 100 \cdot e = \ln(10^2 \cdot e) = 2 \ln 10 + \ln e = 2 \ln 10 + 1.$$

**4.5. Logarifmning yangi asosiga o'tish formulasi.** Yangi asosga o'tishning ushbu

$$\log_a N = \frac{\log_b N}{\log_b a} \quad (5)$$

formulasi o'rinlidir. Bunda  $a > 0, a \neq 1, b > 0, b \neq 1, N > 0$ .

(5) formulani isbotlash uchun asosiy ayniyat (1) dan foydalanamiz:

$$a^{\log_a N} = N.$$

Agar musbat sonlar teng bo'lsa, ularning bir xil asosli logarifmlari ham teng bo'lishi ravshan. Shu sababli

$$\log_b (a^{\log_a N}) = \log_b N.$$

3-teoremaga ko'ra bu tenglikni

$$\log_a N \cdot \log_b a = \log_b N$$

shaklda yozish mumkin. Bundan

$$\log_a N = \frac{\log_b N}{\log_b a}$$

(5) formula kelib chiqadi.

Agar (5) formulada  $b$  sifatida  $N$  olinsa,

$$\log_a N = \frac{1}{\log_N a} \quad (6)$$

tenglikni hosil qilamiz.

Logarifmik ifodalarni soddalashtirishda keng qo'llaniladigan ushbu tengliklar ham o'rinli ekanligini eslatib o'tamiz:

$$\log_a^k N^m = m^k \log_a^k N, \quad (7)$$

$$\log_{a^k} N^m = \frac{m}{k} \log_a N, \quad (8)$$

$$M^{\log_a N} = N^{\log_a M}. \quad (9)$$

(7), (8) formulalarda  $a > 0$ ,  $a \neq 1$ ,  $N > 0$ ,  $k$  va  $m$  ratsional sonlar.

(9) formulada  $M$  va  $N$  musbat va birga teng bo'lmagan sonlar.

Logarifmning xossalari tadbqiqiga doir bir necha misollar keltiramiz.

4-misol. Agar  $\log_3 2 = a$  bo'lsa,  $\log_3 18$  ni  $a$  orqali ifodalang.

Yechilishi.  $18 = 2 \cdot 3^2$  deb, 1, 3- teoremlardan foydalanamiz:

$$\log_3 18 = \log_3 (2 \cdot 3^2) = \log_3 2 + \log_3 3^2 = \log_3 2 + 2\log_3 3 = \log_3 2 + 2 = a + 2.$$

Javob:  $a + 2$ .

5-misol. Agar  $\lg 13 = a$ ,  $\lg 2 = b$  bo'lsa,  $\log_5 3.38$  ni toping.

Yechilishi.  $3.38 = \frac{13^2 \cdot 2}{100}$  ekanligini hisobga olib, 1, 2, 3-teoremlardan foydalanamiz va yangi asosga o'tish formulasi (5) ga ko'ra 10 li asosga o'tamiz:

$$\log_5 3.38 = \log_5 \frac{13^2 \cdot 2}{100} = \log_5 (13^2 \cdot 2) - \log_5 100 = \frac{\lg 13^2 + \lg 2}{\lg 5} -$$

$$\frac{\lg 100}{\lg 5} = \frac{2 \lg 13 + \lg 2 - 2}{\lg \frac{10}{2}} = \frac{2a + b - 2}{1 - \lg 2} = \frac{2a + b - 2}{1 - b}.$$

Javob:  $\frac{2a + b - 2}{1 - b}$ .

6-misol.  $\log_2 3 \cdot \log_3 4 \cdot \log_4 5 \cdot \dots \cdot \log_9 10$  ni soddalashtiring.

Yechilishi. Berilgan ifodadagi barcha logarifmlarda (5) formuladan foydalanib 2 asosga o'tamiz:

$$\begin{aligned} & \log_2 3 \cdot \log_3 4 \cdot \log_4 5 \cdot \dots \cdot \log_8 9 \cdot \log_9 10 = \\ & = \log_2 3 \cdot \frac{\log_2 4}{\log_2 3} \cdot \frac{\log_2 5}{\log_2 4} \cdot \dots \cdot \frac{\log_2 9}{\log_2 8} \cdot \frac{\log_2 10}{\log_2 9} = \log_2 10. \end{aligned}$$

Javob:  $\log_2 10$ .

### 5-§. Logarifmik funksiya, uning grafigi va xossalari

$y = a^x$  ( $a > 0$ ,  $a \neq 1$ ) ko'rsatkichli funksiya teskari funksiyasi mavjud bo'ladigan barcha xossalarga ega (VIII bob, 6-§): uning aniqlanish sohasi —  $(-\infty; +\infty)$ , qiymatlar to'plami —  $(0; +\infty)$ ,  $a > 1$



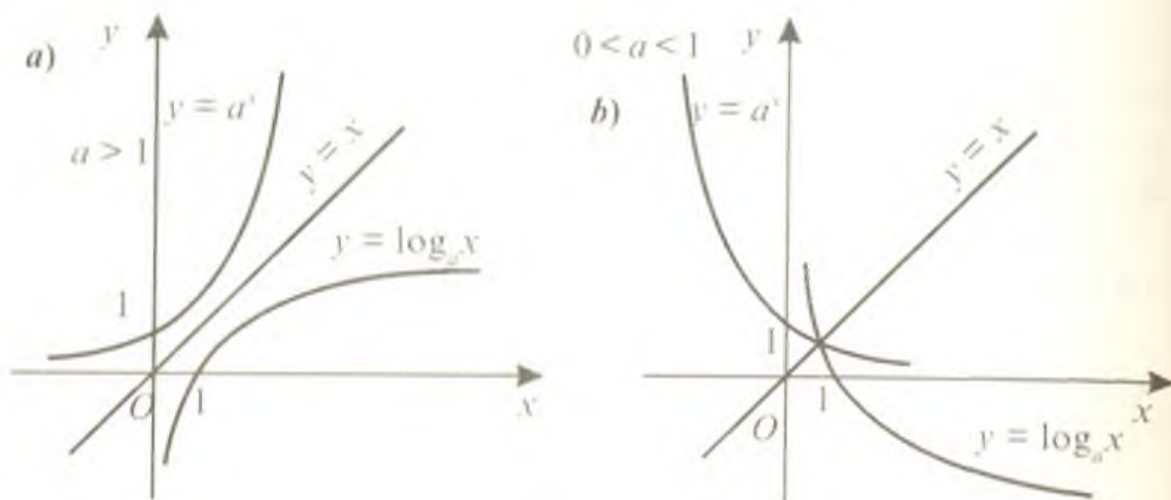

105-rasm

bo'lsa, o'sadi,  $0 < a < 1$  bo'lsa, kamayadi. Ko'rsatkichli funktsiyaning teskari funktsiyasini topish uchun

$$a^x = y$$

tenglamada  $x$  ni  $y$  orqali ifodasini topamiz:

$$x = \log_a y.$$

Hosil bo'lgan tenglikda  $x$  va  $y$  ning o'rinlarini almashtiramiz:

$$y = \log_a x,$$

bu yerda  $a > 0$ ,  $a \neq 1$ .

$y = \log_a x$  funktsiya *logarifmik funktsiya* deyiladi.

Shunday qilib, bir xil asosli ko'rsatkichli va logarifmik funktsiyalar o'zaro teskari funktsiyalardir. Shu sababli logarifmik funktsiya grafigini yasash uchun bir xil asosli ko'rsatkichli funktsiya grafigini yasab, bu grafikni  $y = x$  to'g'ri chiziqqa nisbatan simmetrik akslantirish kifoyadir. 105-a rasmda  $y = a^x$  va  $y = \log_a x$  funktsiyalar grafiglari  $a > 0$  uchun, 105-b rasmda  $0 < a < 1$  uchun tasvirlangan.

### Logarifmik funktsiyalarning xossalari

1) Funktsiyaning aniqlanish sohasi barcha musbat sonlar to'plamidan iborat, ya'ni  $x \in (0; +\infty)$ .

2) Funktsiyaning qiymatlar to'plami barcha haqiqiy sonlar to'plamidan iborat.

3)  $y = \log_a x$  funktsiya toq ham emas, juft ham emas.

4) Funktsiya o'zining aniqlanish sohasida  $a > 1$  bo'lsa, o'sadi,  $0 < a < 1$  bo'lsa, kamayadi.

5) Agar  $a > 1$  bo'lsa, o'zgaruvchi  $x$  nolga intilganda ( $x \rightarrow 0$  da)  $y = \log_a x$  funksiyaning qiymatlari cheksiz kamayadi ( $y \rightarrow -\infty$ ).

Agar  $0 < a < 1$  bo'lsa,  $x \rightarrow 0$  da  $y = \log_a x$  funksiyaning qiymatlari cheksiz o'sadi ( $y \rightarrow +\infty$ ).

1-misol.  $y = \log_3(x^2 + x - 2)$  funksiyaning aniqlanish sohasini toping.

Yechilishi. Faqat musbat sonlarning logarifmi mavjud bo'lgani uchun masalaning yechilishi

$$x^2 + x - 2 > 0$$

tengsizlikka keltiriladi. Uni yechamiz:

$$x^2 + x - 2 > 0 \Rightarrow (x + 2)(x - 1) > 0 \Rightarrow \begin{cases} x < -2, \\ x > 1. \end{cases}$$

Javob:  $x \in (-\infty; -2) \cup (1; +\infty)$ .

2-misol.  $y = \log_{\frac{1}{2}} x$  funksiyaning aniqlanish sohasini toping.

Yechilishi. Logarifm va modulning ta'riflariga asoslanib  $x \neq 0$  xulosaga kelamiz.

Javob:  $x \in (-\infty; 0) \cup (0; +\infty)$ .

3-misol.  $y = \lg \frac{x^2 + 4x}{x^2 - 5x + 6}$  funksiyaning aniqlanish sohasini toping.

Yechilishi. Masala logarifmik funksiyaning aniqlanish sohasi barcha musbat sonlar to'plamidan iborat bo'lganligi sababli

$$\frac{x^2 + 4x}{x^2 - 5x + 6} > 0$$

tengsizlikning yechilishiga keltiriladi. Bu tengsizlikni oraliqlar usuli bilan yechamiz:

$$\frac{x^2 + 4x}{x^2 - 5x + 6} > 0 \Leftrightarrow \frac{x(x + 4)}{(x - 3)(x - 2)} > 0.$$

106-rasmdan berilgan funksiyaning aniqlanish sohasi  $(-\infty; -4)$ ,  $(0; 2)$  va  $(3; +\infty)$  oraliqlar birlashmasidan iborat ekanligini topamiz.

Javob:  $x \in (-\infty; -4) \cup (0; 2) \cup (3; +\infty)$ .

4-misol.  $y = \lg(x^2 - 4x + 5)$  funksiyaning qiymatlar to'plamini toping.

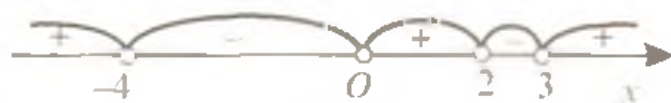

106-rasm

Yechilishi. 1-usul. Kvadrat uchhad  $(x^2 - 4x + 5)$  da to'la kvadratni ajratamiz:

$$x^2 - 4x + 5 = (x - 2)^2 + 1.$$

Demak, bu kvadrat uchhadning qiymatlari 1 va undan katta bo'lgan sonlardan iborat. Shu sababli  $y = \lg(x^2 - 4x + 5)$  funksiyaning qiymatlari to'plami nol va undan katta barcha sonlar to'plamidan iborat bo'ladi.

2-usul. VIII bobda ko'rsatilganidek,

$$y = \lg(x^2 - 4x + 5) = a$$

tenglama yechimga ega bo'ladigan  $a$  ning barcha qiymatlari to'plamini topamiz:

$$\lg(x^2 - 4x + 5) = a \Leftrightarrow x^2 - 4x + 5 = 10^a \Leftrightarrow x^2 - 4x + 5 - 10^a = 0.$$

Hosil bo'lgan tenglama  $D \geq 0$  bo'lganda yechimga ega:

$$16 - 4(5 - 10^a) \geq 0 \Leftrightarrow 4 - 5 + 10^a \geq 0 \Leftrightarrow 10^a \geq 1 \Rightarrow [a \geq 0.$$

Javob:  $[0; +\infty)$ .

## 6-§. Logarifmik tenglamalar

1. O'zgaruvchi logarifm belgisi ostida qatnashgan tenglamalar logarifmik tenglamalar deyiladi. Eng sodda logarifmik tenglama  $\log_a x = b$  (bunda  $a > 0, a \neq 1$ ) ko'rinishda bo'lib, uning ildizi  $x = a^b$ .

2.  $\log_a f(x) = \log_a \varphi(x)$  (bunda  $a > 0, a \neq 1, f(x) > 0, \varphi(x) > 0$ ) tenglamaning yechilishi, ko'rsatilgan shartlar bajarilganda bu tenglama  $f(x) = \varphi(x)$  tenglamaga teng kuchli ekanligiga asoslanadi.  $\log_a f(x) = \log_a \varphi(x)$  tenglamadan  $f(x) = \varphi(x)$  tenglamaga o'tilayotganda ayrim hollarda chet ildizlar paydo bo'lishini eslatib o'tamiz. Chet ildizlar topilgan ildizlarni berilgan tenglamaga qo'yib ko'rish yo'li orqali yoki tenglamaning aniqlanish sohasi bilan solishtirish yordamida aniqlanadi.

3. Asos ham, daraja ko'rsatkichi ham o'zgaruvchiga bog'liq bo'lgan tenglamalarni yechishda logarifmlash usuli qo'llaniladi.

Bunda agar daraja ko'rsatkichida logarifm ishtirok etsa, u holda tenglamaning har ikkala qismini shu logarifm asosi bo'yicha logarifmlash kerak.

**6.1. Logarifmik tenglamalarni yechish usullari. 1. Logarifmning ta'rifidan foydalanib yechiladigan tenglamalar.**

1-misol.  $\log_{\sqrt{4}}(x-1) = 6$  tenglamani yeching.

Yechilishi. Tenglamani aniqlanish sohasi:  $x > 1$ . Berilgan tenglamani logarifmning ta'rifidan foydalanib yechamiz:

$$\log_{\sqrt[3]{4}}(x-1) = 6 \Leftrightarrow (x-1) = (\sqrt[3]{4})^6 \Leftrightarrow x-1 = 16 \Leftrightarrow [x = 17.$$

Javob: 17.

2-misol.  $\log_{\sqrt[3]{4}}(x^2 - 5x + 10) = 2$  tenglamani yeching.

Yechilishi. Tenglamani aniqlanish sohasini topamiz:

$$\begin{cases} x-1 > 0, \\ x-1 \neq 1, \\ x^2 - 5x + 10 > 0 \end{cases} \Rightarrow \begin{cases} x > 1, \\ x \neq 2. \end{cases}$$

Tenglamani yechamiz:

$$\log_{\sqrt[3]{4}}(x^2 - 5x + 10) = 2 \Leftrightarrow x^2 - 5x + 10 = (x-1)^2 \Leftrightarrow x^2 - 5x + 10 = x^2 - 2x + 1 \Leftrightarrow 3x = 9 \Leftrightarrow [x = 3.$$

Javob: {3}.

**6.2.  $\log_a f(x) = \log_a \varphi(x)$  tenglamani  $f(x) = \varphi(x)$  tenglamaga teng kuchli ekanligidan foydalanib yechiladigan tenglamalar.**

3-misol.  $\log_3(x^2 - 4x - 5) = \log_3(7 - 3x)$  tenglamani yeching.

Yechilishi. Tenglamani aniqlanish sohasini topamiz:

$$\begin{cases} x^2 - 4x - 5 > 0, \\ 7 - 3x > 0 \end{cases} \Leftrightarrow \begin{cases} (x+1)(x-5) > 0, \\ x < 2\frac{1}{3} \end{cases} \Rightarrow \{x \in (-\infty; -1)\}.$$

Berilgan tenglamani yechamiz:  $\log_3(x^2 - 4x - 5) = \log_3(7 - 3x) \Leftrightarrow$

$$\Leftrightarrow x^2 - 4x - 5 = 7 - 3x \Leftrightarrow x^2 - x - 12 = 0 \Rightarrow \begin{cases} x_1 = -3, \\ x_2 = 4. \end{cases}$$

Bu yerda  $x = 4$  soni tenglamani aniqlanish sohasiga tegishli emas, shu sababli u chet ildiz. Shunday qilib, tenglama yagona  $x = -3$  ildizga ega.

Javob: -3.

4-misol.  $\lg(x-6) - \frac{1}{2} \lg 2 = \lg 3 + \lg \sqrt{x-10}$  tenglamani yeching.

Yechilishi. Tenglamani aniqlanish sohasini aniqlaymiz.

$$\begin{cases} x-6 > 0, \\ x-10 > 0 \end{cases} \Leftrightarrow \begin{cases} x > 6, \\ x > 10 \end{cases} \Rightarrow x > 10.$$

Logarifmning aniqlanish sohasidan foydalanib, berilgan tenglamada ushbu shakl almashtirishlarni amalga oshirib, tenglama ildizlarini topamiz:

$$\begin{aligned} \lg(x-6) - \frac{1}{2}\lg 2 &= \lg 3 + \lg \sqrt{x-10} \Leftrightarrow 2\lg(x-6) - \lg 2 = 2\lg 3 + \\ + 2\lg \sqrt{x-10} &\Leftrightarrow \lg \frac{(x-6)^2}{2} = \lg 3^2 + \lg(x-10) \Leftrightarrow \frac{(x-6)^2}{2} = 9(x-10) \Leftrightarrow \\ \Leftrightarrow x^2 - 12x + 36 &= 18x - 180 \Leftrightarrow x^2 - 30x + 216 = 0 \Rightarrow \\ \Rightarrow x_{1,2} &= 15 \pm \sqrt{225 - 216} \Rightarrow \begin{cases} x_1 = 12, \\ x_2 = 18. \end{cases} \end{aligned}$$

Topilgan ildizlar tenglamaning aniqlanish sohasiga tegishli.  
Javob:  $\{12; 18\}$ .

### 6.3. Yordamchi o'zgaruvchi kiritish usuli bilan yechiladigan tenglamalar

5-misol.  $\log_x 5 \cdot \sqrt{5} - 1.25 = \log_x^2 \sqrt{5}$  tenglamani yeching.

Yechilishi. Tenglamaning aniqlanish sohasini topamiz:  $x > 0$ ;  $x \neq 1$ . Berilgan tenglamada tegishli shakl almashtirishlarni bajarib, uning ildizlarini aniqlaymiz:

$$\begin{aligned} \log_x 5 \cdot \sqrt{5} - 1.25 &= \log_x^2 \sqrt{5} \Leftrightarrow \log_x 5^{\frac{3}{2}} - \frac{5}{4} = \left( \log_x 5^{\frac{1}{2}} \right)^2 \Leftrightarrow \frac{3}{2} \log_x 5 - \\ - \frac{5}{4} &= \left( \frac{1}{2} \log_x 5 \right)^2. \end{aligned}$$

Yordamchi o'zgaruvchi  $y = \log_x 5$  ni kiritib,  $\frac{3}{2}y - \frac{5}{4} = \frac{y^2}{4} \Leftrightarrow$   
 $\Leftrightarrow y^2 - 6y + 5 = 0$  tenglamani hosil qilamiz. Uning ildizlari  $y_1 = 1$ ,  
 $y_2 = 5$ . Noma'lum  $x$  ni topish uchun ushbu  $\log_x 5 = 1$ ,  $\log_x 5 = 5$   
tenglamalarga ega bo'lamiz. Logarifm ta'rifidan:  $5 = x^1$ ,  $5 = x^5$ , bundan,  
 $x_1 = 5$ ,  $x_2 = \sqrt[5]{5}$ . Bu ildizlar tenglamaning aniqlanish sohasiga tegishli.

Javob:  $\{5; \sqrt[5]{5}\}$ .

#### 6.4. Bir xil asosga o'tish usuli.

6-misol.  $\log_{0.2}(4x) + \log_5(x^2 + 75) = 1$  tenglamani yeching.

Yechilishi. Tenglamani aniqlanish sohasi:  $x > 0$  Tenglamani 5 asosga o'tib yechamiz:  $\log_{0.2}(4x) + \log_5(x^2 + 75) = 1 \Leftrightarrow$

$$\begin{aligned} \Leftrightarrow \frac{\log_5(4x)}{\log_5 0.2} + \log_5(x^2 + 75) &= \log_5 5 \Leftrightarrow \frac{\log_5(4x)}{\log_5 \frac{1}{5}} + \log_5(x^2 + 75) = \\ &= \log_5 5 \Leftrightarrow \log_5 \frac{x^2 + 75}{4x} = \log_5 5 \Leftrightarrow \frac{x^2 + 75}{4x} = 5 \Leftrightarrow x^2 - 20x + 75 = 0 \Rightarrow \\ &\Rightarrow \begin{cases} x_1 = 5, \\ x_2 = 15. \end{cases} \end{aligned}$$

Javob:  $\{5; 15\}$ .

#### 6.5. Logarifmlash usuli

7-misol.  $x^{\log_3 x} = 9x$  tenglamani yeching.

Yechilishi. Berilgan tenglamani aniqlanish sohasi 1 dan farqli barcha musbat sonlar to'plamidan iborat, ya'ni  $x \in (0; 1) \cup (1; +\infty)$ .

Tenglamani har ikkala qismini 3 asos bo'yicha logarifmlaymiz:

$$\begin{aligned} x^{\log_3 x} = 9x &\Leftrightarrow \log_3(x^{\log_3 x}) = \log_3(9x) \Leftrightarrow \log_3 x \cdot \log_3 x = 2 + \log_3 x \Leftrightarrow \\ &\Leftrightarrow \log_3^2 x - \log_3 x - 2 = 0 \Rightarrow \begin{cases} \log_3 x = -1 \\ \log_3 x = 2 \end{cases} \Rightarrow \begin{cases} x_1 = \frac{1}{3}, \\ x_2 = 9 \end{cases} \end{aligned}$$

Javob:  $\{\frac{1}{3}; 9\}$ .

**6.6. Logarifmik tenglamalar sistemasi.** Logarifmik tenglamalar sistemasini yechishda ham logarifmlarning xossalaridan va yuqorida bayon qilingan usullardan foydalaniladi.

8-misol.  $\begin{cases} x^{\lg y} = 100, \\ \log_y x = 2. \end{cases} \quad (x > 0; x \neq 1; y > 0; y \neq 1)$  tenglamalar sistemasini yeching.

Yechilishi.

$$\begin{cases} x^{\lg y} = 100, \\ \log_3 x = 2. \end{cases} \Leftrightarrow \begin{cases} \lg y \cdot \lg x = \lg 100, \\ x = y^2. \end{cases} \Leftrightarrow \begin{cases} \lg y \cdot 2 \lg y = 2, \\ x = y^2. \end{cases} \Leftrightarrow \begin{cases} \lg^2 y = 1 \\ x = y^2 \end{cases} \Leftrightarrow$$

$$\Leftrightarrow \begin{cases} \lg y = 1, \\ x = y^2. \end{cases} \Rightarrow \begin{cases} x_1 = 100; & y_1 = 10, \\ x_2 = 0,01; & y_2 = 0,1. \end{cases}$$
$$\Leftrightarrow \begin{cases} \lg y = -1, \\ x = y^2. \end{cases}$$

Javob: (100; 10), (0,01; 0,1).

## 7-§. Logarifmik tengsizliklar

O'zgaruvchi logarifm belgisi ostida qatnashgan tengsizliklar logarifmik tengsizlik deyiladi.

**7.1. Logarifmik tengsizliklarni yechish.** Logarifmik tengsizliklarni yechishda  $y = \log_a x$  funksiya  $a > 1$  da o'sishini,  $0 < a < 1$  da kamayishini e'tiborga olish kerak. Shunga ko'ra

$\log_a f(x) < \log_a \varphi(x)$   
tengsizlik, agar  $a > 1$  bo'lsa,

$$\begin{cases} f(x) > 0, \varphi(x) > 0, \\ f(x) < \varphi(x) \end{cases}$$

sistemaga,  $0 < a < 1$  bo'lsa,

$$\begin{cases} \varphi(x) > 0, f(x) > 0, \\ f(x) > \varphi(x) \end{cases}$$

sistemaga teng kuchli bo'ladi.

**7.2. Logarifmik tengsizliklarni yechishga doir misollar**

1-misol.  $\log_3(12 - 2x - x^2) > 2$  tengsizlikni yeching.

Yechilishi. Berilgan tengsizlikning o'ng tomonini logarifm orqali ifodalab

$$\log_3(12 - 2x - x^2) > \log_3 9$$

tengsizlikni hosil qilamiz. Bu tengsizlik

$$\begin{cases} 12 - 2x - x^2 > 0 \\ 12 - 2x - x^2 > 9 \end{cases} \Rightarrow 12 - 2x - x^2 > 9 \quad (*)$$

tengsizlikka teng kuchlidir. (\*) tengsizlikni yechamiz:

$$12 - 2x - x^2 > 9 \Leftrightarrow x^2 + 2x - 3 < 0 \Leftrightarrow (x + 3)(x - 1) < 0 \Rightarrow (-3; 1).$$

Javob:  $(-3; 1)$

2-misol.  $\log_{0.5} \frac{5x-3}{x+2} > 1$  tengsizlikni yeching.

Yechilishi.  $\log_{0.5} \frac{5x-3}{x+2} > 1 \Leftrightarrow \log_{0.5} \frac{5x-3}{x+2} > \log_{0.5} 0.5 \Leftrightarrow$

$$\Leftrightarrow \begin{cases} \frac{5x-3}{x+2} > 0, \\ \frac{5x-3}{x+2} < 0.5. \end{cases}$$

Berilgan tengsizlikka teng kuchli bo'lgan bu tengsizliklar sistemasidagi birinchi tengsizlik logarifmik funksiyaning aniqlanish sohasini tavsiflasa, ikkinchisi bu funksiyani  $0 < 0.5 < 1$  asosda kamayishini anglatadi. Shu sistemani yechamiz:

$$\begin{cases} \frac{5x-3}{x+2} > 0, \\ \frac{5x-3}{x+2} - 0.5 < 0. \end{cases} \Leftrightarrow \begin{cases} \frac{5x-3}{x+2} > 0, \\ \frac{5x-3-0.5x-1}{x+2} < 0. \end{cases} \Leftrightarrow \begin{cases} \frac{5x-3}{x+2} > 0, \\ \frac{4.5x-4}{x+2} < 0. \end{cases}$$

Bu sistemaning yechimi 107-rasmda tasvirlangan.

Javob:  $(\frac{3}{5}; \frac{8}{9})$ .

3-misol.  $\log_5 x + \log_5(x+1) \leq \log_5(2x+6)$  tengsizlikning eng katta butun yechimini toping.

Yechilishi.

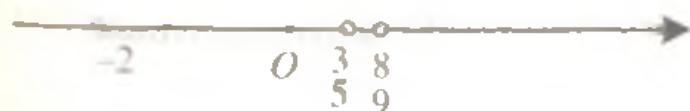

107-rasm



$$\log_5 x + \log_5 (x+1) \leq \log_5 (2x+6) \Leftrightarrow \begin{cases} x > 0, \\ x+1 > 0, \\ 2x+6 > 0, \\ \log_5 x(x+1) \leq \log_5 (2x+6) \end{cases} \Leftrightarrow$$

$$\begin{cases} x > 0, \\ x(x+1) \leq 2x+6 \end{cases} \Leftrightarrow \begin{cases} x > 0, \\ x^2 - x - 6 \leq 0. \end{cases} \Leftrightarrow \begin{cases} x > 0, \\ (x-3)(x+2) \leq 0. \end{cases} \Rightarrow [0; 3].$$

Berilgan tengsizlikning yechimi bo'lgan  $(0; 3]$  oraliqdagi eng katta butun son 3 ga teng.

Javob: 3.

4-misol.  $x^{\log_2 x+5} < 64$  tengsizlikni yeching.

Yechilishi. Tengsizlikning chap qismidagi logarifmik funktsiya  $x > 0$  da aniqlangan. Tengsizlikning shu shartni qanoatlantiruvchi yechimlarni topish uchun uning har ikkala qismini 2 asosga ko'ra logarifmlaymiz:

$$\log_2 (x^{\log_2 x+5}) < \log_2 64 \Leftrightarrow (\log_2 x + 5) \log_2 x < 6 \Leftrightarrow \log_2^2 x + 5 \log_2 x - 6 < 0 \Rightarrow [\log_2 x = t] \Rightarrow t^2 + 5t - 6 < 0 \Rightarrow (t+6)(t-1) < 0 \Rightarrow -6 < t < 1.$$

Shunday qilib, berilgan tengsizlik

$$\begin{cases} \log_2 x > -6, \\ \log_2 x < 1. \end{cases} \text{ tengsizliklar sistemasiga keltiriladi. Bundan } x > 2^{-6},$$

$x < 2.$

Javob:  $(2^{-6}; 2)$

5-misol.  $\log_{2x+3} x^2 < 1$  tengsizlikni yeching.

Yechilishi. Tengsizlik chap qismidagi logarifmik funktsiya o'zgaruvchining  $x > -1,5$ ,  $x \neq -1$  va  $x \neq 0$  qiymatlarida aniqlangan. Berilgan tengsizlikni quyidagi ko'rinishda yozamiz:

$$\log_{2x+3} x^2 < \log_{2x+3} (2x+3).$$

Bu yerda ikki hol qaralishi kerak:  $2x+3 > 1$  va  $0 < 2x+3 < 1$ . Shunga ko'ra,

$$\log_{2x+3} x^2 < \log_{2x+3} (2x+3) \Leftrightarrow \begin{cases} 2x+3 > 1, \\ x^2 < 2x+3; \\ 0 < 2x+3 < 1, \\ x^2 > 2x+3; \end{cases} \Leftrightarrow \begin{cases} x > -1, \\ (x-3)(x+1) < 0; \\ x > -1,5, \\ x < -1, \\ (x-3)(x+1) > 0; \end{cases}$$

$$\begin{cases} -1 < x < 3, \\ -1.5 < x < -1; \end{cases} \Rightarrow (-1.5; -1) \cup (-1; 3),$$

Berilgan tengsizlikning chap qismidagi  $\log_{2x+3} x^2 < 1$  logarifmik funksiya  $x = 0$  da ham aniqlanmaganligi uchun tengsizlikning yechimi  $(-1.5; -1)$ ,  $(-1; 0)$  va  $(0; 3)$  oraliqlar birlashmasidan iborat bo'ladi.

Javob:  $(-1.5; -1) \cup (-1; 0) \cup (0; 3)$

**7.3. Logarifmik tengsizliklar sistemasi.** Logarifmik tengsizliklar sistemalarini yechishda algebraik tengsizliklar sistemalarini yechishning ma'lum usullari logarifmning xossalaridan foydalangan holda ishlatiladi.

$$6\text{-misol.} \quad \begin{cases} (x-1)\lg 2 + \lg(2^{x+1} + 1) < \lg(7 \cdot 2^x + 12), \\ \log_x(x+2) > 2 \end{cases} \quad \text{tengsizliklar}$$

sistemasini yeching.

Yechilishi. Sistemaning birinchi tengsizligida qatnashayotgan logarifmik funksiyalar o'zgaruvchi  $x$  ning har qanday qiymatlarida aniqlangan bo'lsa, ikkinchi tengsizlikdagi  $\log_x(x+2)$  logarifmik funksiya o'zgaruvchining musbat va 1 dan farqli qiymatlarida aniqlangan. Shu sababli, sistemaning aniqlanish sohasi  $(0; 1)$  va  $(1; +\infty)$  oraliqlar birlashmasidan iborat.

Berilgan tengsizliklar sistemasini yechamiz:

$$\begin{cases} (x-1)\lg 2 + \lg(2^{x+1} + 1) < \lg(7 \cdot 2^x + 12), \\ \log_x(x+2) > 2; \end{cases} \Leftrightarrow$$

$$\Leftrightarrow \begin{cases} \lg 2^{x-1} \cdot (2^{x+1} + 1) < \lg(7 \cdot 2^x + 12), \\ x > 1, \\ x+2 > x^2; \end{cases} \Leftrightarrow \begin{cases} 2^{2x} + 2^{x+1} < 7 \cdot 2^x + 12, \\ x > 1, \\ x^2 - x - 2 < 0; \end{cases} \Leftrightarrow$$

$$\Leftrightarrow \begin{cases} \lg 2^{x-1} \cdot (2^{x+1} + 1) < \lg(7 \cdot 2^x + 12), \\ 0 < x < 1, \\ x+2 < x^2; \end{cases} \Leftrightarrow \begin{cases} 2^{2x} + 2^{x-1} < 7 \cdot 2^x + 12, \\ 0 < x < 1, \\ x^2 - x - 2 > 0; \end{cases} \Leftrightarrow$$

$$\begin{cases} 2 \cdot 2^{2x} - 13 \cdot 2^x - 24 < 0, \\ 1 < x < 2; \end{cases} \Leftrightarrow [1 < x < 2, \\ \{\emptyset$$

Javob:  $(1; 2)$ .

## Mustaqil ishlash uchun test topshiriqlari

1.  $y = a^x$  va  $y = \left(\frac{1}{a}\right)^x$  funksiyalarning ( $a > 0; a \neq 1$ ) grafiklari uchun ushbu tasdiqlarning qaysi biri noto'g'ri?

A) Har birining ham grafigi  $(0; 1)$  nuqtadan o'tadi;

B) Ularning grafiklari abssissalar o'qiga nisbatan o'zaro simmetrik;

C) Ularning grafiklari ordinatalar o'qiga nisbatan o'zaro simmetrik;

D) Ularning grafiklari  $Ox$  o'qidan yuqorida joylashadi;

E) Ularning grafiklari koordinatalar boshiga nisbatan simmetrik emas.

2.  $y = 2^x - 2$  funksiyaning qiymatlari to'plamini ko'rsating.

A)  $(0; +\infty)$ ; B)  $(-2; +\infty)$ ; C)  $(1; +\infty)$ ; D)  $(-\infty; +\infty)$ ; E)  $[-2; 0]$ .

3.  $y_1 = \frac{a^x + a^{-x}}{2}$ ,  $y_2 = \frac{a^x + 1}{a^x - 1}$ ,  $y_3 = \frac{x}{a^x - 1}$  va  $y_4 = \frac{a^x - 1}{a^x + 1}$  x funksiyalardan qaysi biri juft funksiya?

A)  $y_1, y_2$ ; B)  $y_1$ ; C)  $y_2$ ; D)  $y_1, y_4$ ; E)  $y_1, y_3$ .

4.  $y = \log_3(-3x)$  funksiyaning aniqlanish sohasini toping.

A)  $(-\infty; 0)$ ; B)  $(-\infty; 3)$ ; C)  $(3; +\infty)$ ; D)  $(-3; +\infty)$ ; E)  $(0; +\infty)$ .

5.  $y = \log_2(x + 6) + \log_2(6 - x)$  funksiyaning aniqlanish sohasiga tegishli butun sonlar nechta?

A) 6; B) 7; C) 10; D) 11; E) 5.

6.  $y = \sqrt{\log_{0.5} \frac{x}{x^2 - 1}}$  funksiyaning aniqlanish sohasini toping.

A)  $(0,5(1 - \sqrt{5}); 0) \cup (0,5(1 + \sqrt{5}); +\infty)$ ;

B)  $(-1; 0) \cup (1; +\infty)$ ; C)  $(0; 1)$ ;

D)  $(0,5(1 - \sqrt{5}); 0,5(1 + \sqrt{5}))$ ; E)  $(-1; 1)$ .

7. Quyidagi funksiyalardan qaysilari toq funksiya?

$y_1 = \ln \frac{1+x}{1-x}$ ,  $y_2 = x^2 \frac{a^x + 1}{a^x - 1}$ ,  $y_3 = \frac{2}{a^{2x} + a^{-2x}}$ .

A)  $y_1$ ; B)  $y_2$ ; C)  $y_3$ ; D)  $y_2, y_3$ ; E)  $y_1, y_2$ .

8.  $y = \log_{\frac{1}{2}}(x+2)$  funksiyaning grafigi qaysi choraklarda joy-

lashgan?

A) II, IV; B) II, III, IV; C) II, III; D) I, IV; E) I, II, III.

9.  $y = \left| \log_{\frac{1}{2}}(x+2) \right|$  funksiyaning grafigi qaysi choraklarda joylashgan?

A) II, IV; B) II, III, IV; C) II, I; D) I, IV; E) I, II, III.

10.  $y_1 = (10^{-1})^x$ ,  $y_2 = 10^x$ ,  $y_3 = \left(\frac{3}{10}\right)^x$ ,  $y_4 = 3 \cdot (10^{-2})^x$  funksiyalardan qaysilari kamayuvchi?

A)  $y_1, y_2$ ; B)  $y_2$ ; C)  $y_2, y_3$ ; D)  $y_1, y_2, y_3$ ; E)  $y_1, y_3, y_4$ .

11.  $p = \log_{1,2} \frac{5}{7}$ ;  $q = \log_{0,8} \frac{3}{6}$ ;  $m = \log_{1,5} 0,5$  va  $n = \log_{0,5} 4,5$  sonlardan qaysilari musbat?

A) Faqat  $q$ ; B)  $p$  va  $q$ ; C)  $m$  va  $n$ ; D)  $p$  va  $m$ ; E)  $q$  va  $n$ .

12.  $a = \log_{\frac{1}{5}} \frac{1}{4}$ ,  $b = \log_{\frac{1}{5}} \frac{1}{3}$ ,  $c = \log_{\frac{1}{3}} 3$  sonlarni o'sish tartibida yozing.

A)  $a < b < c$ ; B)  $c < a < b$ ; C)  $c < b < a$ ; D)  $b < a < c$ ; E)  $a < c < b$ .

13.  $m = \log_6 \frac{1}{4}$ ,  $n = \log_6 \frac{1}{3}$ ,  $l = \log_{\frac{1}{8}} 64$  sonlarni kamayish tartibida yozing.

A)  $m > n > l$ ; B)  $n > m > l$ ; C)  $n > l > m$ ; D)  $m > l > n$ ; E)  $l > n > m$ .

14. Agar  $\log_3 2 = a$  bo'lsa,  $\log_3 6$  ni  $a$  orqali ifodalang.

A)  $a + 1$ ; B)  $3a$ ; C)  $a - 1$ ; D)  $a - 3$ ; E)  $\frac{2}{a}$ .

15. Agar  $\log_2 3 = n$  bo'lsa,  $\log_2 \sqrt{0,75}$  ni  $n$  orqali ifodalang.

A)  $\frac{n-3}{2}$ ; B)  $\frac{2-n}{3}$ ; C)  $\frac{n-4}{3}$ ; D)  $\frac{n-10}{3}$ ; E)  $\frac{n-2}{3}$ .

16. Agar  $\log_5 2 = a$ ,  $\log_5 3 = c$  bo'lsa,  $\log_5 12$  ni  $a$  va  $c$  orqali ifodalang.

A)  $c - 2a$ ; B)  $2a - c$ ; C)  $2a + c$ ; D)  $2a \cdot c$ ; E)  $a \cdot c$ .

17\*. Agar  $\log_{12} 5 = a$ ,  $\log_{12} 11 = b$  bo'lsa,  $\log_{275} 60$  ni  $a$  va  $b$  orqali ifodalang.

A)  $\frac{a+1}{2a+b}$ ; B)  $\frac{a-1}{2a+b}$ ; C)  $\frac{2a+b}{a+1}$ ; D)  $\frac{2a+b}{a-1}$ ; E)  $5a + 12b$ .

18\*. Agar  $\log_7 12 = a$ ,  $\log_{12} 24 = c$  bo'lsa,  $\log_{54} 168$  ni  $a$  va  $c$  orqali ifodalang.

A)  $\frac{a+c}{8a-5c}$ ; B)  $\frac{1+ac}{8a-5ac}$ ; C)  $\frac{1+ac}{8a-5c}$ ; D)  $\frac{8a-5ac}{1+ac}$ ; E)  $\frac{8a-5c}{1+ac}$ .

19.  $16^{0,5 \log_{10} 10+1}$  ni hisoblang.

A) 40; B) 26; C) 160; D) 56; E) 176.

20.  $27^{\frac{1}{3} \log_1 0,5 - \log_{27} 2}$  ni hisoblang.

A) 1; B)  $\sqrt[3]{4}$ ; C) 9; D) 3; E)  $\frac{1}{3}$ .

21.  $3 \log_2 \log_4 16 + \log_{0,5} 2$  ni hisoblang.

A)  $\log_2 3$ ; B) 2; C)  $\log_2 3 + 1$ ; D) 3; E)  $\log_2 3 - 1$ .

22\*.  $\sqrt{25^{\frac{1}{\log_6 5}} + 49^{\frac{1}{\log_8 7}}}$  ni soddalashtiring.

A)  $\sqrt{74}$ ; B)  $\sqrt{10}$ ; C)  $\sqrt{14}$ ; D) 10; E) 100.

23.  $-\log_2 \log_2 \sqrt[4]{2}$  ni soddalashtiring.

A)  $-\frac{1}{8}$ ; B)  $-\log_2 3$ ; C) -3; D) 4; E) 3.

24.  $8^{\log_2 3} (\lg 6,7 - \lg 0,67)$  ni hisoblang.

A) 3; B) 9; C) 27; D) 30; E) 270.

25.  $\frac{\log_4^2 12 + \log_4 12 \cdot \log_4 3 - 2 \log_4^2 3}{\log_4 12 + 2 \log_4 3}$  ni soddalashtiring.

A)  $\log_4 3$ ; B)  $-\log_4 3$ ; C) 2; D) 1; E) -1.

26.  $\log_3 4 \cdot \log_4 5 \cdot \log_5 6 \cdot \log_6 7 \cdot \log_7 8 \cdot \log_8 9$  ni hisoblang.

A) 2; B) 3; C) 4; D) 6; E) 9.

27.  $a = \log_{0,2} 8$ ,  $b = \log_3 0,8$ ,  $c = \log_{0,9} 2$ ,  $d = \log_4 2$ ,  $l = \log_{0,5} 0,2$  sonlaridan qaysilari musbat?

A)  $a$  va  $d$ ; B)  $b$  va  $d$ ; C)  $a$ ,  $c$  va  $d$ ; D)  $c$  va  $d$ ; E)  $d$  va  $l$ .

28.  $y = \log_3 (81^{-x} - 3^{x^2+3})$  funksiyaning aniqlanish sohasini toping.

A)  $(0; \infty)$ ; B)  $(-3; -1)$ ; C)  $(1; 3)$ ; D)  $(-\infty; 1) \cup (3; +\infty)$ ;

E)  $(-\infty; -3) \cup (-2; +\infty)$ .

29.  $\left[ \left( 3 \cdot 1287^3 \cdot e^{-\ln 48} \right)^{\frac{1}{2}} - \sqrt{3} \right]^2 + \frac{12}{\sqrt{6}}$  ni hisoblang.

- A) 1; B) 2; C) 3; D) 4; E) 5.

30\*.  $\left( \frac{1}{8} \right)^{\log_{2\sqrt{2}} \left( \frac{1}{4} - \frac{1}{8} + \frac{1}{16} - \frac{1}{32} + \dots \right)}$  ni hisoblang.

- A) 36; B) 24; C) 32; D) 28; E) 16.

31.  $3^{6-x} = 3^{3x-2}$  tenglamani yeching.

- A) 6; B) 4; C) 2; D) -2; E) 1.

32.  $\left( \frac{1}{\sqrt{2}} \right)^{x^3-9x} = 1$  tenglamaning ildizlari nechta?

- A) tenglamaning ildizlari yo'q; B) 1 ta; C) 2 ta;  
D) 3 ta; E) 4 ta.

33.  $2^x \cdot 5^x = 0,1 \cdot (10^{x-1})^5$  tenglamani yeching.

- A) 5; B) -5; C) 2; D) 1,5; E) -1,5.

34.  $4^{x+1,5} + 2^{x+2} = 4$  tenglamaning ildizlari yig'indisini toping.

- A) -1; B) 0; C) 1; D) 2; E) 3.

35.  $3^{3x+1} - 4 \cdot 27^{x-1} + 9^{1,5x-1} = 80$  tenglamaning ildizlarini toping.

- A) 1 va -1; B) 1; C) -1; D) 0; E) 2.

36.  $3^{2x+4} + 45 \cdot 6^x - 9 \cdot 2^{2x+2} = 0$  tenglama ildizi 10 dan qancha-ga kichik?

- A) 8; B) 6; C) 2; D) 14; E) 12.

37.  $3 \cdot 4^x - 5 \cdot 6^x + 2 \cdot 9^x = 0$  tenglamaning ildizlari yig'indisini toping.

- A) 0; B) -1; C) 1; D) 2; E) 4.

38\*.  $\left( \sqrt{2-\sqrt{3}} \right)^x + \left( \sqrt{2+\sqrt{3}} \right)^x = 4$  tenglama nechta ildizga ega?

- A) tenglamaning ildizlari yo'q; B) 4 ta; C) 3 ta;  
D) 2 ta; E) 1 ta.

39.  $3^{x+1} + 3^{x-1} + 3^{x-2} = 5^x + 5^{x-1} + 5^{x-2}$  tenglamaning ildizlarini toping.

- A) -2; B) -1; C) 0; D) 1; E) 2.

40\*.  $(x-3)^{x^2} = (x-3)^x$  tenglama nechta ildizga ega?  
A) 4; B) 3; C) 2; D) 1; E) tenglamaning ildizlari yo'q;

41\*.  $(x^2 - x - 1)^{x^2 - 1} = 1$  tenglama ildizlarining ko'paytmasini toping.  
A) -1; B) 0; C) 1; D) -2; E) 2.

42. 
$$\begin{cases} 2^x \cdot 3^y = 12, \\ 2^y \cdot 3^x = 18 \end{cases}$$
 tenglamalar sistemasini yeching.

A) (2; 1); B) (1; 2); C) (-2; 1); D) (2; -1); E) (0; 0).

43\*. 
$$\begin{cases} x + y = 6, \\ y^{x^2 - 7x + 12} = 1 \end{cases}$$
 tenglamalar sistemasi nechta yechimga ega?

A) 4; B) 3; C) 2; D) 1; E) sistema yechimga ega emas.

44.  $\log_2(x^2 + 4x + 3) = 3$  tenglamani yeching.

A) -5 va 1; B) tenglamaning ildizlari yo'q; C) -5; D) 1;  
E) -3.

45.  $\log_{\sqrt[3]{4}}(x-1) = 6$  tenglama ildizi joylashgan oraliqlarni ko'rsating.

A)  $(-\infty; -1)$ ; B)  $(-1; 0)$ ; C)  $(0; 1)$ ; D)  $(1; +\infty)$ ; E)  $(15; +\infty)$ .

46.  $\log_5(x+1) - \log_5(2x+3) = 1$  tenglamaning ildizlarini toping.

A) tenglamaning ildizlari yo'q; B) 0; C) 1; D) -3; E) 2 va 3.

47.  $\log_5^2 x - \log_{\sqrt{5}} x - 3 = 0$  tenglamaning ildizlari ko'paytmasini toping.

A) 1; B) 10; C) -10; D) 25; E) -25.

48.  $\log_5^2 x + \log_{0.2} x = 2$  tenglamaning butun ildizini ko'rsating.

A) 2; B) 5; C) 10; D) 15; E) 25.

49.  $x^{\lg x} = 10000$  tenglamaning ildizlari ko'paytmasini toping.

A) 0,01; B) 0,1; C) 1; D) 10; E) 100.

50.  $\frac{1}{\lg x - 6} + \frac{5}{\lg x + 2} = 1$  tenglama eng katta ildizining eng kichik ildiziga nisbatini toping.

A)  $10^2$ ; B)  $10^3$ ; C)  $10^4$ ; D)  $10^5$ ; E)  $10^6$ .

51.  $\log_3 x \cdot \log_9 x \cdot \log_{27} x \cdot \log_{81} x = \frac{2}{3}$  tenglamaning ildizlari ko'paytmasini toping.

A) 100; B) 1; C) 0,1; D) ...; E) 0,01.

52\*.  $\log_4(\log_2 x) + \log_2(\log_4 x) = 2$  tenglama ildizini toping.

A) 4; B) 8; C) 16; D) 32; E) 36.

53.  $4^{\lg x} - 32 + x^{\lg 4} = 0$  tenglamaning ildizlari yig'indisini toping.

A) 0,1; B) 10; C) 10,1; D) 100; E) 110.

54. 
$$\begin{cases} 2^{\frac{\log(3x-4)}{2}} = 8, \\ \log_0(x^2 - y^2) - \log_0(x + y) = 0,5 \end{cases}$$
 tenglamalar sistemasini

yeching.

A) (0; 1); B) (1; 1); C) (2; 1); D) (1; 3); E) (4; 1).

55\*. 
$$\begin{cases} 0,5^{x-2} \cdot 4^{y+1} = 16^{0,75}, \\ \log_2(2x - y)^2 = 2 \end{cases}$$
 tenglamalar sistemasini yeching.

A) (0; 1); B)  $(-\frac{5}{3}; -\frac{4}{3})$ , (1; 0); C)  $(-\frac{4}{3}; -\frac{5}{3})$ , (0; 1);  
D) (-5; -3); E)  $(\frac{5}{3}; \frac{4}{3})$ .

56.  $(0,5)^x < \frac{1}{64}$  tengsizlikning eng kichik butun yechimini toping.

A) 8; B) 7; C) 6; D) 4; E) 2.

57.  $2,56^{\sqrt{x}-1} \geq (\frac{5}{8})^{4\sqrt{x}+1}$  tengsizlikni yeching.

A) [0; 36]; B) [36; +∞); C)  $[\frac{1}{36}; +\infty)$ ; D)  $[-\frac{1}{36}; +\infty)$ ;  
E)  $[\frac{1}{6}; +\infty)$ .

58.  $\frac{4^x - 2^{x+1} + 8}{2^{1-x}} < 8^x$  tengsizlikni yeching.

A) (1; +∞); B) (4; 2); C)  $(-\infty; 4) \cup (2; +\infty)$ ;  
D) (2; +∞); E) (0; +∞).

59\*.  $(4x^2 + 2x + 1)^{x^2-x} > 1$  tengsizlikni yeching.



- A)  $(-\infty; -0,5)$ ;    B)  $(1; +\infty)$ ;    C)  $(-0,5; 1)$ ;  
 D)  $(-\infty; -0,5) \cup (1; +\infty)$ ;    E)  $(-\infty; 0) \cup (1; +\infty)$ .

60.  $1 < 3^{x^2-2x} < 9$  tengsizlik nechta butun yechimga ega?

- A) 8;    B) 6;    C) 4;    D) 1;    E) butun yechimlari yo'q.

61.  $x^2 2^x - 2^{2+x} \leq 0$  tengsizlikning butun yechimlari ko'paytmasini toping.

- A) 2;    B) 4;    C) 0;    D) -4;    E) 1.

62.  $3^{8x} - 4 \cdot 3^{4x} \leq -3$  tengsizlikning butun yechimlari yig'indisini toping.

- A) 6;    B) 4;    C) 0;    D) -1    E) -2.

63.  $3^{\log(x+3)} > 2x - 5$  tengsizlikning eng kichik butun yechimini toping.

- A) -3;    B) -2;    C) -1;    D) 2;    E) -2,5.

64.  $\log_8(x+1) + \log_8 x < \log_8 2$  tengsizlikni yeching.

- A) (0; 1);    B) (-2; 0);    C) (-2; 1);    D) (-1; 2);  
 E) (0; 2).

65.  $\log_5(x-3) < 2$  tengsizlikning eng kichik butun yechimi nechaga teng?

- A) 27;    B) 10;    C) 6;    D) 3;    E) 4.

66.  $\log_{5,2} \frac{x}{x+3} > 0$  tengsizlikni yeching

- A)  $(-\infty; -3)$ ;    B)  $(0; +\infty)$ ;    C)  $(-3; +\infty)$ ;    D)  $(-\infty; 0)$ ;  
 E)  $(-\infty; -3) \cup (-3; 0) \cup (0; +\infty)$ .

67.  $\log_{0,2} \frac{x^2-x}{x^2+1} > 0$  tengsizlikning eng kichik butun yechimini toping.

- A) 1;    B) 2;    C) -1;    D) -2;    E) 0.

68\*.  $\log_{0,5} \log_8 \frac{x^2+8x}{x-3} < 0$  tengsizlikning eng kichik yechimi 8 dan qancha kam?

- A) 5;    B) 4;    C) 3;    D) 2;    E) 1.

69.  $x^{\lg x} \leq 100x$  tengsizlikning eng kichik va eng katta yechimlari ko'paytmasini toping.

- A) 1000;    B) 100;    C) 10;    D) 0,1;    E) 0,001.

70\*.  $\log_{\frac{1}{2}}(3-2x) > 1$  tengsizlikni yeching.

- A)  $(-3; 1)$ ; B)  $(1; 1,5)$ ; C)  $(0; 1)$ ; D)  $(-\infty; -3) \cup (1; +\infty)$ ;  
E)  $(-3; -1)$ .

71\*.  $\frac{\lg 7 - \lg(-8x-x^2)}{\lg(x+3)} > 0$  tengsizlikni yeching.

- A)  $(-3; -2) \cup (-1; 0)$ ; B)  $(0; -\infty)$ ; C)  $(-2; +\infty)$ ;  
D)  $(-3; -2)$ ; E)  $(-7; -1)$ .

72\*. Agar  $x = 2,25$  soni  $\log_a(3-x^2+2x) < \log_a(x^2-x-2)$  tengsizlikni qanoatlantirishi ma'lum bo'lsa, shu tengsizlikning yechimini toping.

- A)  $(1,5; 3)$ ; B)  $(2; 2,5)$ ; C)  $(2; 3)$ ; D)  $(1,5; 3,5)$ ; E)  $(1; 3)$ .

73.  $\log_{3x^2+5}(9x^4+27x^2+28) > 2$  tengsizlikning butun yechimini toping.

- A) 3; B) 2; C) 1; D) 0; E) -1.

74.  $\log_2 \log_1 \log_5 x > 0$  tengsizlikning eng katta butun yechimini ko'rsating.

- A) 1; B) 2; C) 3; D) 4; E) 5.

75\*.  $\log_{0,1}(x+5)^8 > \log_{0,1}(3x-1)^8$  tengsizlikni yeching.

- A)  $(-\infty; -5) \cup (-5; -1) \cup (3; +\infty)$ ; B)  $(-\infty; -1) \cup (3; +\infty)$ ;  
C)  $(-\infty; -5) \cup (3; +\infty)$ ; D)  $(-\infty; -5)$ ; E)  $(-\infty; 1)$ .

## TRIGONOMETRIYA ELEMENTLARI. TRIGONOMETRIK FUNKSIYALAR

### 1-§. Burchaklarning gradus va radian o'lchovlari

Har qanday burchakni nurni o'zining boshlang'ich nuqtasi atrofida aylanishi natijasi deb qarash mumkin. Masalan, nurni  $O$  nuqta atrofida boshlang'ich vaziyat  $OA$  dan  $OB$  holatgacha burib,  $OAB$  burchakni hosil qilamiz (108-rasm).

**1.1. Burchakning gradus o'lchovi.** Odatda burchak kattaligining o'lchov birligi sifatida to'la aylanishning  $1/360$  ulushi qabul qilingan bo'lib, bu birlik gradus deb ataladi va  $1^\circ$  kabi belgilanadi.

Bir gradusli burchak shunday burchakki, bu burchakni nur o'zining boshlang'ich nuqtasi atrofida soat mili yo'nalishiga teskari yo'nalishda to'la aylanishning  $1/360$  qismiga burilib hosil qiladi.

Gradusning  $1/60$  ulushi minut deyilib,  $1'$  kabi belgilanadi, minutning  $1/60$  ulushi esa sekund deb atalib,  $1''$  kabi belgilanadi.

**1.2. Burchaklarning ishoralari.** Ba'zan nurning qaysi yo'nalishda burilishini aniq ko'rsatish ahamiyatga ega bo'ladi. Odatda, nur

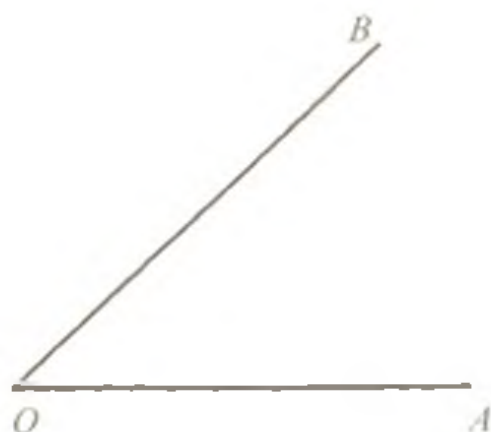

108-rasm

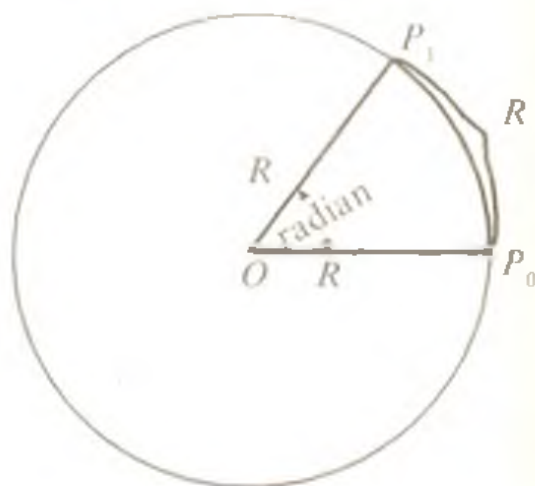

109-rasm

soat mili harakati yo'nalishiga teskari yo'nalishda bo'lsa, burchakning o'lchovi *musbat* deb, aks holda *manfiy* deb qabul qilinadi.

**1.3. Burchakning radian o'lchovi.** Trigonometriyada burchaklarning gradus o'lchovi bilan bir qatorda radian o'lchovi deb ataladigan o'lchov ham ishlatiladi.

*O'z uzunligi aylana radiusiga teng bo'lgan yoyga tiralgan markaziy burchak 1 radian burchak deyiladi* (109-rasm). Uzunligi  $\pi R$  (yarim aylana) bo'lgan yoy  $180^\circ$  li markaziy burchakni tortib turganligi uchun uzunligi  $R$  bo'lgan yoy  $\pi$  marta kichik bo'lgan burchakni tortib turadi, ya'ni

$$1 \text{ rad} = \left(\frac{180}{\pi}\right)^\circ.$$

$\pi \approx 3.14$  bo'lgani uchun  $1 \text{ rad} \approx 57.3^\circ \approx 57^\circ 17' 45''$ .

$180^\circ$  li burchakka  $\pi$  rad mos kelganligidan

$$1^\circ = \frac{\pi}{180} \text{ rad}$$

bo'ladi.

Agar burchak  $\alpha$  radiandan iborat bo'lsa, u holda uning gradus o'lchovi

$$\alpha \text{ rad} = \left(\frac{180}{\pi} \alpha\right)^\circ \quad (1)$$

bo'ladi.

Agar burchak  $\alpha$  gradusdan iborat bo'lsa, u holda uning radian o'lchovi

$$\alpha^\circ = \frac{\pi}{180} \alpha \text{ rad} \quad (2)$$

bo'ladi.

1 - masala. 1)  $\frac{\pi}{6}$  rad; 2)  $\frac{\pi}{4}$  rad; 3)  $\frac{\pi}{3}$  rad; 4)  $\frac{\pi}{2}$  rad; 5)  $\frac{3\pi}{4}$  rad; 6)  $\frac{5\pi}{6}$  rad ga teng burchaklarning gradus o'lchovlarini toping.

Yechilishi. Burchakning radian o'lchovidan gradus o'lchoviga o'tish uchun (1) formuladan foydalanamiz:

$$1) \frac{\pi}{6} \text{ rad} = \left(\frac{180}{\pi} \cdot \frac{\pi}{6}\right)^\circ = 30^\circ; \quad 2) \frac{\pi}{4} \text{ rad} = \left(\frac{180}{\pi} \cdot \frac{\pi}{4}\right)^\circ = 45^\circ;$$

$$3) \frac{\pi}{3} \text{ rad} = \left(\frac{180}{\pi} \cdot \frac{\pi}{3}\right)^\circ = 60^\circ; \quad 4) \frac{\pi}{2} \text{ rad} = \left(\frac{180}{\pi} \cdot \frac{\pi}{2}\right)^\circ = 90^\circ;$$

$$5) \frac{3\pi}{4} \text{ rad} = \left(\frac{180}{\pi} \cdot \frac{3\pi}{4}\right)^\circ = 135^\circ; \quad 6) \frac{5\pi}{6} \text{ rad} = \left(\frac{180}{\pi} \cdot \frac{5\pi}{6}\right)^\circ = 150^\circ;$$

Javob:  $30^\circ$ ;  $45^\circ$ ;  $60^\circ$ ;  $90^\circ$ ;  $135^\circ$ ;  $150^\circ$ .

2-masala. 1)  $15^\circ$ ;  $22,5^\circ$ ;  $75^\circ$ ;  $120^\circ$  ga teng burchaklarning radian o'lchovlarini toping.

Yechilishi. Burchakning gradus o'lchovidan radian o'lchoviga o'tish uchun (2) formuladan foydalanamiz:

$$1) 15^\circ = \frac{\pi}{180} \cdot 15 \text{ rad} = \frac{\pi}{12} \text{ rad};$$

$$2) 22,5^\circ = \frac{\pi}{180} \cdot 22,5 \text{ rad} = \frac{\pi}{8} \text{ rad};$$

$$3) 75^\circ = \frac{\pi}{180} \cdot 75 \text{ rad} = \frac{5\pi}{12} \text{ rad};$$

$$4) 120^\circ = \frac{\pi}{180} \cdot 120 \text{ rad} = \frac{2\pi}{3} \text{ rad}.$$

$$\text{Javob: } \frac{\pi}{180} \text{ rad}; \frac{\pi}{8} \text{ rad}; \frac{5\pi}{12} \text{ rad}; \frac{2\pi}{3} \text{ rad}.$$

## 2-§. Son argumentining sinusi, kosinusi, tangensi, kotangensi, sekansi, kosekansi

Markazi koordinata boshida bo'lib, radiusi  $R$  ga teng aylanada  $P_0(R;0)$  nuqtani belgilaymiz. Agar boshlang'ich radius  $OP_0$  kesma  $O(0;0)$  markaz atrofida  $\alpha$  burchakka burilsa,  $P_0(R;0)$  nuqta  $P_\alpha(x_\alpha; y_\alpha)$  nuqtaga o'tadi (110-a rasm).

Ta'riflar:

1.  $\alpha$  burchakning sinusi deb,  $P_\alpha$  nuqta ordinatasining radiusga nisbatiga aytiladi ( $\sin \alpha$  bilan belgilanadi), ya'ni

$$\sin \alpha = \frac{y_\alpha}{R}. \quad (1)$$

2.  $\alpha$  burchakning kosinusi deb,  $P_\alpha$  nuqta absissasining radiusga nisbatiga aytiladi ( $\cos \alpha$  bilan belgilanadi), ya'ni

$$\cos \alpha = \frac{x_\alpha}{R}. \quad (2)$$

3.  $\alpha$  burchakning tangensi deb,  $P_\alpha$  nuqta ordinatasining uning absissasiga nisbatiga aytiladi ( $\text{tg } \alpha$  bilan belgilanadi), ya'ni

$$\text{tg } \alpha = \frac{y_\alpha}{x_\alpha}. \quad (3)$$

4.  $\alpha$  burchakning kotangensi deb,  $P_\alpha$  nuqtaning absissasini uning ordinatasiga nisbatiga aytiladi ( $\text{ctg } \alpha$  bilan belgilanadi), ya'ni

$$\text{ctg } \alpha = \frac{x_\alpha}{y_\alpha}. \quad (4)$$

5.  $\alpha$  burchakning kosinusiga teskari kattalik sekans ( $\sec\alpha$ ), sinusga teskari kattalik kosekans ( $\csc\alpha$ ) deb ataladi, ya'ni

$$\sec\alpha = \frac{1}{\cos\alpha}, \quad (5); \quad \csc\alpha = \frac{1}{\sin\alpha}. \quad (6)$$

$\alpha$  burchakning sinusi, kosinusi, tangensi va kotangensining qiymatlari faqat  $\alpha$  burchakka bog'liq bo'lib, aylana radiusiga bog'liq emas. Masalan, quyida sinusning radiusga bog'liq emasligini ko'rsatamiz.  $OP_0$  nur  $O$  nuqta atrofida  $\alpha$  burchakka burilganda  $ON_0 = R_1$  va  $OP_0 = R_2$  radiuslar  $ON_1$  va  $OP_1$  holatlarga o'tsin (110-b rasm).  $N_1$  nuqtaning koordinatalarini  $x_1$  va  $y_1$  orqali,  $P_1$  nuqtaning koordinatalarini  $x_2$  va  $y_2$  orqali belgilaymiz.  $N_1$  va  $P_1$  nuqtalardan  $Ox$  o'qiga perpendikularlar tushiramiz.  $ON_1N_2$  va  $OP_1P_2$  to'g'ri burchakli uchburchaklar o'xshashligidan

$$\frac{N_1N_2}{ON_1} = \frac{P_1P_2}{OP_1}, \quad \text{ya'ni} \quad \frac{|y_1|}{R_1} = \frac{|y_2|}{R_2}.$$

$N_1$  va  $P_1$  nuqtalar bitta chorakka tegishli bo'lganligi sababli, ularning ordinatalarining ishoralari bir xildir, demak.

$$\frac{y_1}{R_1} = \frac{y_2}{R_2}.$$

Shunday qilib, har qanday burchak uchun  $\frac{y}{R}$  nisbat  $R$  radiusga bog'liq emas.

Xuddi shunga o'xshash, kosinusning ham radiusga bog'liq emasligini ko'rsatish mumkin.

*Markazi koordinatalar boshida bo'lib, radiusi 1 birlikka teng bo'lgan aylana birlik aylana deb ataladi (111-rasm).*

Birlik aylanada  $R = 1$  bo'lgani uchun (1) va (2) tengliklar

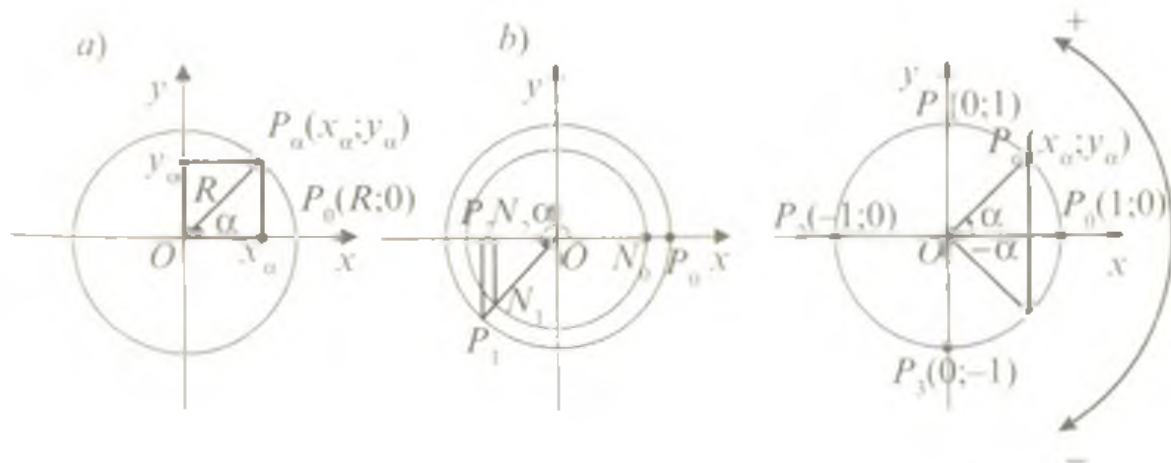

110-rasm

111-rasm

$$\sin\alpha = y_\alpha, \quad (1')$$

$$\cos\alpha = x_\alpha \quad (2')$$

ko'rinishda yoziladi. Shu sababli, burchakning sinusi nuqtaning ordinatasiga, kosinusi esa absissasiga teng deb ta'riflanadi. Shunga ko'ra (3) va (4) tengliklardan tangens va kotangens

$$\operatorname{tg}\alpha = \frac{\sin\alpha}{\cos\alpha} \quad (\cos\alpha \neq 0) \quad (3')$$

$$\operatorname{ctg}\alpha = \frac{\cos\alpha}{\sin\alpha} \quad (\sin\alpha \neq 0) \quad (4')$$

formulalar bilan ta'riflanishi kelib chiqadi.

Aylanada  $P_0(1; 0)$  nuqtani  $2\pi$  ( $360^\circ$ )ga burishda nuqta dastlabki holatiga qaytadi, uni  $-2\pi$  ga, ya'ni  $-360^\circ$  burishda ham yana dastlabki holatiga qaytadi. Nuqtani  $2\pi$  dan katta burchakka va  $-2\pi$  dan kichik burchakka burishda ham shunday holat kuzatiladi. Masalan,  $P_0(1;0)$  nuqtani  $\frac{5\pi}{2} = 2\pi + \frac{\pi}{2}$ ;  $\frac{9\pi}{2} = 2 \cdot 2\pi + \frac{\pi}{2}$ ,  $\frac{13\pi}{2} = 3 \cdot 2\pi + \frac{\pi}{2}$  burchaklarga burishda nuqta soat mili harakatiga qarama-qarshi yo'nalishda mos ravishda bitta, ikkita va uchta to'la aylanishni o'tadi va yana  $\frac{\pi}{2}$  yo'lni bosib o'tadi. Bunda  $P_0(1;0)$  nuqtani  $\frac{\pi}{2}$  burchakka burishdagi  $P_0(1; 0)$  nuqtani o'zi hosil bo'laveradi (III-rasm). Shunga o'xshash, nuqtani  $-\frac{5\pi}{2} = -2\pi - \frac{\pi}{2}$ ;  $-\frac{9\pi}{2} = -2 \cdot 2\pi - \frac{\pi}{2}$ ,  $-\frac{13\pi}{2} = -3 \cdot 2\pi - \frac{\pi}{2}$  burchaklarga burishda u soat mili harakati bo'yicha mos ravishda bitta, ikkita va uchta to'la aylanishni o'tadi va yana  $-\frac{\pi}{2}$  yo'lni bosib o'tadi va  $P_0(1; 0)$  nuqtani  $-\frac{\pi}{2}$  burchakka burishdagi nuqta  $P_3(0; -1)$  hosil bo'laveradi (III-rasm).

Umuman, agar  $\alpha = \alpha_0 + 2k\pi$  (bunda  $k$  - butun son,  $k \in Z$ ) bo'lsa, u holda  $\alpha$  burchakka burishda  $\alpha_0$  burchakka burishdagi nuqtaning o'zi hosil bo'ladi.

Shunday qilib, har bir haqiqiy  $\alpha$  songa birlik aylananing  $P_0(1;0)$  nuqtasini  $\alpha$  rad burchakka burish bilan hosil qilinadigan birgina nuqtasi mos keladi.

Har qanday  $\alpha$  burchakka yagona  $P_\alpha(x_\alpha; y_\alpha)$  nuqta mos kelgani uchun, shu burchak sinusi va kosinusining ham yagona qiymati mos keladi. Shuning uchun  $\sin\alpha$  va  $\cos\alpha$  son argumenti  $\alpha$  ning funksiyalaridir (geometriyada  $\sin\alpha$  va  $\cos\alpha$  lar  $\alpha$  burchak qiymatlarining funksiyalari sifatida qaralishini eslatib o'tamiz).

$\sin \alpha$  va  $\cos \alpha$  son argumenti  $\alpha (\alpha \in R)$  uchun ta'riflangan, ularning qiymatlari  $-1$  dan  $1$  gacha ekanligini,  $\operatorname{tg} \alpha$  faqat  $\cos \alpha \neq 0$ , ya'ni  $\alpha = \frac{\pi}{2} + k\pi (k \in Z)$  dan boshqa burchaklar uchun,  $\operatorname{ctg} \alpha$  esa faqat  $\sin \alpha \neq 0$  bo'lgan, ya'ni  $\alpha = k\pi (k \in Z)$  dan boshqa burchaklar uchun aniqlanganligini, ularning qiymatlarining to'plami barcha haqiqiy sonlar to'plamidan iborat ekanligini ta'kidlab o'tamiz.

Sinus, kosinus, tangens va kotangenslarning amaliy hisoblashlarda ko'proq ishlatiladigan qiymatlari 1-jadvalda keltirilgan:

1-misol.  $5 \sin \frac{\pi}{6} + 3 \operatorname{tg} \frac{\pi}{4} - \cos \frac{\pi}{4} - 10 \operatorname{tg} \frac{\pi}{4}$  ni hisoblang.

Yechilishi. Berilgan ifodaning qiymatini hisoblashda  $\sin \alpha$ ,  $\cos \alpha$  va  $\operatorname{tg} \alpha$  ning 1-jadvalda berilgan qiymatlaridan foydalanamiz:

$$5 \sin \frac{\pi}{6} + 3 \operatorname{tg} \frac{\pi}{4} - \cos \frac{\pi}{4} - 10 \operatorname{tg} \frac{\pi}{4} = 5 \cdot \frac{1}{2} + 3 \cdot 1 - \frac{\sqrt{2}}{2} - 10 \cdot 1 = \frac{5}{2} - 7 - \frac{\sqrt{2}}{2} = \\ = \frac{5 - 14 - \sqrt{2}}{2} = -\frac{9 + \sqrt{2}}{2}.$$

Javob:  $-\frac{9 + \sqrt{2}}{2}$ .

2-misol.  $(2 \operatorname{tg} \frac{\pi}{6} - \operatorname{tg} \frac{\pi}{3}) : \cos \frac{\pi}{6} + \sin \frac{\pi}{4}$  ning qiymati

$2 \sin \frac{\pi}{4} + \sqrt{2} \cos \frac{\pi}{4}$  ning qiymatidan qanchaga kam?

1-jadval

$\alpha$	0	$\frac{\pi}{6}$	$\frac{\pi}{4}$	$\frac{\pi}{3}$	$\frac{\pi}{2}$	$\pi$	$\frac{3}{2}\pi$	$2\pi$
	$0^\circ$	$30^\circ$	$45^\circ$	$60^\circ$	$90^\circ$	$180^\circ$	$270^\circ$	$360^\circ$
$\sin \alpha$	0	$\frac{1}{2}$	$\frac{\sqrt{2}}{2}$	$\frac{\sqrt{3}}{2}$	1	0	-1	0
$\cos \alpha$	1	$\frac{\sqrt{3}}{2}$	$\frac{\sqrt{2}}{2}$	$\frac{1}{2}$	0	-1	0	1
$\operatorname{tg} \alpha$	0	$\frac{1}{\sqrt{3}}$	1	$\sqrt{3}$	mavjud emas	0	mavjud emas	0
$\operatorname{ctg} \alpha$	mavjud emas	$\sqrt{3}$	1	$\frac{1}{\sqrt{3}}$	0	mavjud emas	0	mavjud emas



Yechilishi. Berilgan ifodalarning qiymatlarini hisoblaymiz:

$$1) \left( 2 \operatorname{tg} \frac{\pi}{6} - \operatorname{tg} \frac{\pi}{3} \right) : \cos \frac{\pi}{6} + \sin \frac{\pi}{4} = \left( 2 \cdot \frac{1}{\sqrt{3}} - \sqrt{3} \right) : \frac{\sqrt{3}}{2} + \frac{\sqrt{2}}{2} = \frac{2-3}{\sqrt{3}} \cdot \frac{2}{\sqrt{3}} + \frac{\sqrt{2}}{2} = -\frac{2}{3} + \frac{\sqrt{2}}{2};$$

$$2) 2 \sin \frac{\pi}{4} + \sqrt{2} \cos \frac{\pi}{4} = 2 \cdot \frac{\sqrt{2}}{2} + \sqrt{2} \cdot \frac{\sqrt{2}}{2} = \sqrt{2} + 1.$$

3) Ikkinchi ifoda qiymatidan birinchi ifoda qiymatini ayiramiz:

$$\sqrt{2} + 1 - \left( -\frac{2}{3} + \frac{\sqrt{2}}{2} \right) = \sqrt{2} + 1 + \frac{2}{3} - \frac{\sqrt{2}}{2} = \frac{\sqrt{2}}{2} + \frac{5}{3}.$$

Javob:  $\frac{\sqrt{2}}{2} + \frac{5}{3}$  ga kam.

### 3-§. Sinus, kosinus, tangens va kotangensning ishoralari

$\sin \alpha$  va  $\cos \alpha$  ning ishoralari birlik aylananing  $P_\alpha$  nuqtasining  $y_\alpha$  ordinatasi va  $x_\alpha$  absissasi ishoralari bilan aniqlanadi. Birinchi chorakda joylashgan nuqtalarning ordinalari va absissalari musbat. Shu sababli, agar  $0 < \alpha < \frac{\pi}{2}$  bo'lsa,  $\sin \alpha > 0$  va  $\cos \alpha > 0$  bo'ladi (112-rasm). Ikkinchi chorakda joylashgan nuqtalar uchun ordinalar musbat, absissalar esa manfiy. Shuning uchun, agar  $\frac{\pi}{2} < \alpha < \pi$  bo'lsa,  $\sin \alpha > 0$ ,  $\cos \alpha < 0$  bo'ladi. (113-rasm). Shunga

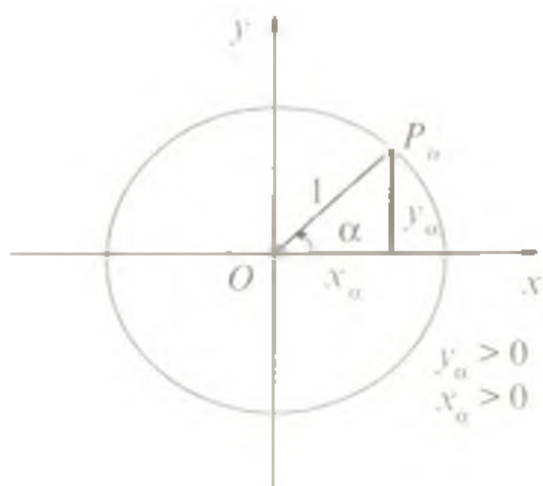

112-rasm

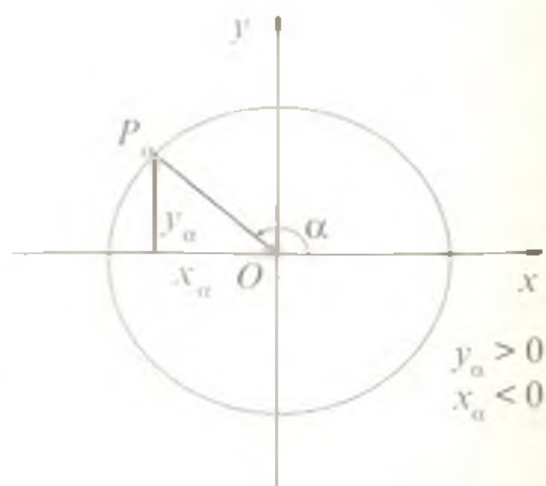

113-rasm



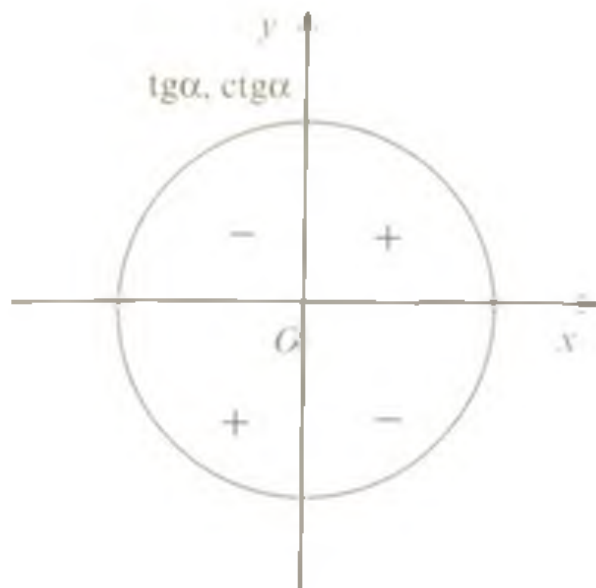

117-rasm

1-misol.  $\sin 150^\circ \cdot \cos 100^\circ \cdot \operatorname{tg} 230^\circ \cdot \operatorname{ctg} 4^\circ$  ko'paytma ishorasini aniqlang.

Yechilishi.  $90^\circ < 150^\circ < 180^\circ$  bo'lganligi uchun  $\sin 150^\circ > 0$ ;  $90^\circ < 100^\circ < 180^\circ$  bo'lganligi uchun  $\cos 100^\circ < 0$ ;  $180^\circ < 230^\circ < 270^\circ$  bo'lganligi uchun  $\operatorname{tg} 230^\circ > 0$ ;  $\pi < 4 < \frac{3\pi}{2}$  bo'lganligi uchun  $\operatorname{ctg} 4^\circ > 0$ . Demak, berilgan ko'paytmaning ishorasi manfiy.

Javob:  $\sin 150^\circ \cdot \cos 100^\circ \cdot \operatorname{tg} 230^\circ \cdot \operatorname{ctg} 4^\circ < 0$ .

2-misol. Agar  $270^\circ < \alpha < 360^\circ$  bo'lsa,  $\operatorname{tg}^3 \alpha \cdot \sin \alpha \cdot \sec^2 \alpha$  ko'paytmaning ishorasini toping.

Yechilishi. Ko'rsatilgan oraliqda, ya'ni IV chorakda  $\operatorname{tg} \alpha < 0$ ,  $\sin \alpha < 0$ ,  $\sec \alpha > 0$  bo'lganligidan  $\operatorname{tg}^3 \alpha \cdot \sin \alpha \cdot \sec^2 \alpha > 0$ .

Javob. Ko'paytma musbat.

3-misol.  $a = \frac{\sin 4^\circ}{\cos 100^\circ}$ ;  $b = \frac{\operatorname{tg} 114^\circ}{\cos 280^\circ}$ ;  $c = \frac{\sec 300^\circ}{\operatorname{ctg} 200^\circ}$  sonlaridan qaysi biri manfiy?

Yechilishi: 1)  $180^\circ < 4^\circ < 270^\circ$ ;  $90^\circ < 100^\circ < 180^\circ$  bo'lganligi uchun  $\sin 4^\circ < 0$ ,  $\cos 100^\circ < 0$ , demak,  $a > 0$ ;

2)  $90^\circ < 114^\circ < 180^\circ$ ;  $270^\circ < 280^\circ < 360^\circ$  bo'lganligi uchun  $\operatorname{tg} 114^\circ < 0$ ;  $\cos 280^\circ > 0$ , demak,  $b < 0$ ;

3)  $270^\circ < 300^\circ < 360^\circ$ ;  $180^\circ < 200^\circ < 270^\circ$  bo'lganligi uchun  $\sec 300^\circ > 0$ ,  $\operatorname{ctg} 200^\circ > 0$ , demak,  $c > 0$ ;

Javob:  $b$ .

#### 4-§. Asosiy trigonometrik ayniyatlar

4.1. Asosiy ayniyat. Birlik aylana ixtiyoriy  $P_\alpha(x_\alpha; y_\alpha)$  nuqtasining koordinatalari

$$x^2 + y^2 = 1$$

tenglamani qanoatlantiradi (katetlari  $|x_\alpha|$  va  $|y_\alpha|$ , gipotenuzasi 1 ga teng bo'lgan to'g'ri burchakli uchburchak uchun Pifagor teoremasiga ko'ra; 111-rasmga qarang). Demak,

$$\sin^2 \alpha + \cos^2 \alpha = 1. \quad (1)$$

(1) tenglik  $\alpha$  ning istalgan qiymatida bajariladi va *asosiy trigonometrik ayniyat* deyiladi.

Bu tenglikdan  $\sin \alpha$  ni  $\cos \alpha$  va aksincha  $\cos \alpha$  ni  $\sin \alpha$  orqali ifodalash mumkin:

$$\sin \alpha = \pm \sqrt{1 - \cos^2 \alpha}, \quad (2)$$

$$\cos \alpha = \pm \sqrt{1 - \sin^2 \alpha}. \quad (3)$$

(2), (3) formulalarda ildiz oldidagi ishora formulaning chap qismidagi ifoda ishorasi bilan aniqlanadi.

1-masala. Agar  $\sin \alpha = \frac{1}{4}$  va  $-\frac{\pi}{2} < \alpha < 0$  bo'lsa,  $\cos \alpha$  ning qiymatini hisoblang.

Yechilishi.  $-\frac{\pi}{2} < \alpha < 0$  bo'lgani uchun  $\cos \alpha > 0$  bo'ladi. Shu sababli

$$\cos \alpha = \sqrt{1 - \sin^2 \alpha} = \sqrt{1 - \frac{1}{16}} = \frac{\sqrt{15}}{4}.$$

Javob:  $\frac{\sqrt{15}}{4}$ .

**4.2. Ayni bir burchakning sinusi, kosinusi, tangensi va kotangensi orasidagi munosabatlar.** Tangens va kotangensning ta'riflanishiga ko'ra

$$\operatorname{tg} \alpha = \frac{\sin \alpha}{\cos \alpha}, \quad \operatorname{ctg} \alpha = \frac{\cos \alpha}{\sin \alpha}.$$

Bu tengliklarni ko'paytirib,

$$\operatorname{tg} \alpha \cdot \operatorname{ctg} \alpha = 1, \quad \sin \alpha \neq 0, \quad \cos \alpha \neq 0. \quad (4)$$

tenglikni hosil qilamiz. (4) dan

$$\operatorname{tg} \alpha = \frac{1}{\operatorname{ctg} \alpha}, \quad \sin \alpha \neq 0, \quad \cos \alpha \neq 0; \quad (5)$$

$$\operatorname{ctg} \alpha = \frac{1}{\operatorname{tg} \alpha}, \quad \sin \alpha \neq 0, \quad \cos \alpha \neq 0. \quad (6)$$

(1) ayniyatda uning har ikkala qismining  $\cos^2 \alpha$  ga bo'lib,

$$1 + \operatorname{tg}^2 \alpha = \frac{1}{\cos^2 \alpha}, \quad (\cos \alpha \neq 0) \quad (7)$$

tenglikni hosil qilamiz.

Shunga o'xshash, (1) ning har ikkala qismini  $\sin^2 \alpha$  ga bo'lib,

$$1 + \operatorname{ctg}^2 \alpha = \frac{1}{\sin^2 \alpha}, \quad (\sin \alpha \neq 0) \quad (8)$$

tenglikni hosil qilamiz.

(7) formuladan tangensni kosinus va kosinusni tangens orqali ifodalash mumkin:

$$\operatorname{tg} \alpha = \pm \frac{\sqrt{1 - \cos^2 \alpha}}{\cos \alpha}; \quad \cos \alpha = \pm \frac{1}{\sqrt{1 + \operatorname{tg}^2 \alpha}}$$

Shunga o'xshash, (8) formuladan kotangens sinus orqali, sinus kotangens orqali ifodalanadi:

$$\operatorname{ctg} \alpha = \pm \frac{\sqrt{1 - \sin^2 \alpha}}{\sin \alpha}; \quad \sin \alpha = \pm \frac{1}{\sqrt{1 + \operatorname{ctg}^2 \alpha}}$$

2-masala. Agar  $\cos \alpha = -0,8$  va  $\frac{\pi}{2} < \alpha < \pi$  bo'lsa,  $\sin \alpha$ ,  $\operatorname{tg} \alpha$ ,  $\operatorname{ctg} \alpha$  ning qiymatlarini hisoblang.

Yechilishi. Ikkinchi chorakda sinus musbat bo'lganligi uchun, (2) formulaga ko'ra

$$\sin \alpha = \sqrt{1 - \cos^2 \alpha} = \sqrt{1 - 0,64} = \sqrt{0,36} = 0,6,$$

$$\operatorname{tg} \alpha = \frac{\sin \alpha}{\cos \alpha} = -\frac{0,6}{0,8} = -\frac{3}{4} = -0,75,$$

$$\operatorname{ctg} \alpha = \frac{1}{\operatorname{tg} \alpha} = -\frac{4}{3} = -1,33.$$

Javob: 0,6; -0,75; -1,33.

3-masala.  $\frac{\sin^2 \alpha - \operatorname{tg}^2 \alpha}{\cos^2 \alpha - \operatorname{ctg}^2 \alpha}$  ifodani soddalashtirib, uning  $\alpha = \frac{\pi}{3}$

dagi qiymatini hisoblang.

Yechilishi. Bundan buyon masala-misollarda berilgan ifodalar o'zgaruvchining qabul qilishi mumkin bo'lgan qiymatlarida o'rinli deb faraz qilamiz.

Ifodani oldin soddalashtirib, keyin tegishli son qiymatini hisoblaymiz.

$$\begin{aligned} 1) \quad \frac{\sin^2 \alpha - \operatorname{tg}^2 \alpha}{\cos^2 \alpha - \operatorname{ctg}^2 \alpha} &= \frac{\sin^2 \alpha \cdot \cos^2 \alpha - \sin^2 \alpha}{\cos^2 \alpha} \cdot \frac{\sin^2 \alpha}{\cos^2 \alpha \cdot \sin^2 \alpha - \cos^2 \alpha} = \\ &= \frac{\sin^4 \alpha \cdot \cos^2 \alpha - \sin^2 \alpha}{\cos^4 \alpha \cdot \sin^2 \alpha - \cos^2 \alpha} = \frac{\sin^4 \alpha \cdot (-\sin^2 \alpha)}{\cos^4 \alpha \cdot (-\cos^2 \alpha)} = \frac{\sin^6 \alpha}{\cos^6 \alpha} = \operatorname{tg}^6 \alpha. \end{aligned}$$

2)  $\operatorname{tg}^6 \alpha$  ni  $\alpha = \frac{\pi}{3}$  dagi qiymatini hisoblaymiz:

$$\operatorname{tg}^6 \frac{\pi}{3} = (\sqrt{3})^6 = \left(3^{\frac{1}{2}}\right)^6 = 3^3 = 27.$$

Javob: 27.

4-masala. Agar  $\sin\alpha + \cos\alpha = k$  ekanligi ma'lum bo'lsa,  $\sin^3\alpha + \cos^3\alpha$  ni toping.

Yechilishi.  $\sin^3\alpha + \cos^3\alpha$  ni ikki son kublarining yig'indisi sifatida ko'paytuvchilarga ajratamiz:

$$\sin^3\alpha + \cos^3\alpha = (\sin\alpha + \cos\alpha)(\sin^2\alpha - \sin\alpha\cos\alpha + \cos^2\alpha).$$

Bu ifodada  $\sin\alpha + \cos\alpha$  masala shartiga ko'ra  $k$  ga teng va  $\sin^2\alpha + \cos^2\alpha = 1$  (asosiy trigonometrik ayniyat);  $\sin\alpha \cos\alpha$  ko'paytmani masala shartidagi  $\sin\alpha + \cos\alpha = k$  tenglikning har ikkala qismini kvadratga oshirib topish mumkin:

$$\begin{aligned} \sin\alpha + \cos\alpha = k &\Leftrightarrow (\sin\alpha + \cos\alpha)^2 = k^2 \Leftrightarrow \sin^2\alpha + 2\sin\alpha\cos\alpha + \cos^2\alpha = \\ &= k^2 \Leftrightarrow \sin\alpha\cos\alpha = \frac{k^2 - 1}{2}. \text{ Shunday qilib,} \end{aligned}$$

$$\sin^3\alpha + \cos^3\alpha = k \cdot \left(1 - \frac{k^2 - 1}{2}\right) = \frac{k(3 - k^2)}{2}.$$

Javob:  $\frac{k(3 - k^2)}{2}$ .

5-masala.  $\operatorname{tg}^2\alpha - \sin^2\alpha = \operatorname{tg}^2\alpha \sin^2\alpha$  ayniyatni isbotlang.

Isboti. Bu ayniyatni isbotlash uchun tenglikning o'ng qismida

$\operatorname{tg}^2\alpha = \frac{\sin^2\alpha}{\cos^2\alpha}$  tenglikdan foydalanib, tegishli shakl almashtirishlarni

bajaramiz:

$$\begin{aligned} \operatorname{tg}^2\alpha - \sin^2\alpha &= \frac{\sin^2\alpha}{\cos^2\alpha} - \sin^2\alpha = \frac{\sin^2\alpha - \sin^2\alpha \cos^2\alpha}{\cos^2\alpha} = \frac{\sin^2\alpha(1 - \cos^2\alpha)}{\cos^2\alpha} = \\ &= \frac{\sin^2\alpha \sin^2\alpha}{\cos^2\alpha} = \operatorname{tg}^2\alpha \sin^2\alpha. \end{aligned}$$

Ayniyat isbotlandi.

6-masala.  $\frac{\sin\alpha}{1 - \cos\alpha} = \frac{1 + \cos\alpha}{\sin\alpha}$  ayniyatni isbotlang.

Isboti. Berilgan ayniyatni isbotlash uchun uning chap va o'ng qismlarining ayirmasi nolga teng ekanligini ko'rsatish kifoya:

$$\frac{\sin\alpha}{1 - \cos\alpha} - \frac{1 + \cos\alpha}{\sin\alpha} = \frac{\sin^2\alpha - 1 + \cos^2\alpha}{\sin\alpha(1 - \cos\alpha)} = \frac{1 - 1}{\sin\alpha(1 - \cos\alpha)} = 0.$$

Ayniyat isbotlandi.

## 5-§. Keltirish formulalari

Argumentlari  $\frac{k\pi}{2} \pm \alpha$ ,  $k \in Z$  ko'rinishidagi trigonometrik funksiyalarni  $\alpha$  argumentning trigonometrik funksiyalariga keltiruvchi formulalar keltirish formulalari deyiladi. Xususan, 2-jadvalda argumentlari  $\frac{\pi}{2} \pm \alpha$ ,  $\pi \pm \alpha$ ,  $\frac{3\pi}{2} \pm \alpha$ ,  $2\pi \pm \alpha$  bo'lgan trigonometrik funksiyalarning qiymatlarini  $\sin \alpha$ ,  $\cos \alpha$ ,  $\operatorname{tg} \alpha$  va  $\operatorname{ctg} \alpha$  trigonometrik funksiyalar qiymatlari bilan bog'lovchi keltirish formulalari berilgan.

2-jadval

funksiya	Burchak							
	$\frac{\pi}{2} - \alpha$	$\frac{\pi}{2} + \alpha$	$\pi - \alpha$	$\pi + \alpha$	$\frac{3\pi}{2} - \alpha$	$\frac{3\pi}{2} + \alpha$	$2\pi - \alpha$	$2\pi + \alpha$
$\sin \alpha$	$\cos \alpha$	$\cos \alpha$	$\sin \alpha$	$-\sin \alpha$	$-\cos \alpha$	$-\cos \alpha$	$-\sin \alpha$	$\sin \alpha$
$\cos \alpha$	$\sin \alpha$	$-\sin \alpha$	$-\cos \alpha$	$-\cos \alpha$	$-\sin \alpha$	$\sin \alpha$	$\cos \alpha$	$\cos \alpha$
$\operatorname{tg} \alpha$	$\operatorname{ctg} \alpha$	$-\operatorname{ctg} \alpha$	$-\operatorname{tg} \alpha$	$\operatorname{tg} \alpha$	$\operatorname{ctg} \alpha$	$-\operatorname{ctg} \alpha$	$-\operatorname{tg} \alpha$	$\operatorname{tg} \alpha$
$\operatorname{ctg} \alpha$	$\operatorname{tg} \alpha$	$-\operatorname{tg} \alpha$	$-\operatorname{ctg} \alpha$	$\operatorname{ctg} \alpha$	$\operatorname{tg} \alpha$	$-\operatorname{tg} \alpha$	$-\operatorname{ctg} \alpha$	$\operatorname{ctg} \alpha$

Ushbu qoidalar yodda qolsa, keltirish formulalarini eslash osonlashadi.

1)  $\frac{\pi}{2} \pm \alpha$ ,  $\frac{3\pi}{2} \pm \alpha$  burchaklar funksiyalaridan  $\alpha$  burchak funksiyalariga o'tilayotganda funksiyaning nomi sinusdan kosinusga, kosinusdan sinusga, tangensdan kotangensga, kotangensdan tangensga o'zgaradi;

2)  $\pi \pm \alpha$ ,  $2\pi \pm \alpha$  burchaklar funksiyalaridan  $\alpha$  burchak funksiyalariga o'tilayotganda funksiyaning nomi saqlanadi;

3)  $\alpha$  ni o'tkir burchak deb hisoblab (ya'ni  $0 < \alpha < \frac{\pi}{2}$ ),  $\alpha$  burchak

funksiyasi oldiga  $\frac{\pi}{2} \pm \alpha$ ,  $\frac{3\pi}{2} \pm \alpha$ ,  $\pi \pm \alpha$ ,  $2\pi \pm \alpha$  burchaklarning keltirilayotgan funksiyalarining ishorasi qo'yiladi.

Masalan,  $\operatorname{ctg}\left(\frac{\pi}{2} + \alpha\right)$  ni aniqlash kerak bo'lsin. Bilamizki,

1) qoidaga ko'ra formulaning o'ng qismida  $\operatorname{tg} \alpha$  turishi kerak.  $\operatorname{tg} \alpha$  oldidagi ishorani aniqlash uchun  $\alpha$  ni o'tkir burchak deb faraz qilamiz. U holda  $\frac{\pi}{2} + \alpha$  burchak 2-chorakda tugashi kerak. 2-chorakda tugaydigan burchakning kotangensi manfiy. Shuning uchun  $\operatorname{tg} \alpha$  oldidagi ishora manfiy. Demak,

$$\operatorname{ctg}\left(\frac{\pi}{2} + \alpha\right) = -\operatorname{tg}\alpha$$

Shunga o'xshash.

$$\cos(2\pi - \alpha) = \cos \alpha$$

formulani ham o'rinli ekanligiga ishonch hosil qilish mumkin. 2) qoidaga ko'ra funksiyaning nomi o'zgarmaydi. O'tkir burchak bo'lsa, burchak to'rtinchi chorakda tugaydi. Lekin to'rtinchi chorakda tugaydigan burchakning kosinusi musbat. Shuning uchun formulaning o'ng qismida + ishora turadi.

Keltirish formulalaridan foydalanib yechiladigan bir necha misollar qaraymiz.

1-misol.  $\operatorname{tg} 1800^\circ - \sin 495^\circ + \cos 945^\circ$  ifodaning son qiymatini toping.

$$\begin{aligned} \text{Yechilishi. } & \operatorname{tg} 1800^\circ - \sin 495^\circ + \cos 945^\circ = \operatorname{tg} 10\pi - \sin(3\pi - 45^\circ) + \\ & + \cos\left(\frac{11\pi}{2} - 45^\circ\right) = 0 - \sin 45^\circ - \sin 45^\circ = -\frac{\sqrt{2}}{2} - \frac{\sqrt{2}}{2} = -\sqrt{2}. \end{aligned}$$

$$\text{Javob: } -\sqrt{2}.$$

2-misol.  $\operatorname{tg} 18^\circ \operatorname{tg} 288^\circ + \sin 32^\circ \sin 148^\circ - \sin 302^\circ \sin 122^\circ$  ni hisoblang.

$$\begin{aligned} \text{Yechilishi. } & \operatorname{tg} 18^\circ \operatorname{tg} 288^\circ + \sin 32^\circ \sin 148^\circ - \sin 302^\circ \sin 122^\circ = \\ & = \operatorname{tg} 18^\circ \cdot \operatorname{tg}\left(\frac{3\pi}{2} + 18^\circ\right) + \sin 32^\circ \sin(\pi - 32^\circ) - \sin\left(\frac{3\pi}{2} + 32^\circ\right) \sin\left(\frac{\pi}{2} + 32^\circ\right) = \\ & = \operatorname{tg} 18^\circ \cdot (-\operatorname{ctg} 18^\circ) + \sin 32^\circ \cdot \sin 32^\circ + \cos 32^\circ \cos 32^\circ = -\operatorname{tg} 18^\circ \cdot \operatorname{ctg} 18^\circ + \\ & + \sin^2 32^\circ + \cos^2 32^\circ = -1 + 1 = 0. \end{aligned}$$

$$\text{Javob: } 0.$$

3-misol.  $\frac{\cos(\alpha - 90^\circ)}{\sin(180^\circ - \alpha)} + \frac{\operatorname{tg}(\alpha - 180^\circ) \cos(180^\circ + \alpha) \sin(270^\circ + \alpha)}{\operatorname{tg}(270^\circ + \alpha)}$  ifodani soddalashtiring.

$$\begin{aligned} \text{Yechilishi. } & \frac{\cos(\alpha - 90^\circ)}{\sin(180^\circ - \alpha)} + \frac{\operatorname{tg}(\alpha - 180^\circ) \cos(180^\circ + \alpha) \sin(270^\circ + \alpha)}{\operatorname{tg}(270^\circ + \alpha)} = \\ & = \frac{\cos(-90^\circ - \alpha)}{\sin \alpha} + \frac{\operatorname{tg}(-180^\circ - \alpha) \cdot (-\cos \alpha) \cdot (-\cos \alpha)}{-\operatorname{ctg} \alpha} = \\ & = \frac{\sin \alpha}{\sin \alpha} + \frac{\operatorname{tg} \alpha \cos^2 \alpha}{-\operatorname{ctg} \alpha} = 1 - \operatorname{tg} \alpha \cdot \frac{1}{\operatorname{ctg} \alpha} \cdot \cos^2 \alpha = 1 - \sin^2 \alpha = \cos^2 \alpha. \end{aligned}$$

$$\text{Javob: } \cos^2 \alpha.$$



## 6-§. Asosiy trigonometrik formulalar

**6.1. Qo'shish formulalari.** Istalgan  $\alpha$  va  $\beta$  sonlar uchun quyidagi formulalar o'rinlidir:

$$\cos(\alpha + \beta) = \cos\alpha \cdot \cos\beta - \sin\alpha \cdot \sin\beta \quad (1)$$

$$\cos(\alpha - \beta) = \cos\alpha \cdot \cos\beta + \sin\alpha \cdot \sin\beta \quad (2)$$

$$\sin(\alpha + \beta) = \sin\alpha \cdot \cos\beta + \cos\alpha \cdot \sin\beta \quad (3)$$

$$\sin(\alpha - \beta) = \sin\alpha \cdot \cos\beta - \cos\alpha \cdot \sin\beta \quad (4)$$

$\alpha$  va  $\beta$  ning hamda  $\alpha + \beta$  ning  $\frac{\pi}{2} + k\pi$ , ( $k \in Z$ ) dan boshqa barcha qiymatlari uchun

$$\operatorname{tg}(\alpha + \beta) = \frac{\operatorname{tg}\alpha + \operatorname{tg}\beta}{1 - \operatorname{tg}\alpha \operatorname{tg}\beta} \quad (5)$$

formula,  $\alpha$  va  $\beta$  ning hamda  $\alpha - \beta$  ning  $\frac{\pi}{2} + k\pi$ , ( $k \in Z$ ) dan boshqa barcha qiymatlari uchun

$$\operatorname{tg}(\alpha - \beta) = \frac{\operatorname{tg}\alpha - \operatorname{tg}\beta}{1 + \operatorname{tg}\alpha \operatorname{tg}\beta} \quad (6)$$

formulalar o'rinlidir.

1-misol.  $\cos 105^\circ$  ni hisoblang.

Yechilishi:  $105^\circ$  ni  $60^\circ + 45^\circ$  yig'indi ko'rinishda yozib, (1) formuladan foydalanamiz.

$$\begin{aligned} \cos 105^\circ &= \cos(60^\circ + 45^\circ) = \cos 60^\circ \cdot \cos 45^\circ - \sin 60^\circ \cdot \sin 45^\circ = \\ &= \frac{1}{2} \cdot \frac{\sqrt{2}}{2} - \frac{\sqrt{3}}{2} \cdot \frac{\sqrt{2}}{2} = \frac{\sqrt{2}}{4} (1 - \sqrt{3}). \end{aligned}$$

$$\text{Javob: } \frac{\sqrt{2}}{4} (1 - \sqrt{3}).$$

2-misol. Agar  $\sin \alpha = \frac{9}{41}$ ,  $\sin \beta = -\frac{40}{41}$ ,  $\frac{\pi}{2} < \alpha < \pi$ ,  $\frac{3\pi}{2} < \beta < 2\pi$ , bo'lsa,  $\sin(\alpha + \beta)$  ning qiymatini toping.

Yechilishi: 1)  $P_\alpha$  nuqta ikkinchi chorakka,  $P_\beta$  nuqta to'rtinchi chorakka tegishli ekanligini hisobga olib,  $\cos \alpha$  va  $\cos \beta$  larning qiymatlarini topamiz:

$$\cos \alpha = -\sqrt{1 - \sin^2 \alpha} = -\sqrt{1 - \frac{81}{1681}} = -\frac{40}{41};$$

$$\cos \beta = \sqrt{1 - \sin^2 \beta} = \sqrt{1 - \frac{1600}{1681}} = \frac{9}{41}.$$

2) (3) formuladan foydalanib  $\sin(\alpha + \beta)$  ning qiymatini hisoblaymiz:

$$\sin(\alpha + \beta) = \sin \alpha \cos \beta + \cos \alpha \sin \beta = \frac{9}{41} \cdot \frac{9}{41} + \frac{40}{41} \cdot \frac{40}{41} = \frac{81+1600}{1681} = 1.$$

Javob: 1.

3-misol. Agar  $\alpha + \beta + \gamma = \frac{\pi}{2}$  bo'lsa,  $\operatorname{tg}\alpha\operatorname{tg}\beta + \operatorname{tg}\beta\operatorname{tg}\gamma + \operatorname{tg}\alpha\operatorname{tg}\gamma$  ning qiymatini hisoblang.

Yechilishi. Masala shartidan  $\gamma = \frac{\pi}{2} - (\alpha + \beta)$  ekanligini hisobga olib, tegishli shakl almashtirishlarni bajaramiz:

$$\begin{aligned} \operatorname{tg}\alpha\operatorname{tg}\beta + \operatorname{tg}\beta\operatorname{tg}\gamma + \operatorname{tg}\alpha\operatorname{tg}\gamma &= \operatorname{tg}\alpha\operatorname{tg}\beta + \operatorname{tg}\gamma(\operatorname{tg}\alpha + \operatorname{tg}\beta) = \operatorname{tg}\alpha\operatorname{tg}\beta + \\ + \operatorname{tg}\left(\frac{\pi}{2} - (\alpha + \beta)\right)(\operatorname{tg}\alpha + \operatorname{tg}\beta) &= \operatorname{tg}\alpha\operatorname{tg}\beta + \operatorname{ctg}(\alpha + \beta)(\operatorname{tg}\alpha + \operatorname{tg}\beta) = \operatorname{tg}\alpha\operatorname{tg}\beta + \\ + \frac{1 - \operatorname{tg}\alpha\operatorname{tg}\beta}{\operatorname{tg}\alpha + \operatorname{tg}\beta} \cdot (\operatorname{tg}\alpha + \operatorname{tg}\beta) &= \operatorname{tg}\alpha\operatorname{tg}\beta + 1 - \operatorname{tg}\alpha\operatorname{tg}\beta = 1. \end{aligned}$$

Javob: 1.

**6.2. Ikkilangan va yarimburchak formulalari.** Agar (1), (3) va (5) formulalarda  $\alpha = \beta$  desak, *ikkilangan burchak formulalari* deb ataluvchi

$$\cos 2\alpha = \cos^2 \alpha - \sin^2 \alpha; \quad (7)$$

$$\sin 2\alpha = 2 \sin \alpha \cos \alpha; \quad (8)$$

$$\operatorname{tg} 2\alpha = \frac{2 \operatorname{tg} \alpha}{1 - \operatorname{tg}^2 \alpha} \quad (9)$$

formulalarga ega bo'lamiz. (7) va (8) formulalar istalgan  $\alpha$  uchun o'rinli bo'lsa, (9) formula  $\alpha \neq \frac{\pi}{4} + \frac{k\pi}{2}$  ( $k \in Z$ ) va  $\alpha \neq \frac{\pi}{2} + \pi k$  ( $k \in Z$ ) larda o'rinlidir.

(7) formulaning o'ng tomonini faqat sinus yoki kosinus orqali ifodalab, quyidagi munosabatlarga ega bo'lamiz:

$$\cos 2\alpha = 1 - 2 \sin^2 \alpha; \quad \cos 2\alpha = 2 \cos^2 \alpha - 1. \quad (10)$$

(10) formulalardan trigonometrik ifodalarda shakl almashtirishlar bajarilishida keng qo'llaniladigan *darajani pasaytirish formulalari* deb ataluvchi

$$\sin^2 \alpha = \frac{1 - \cos 2\alpha}{2}; \quad \cos^2 \alpha = \frac{1 + \cos 2\alpha}{2} \quad (11)$$

formulalar kelib chiqadi.

Bulardan tashqari, *uchlangan burchakning sinusi, kosinusi va tangensi* uchun

$$\sin 3\alpha = 3 \sin \alpha - 4 \sin^3 \alpha, \quad \cos 3\alpha = 4 \cos^3 \alpha - 3 \cos \alpha. \quad (12)$$

$$\operatorname{tg} 3\alpha = \frac{3\operatorname{tg}\alpha - \operatorname{tg}^3\alpha}{1 - 3\operatorname{tg}^2\alpha} \quad (13)$$

formulalarni ham bilish foydalidir. (13) da

$$\alpha \neq \frac{\pi}{2} + k\pi \quad (k \in Z) \text{ va } \alpha \neq \frac{\pi}{6} + n\pi \quad (k \in Z).$$

(11) formulalarda  $\alpha = \frac{x}{2}$  desak, yarim burchaklar formulalari hosil bo'ladi:

$$\sin \frac{x}{2} = \pm \sqrt{\frac{1 - \cos x}{2}}; \quad (14)$$

$$\cos \frac{x}{2} = \pm \sqrt{\frac{1 + \cos x}{2}}. \quad (15)$$

(14) va (15) ni hadma-had bo'lsak, tangens uchun yarim burchak formulasi

$$\operatorname{tg} \frac{x}{2} = \pm \sqrt{\frac{1 - \cos x}{1 + \cos x}} = \frac{1 - \cos x}{\sin x} \quad (16)$$

kelib chiqadi. Bunda  $x \neq \pi + 2k\pi \quad (k \in Z)$ .

4-misol.  $\sin \frac{\pi}{12} \cos \frac{\pi}{12} + \left( \sin^2 \frac{\pi}{8} - \cos^2 \frac{\pi}{8} \right)^2$  ifodani soddalashtiring.

$$\begin{aligned} \text{Yechilishi. } & \sin \frac{\pi}{12} \cos \frac{\pi}{12} + \left( \sin^2 \frac{\pi}{8} - \cos^2 \frac{\pi}{8} \right)^2 = \frac{1}{2} \cdot 2 \sin \frac{\pi}{12} \cos \frac{\pi}{12} + \\ & + \left( -\left( \cos^2 \frac{\pi}{8} - \sin^2 \frac{\pi}{8} \right) \right)^2 = \frac{1}{2} \sin \frac{\pi}{6} + \cos^2 \frac{\pi}{4} = \frac{1}{2} \cdot \frac{1}{2} + \left( \frac{\sqrt{2}}{2} \right)^2 = \frac{1}{4} + \frac{1}{2} = \frac{3}{4}. \end{aligned}$$

Javob:  $\frac{3}{4}$ .

5-misol.  $\sin 10^\circ \sin 50^\circ \sin 70^\circ$  ning qiymatini hisoblang.

$$\begin{aligned} \text{Yechilishi. } & \sin 10^\circ \sin 50^\circ \sin 70^\circ = \frac{2 \cos 10^\circ \sin 10^\circ \sin 50^\circ \sin 70^\circ}{2 \cos 10^\circ} = \\ & = \frac{\sin 20^\circ \sin 50^\circ \sin \left( \frac{\pi}{2} - 20^\circ \right)}{2 \cos 10^\circ} = \frac{2 \sin 20^\circ \cos 20^\circ \sin 50^\circ}{4 \cos 10^\circ} = \frac{\sin 40^\circ \sin 50^\circ}{4 \cos 10^\circ} = \\ & = \frac{\sin 40^\circ \sin \left( \frac{\pi}{2} - 40^\circ \right)}{4 \cos 10^\circ} = \frac{\sin 40^\circ \cos 40^\circ}{4 \cos 10^\circ} = \frac{\sin 80^\circ}{8 \cos 10^\circ} = \frac{\sin \left( \frac{\pi}{2} - 10^\circ \right)}{8 \cos 10^\circ} = \frac{\cos 10^\circ}{8 \cos 10^\circ} = \frac{1}{8}. \end{aligned}$$

Javob:  $\frac{1}{8}$ .

6-misol. Agar  $\sin \alpha = 0,8$  va  $0^\circ < \alpha < 90^\circ$  bo'lsa,  $\cos 2\alpha$  ning qiymatini hisoblang.

Yechilishi. Burchak I chorakka tegishli ekanligini hisobga olib,  $\cos \alpha$  ning qiymatini topamiz:

$$\cos \alpha = \sqrt{1 - \sin^2 \alpha} = \sqrt{1 - 0,64} = \sqrt{0,36} = 0,6.$$

(7) formuladan

$$\cos 2\alpha = (0,6)^2 - (0,8)^2 = 0,36 - 0,64 = -0,28.$$

Javob:  $-0,28$ .

7-misol.  $\frac{\sin \alpha + \sin \frac{\alpha}{2}}{1 + \cos \alpha + \cos \frac{\alpha}{2}}$  ifodani soddalashtiring.

Yechilishi. Ifodani soddalashtirishda  $\sin \alpha = 2 \sin \frac{\alpha}{2} \cos \frac{\alpha}{2}$  va  $1 + \cos \alpha = 2 \cos^2 \frac{\alpha}{2}$  munosabatlardan foydalanamiz. U holda

$$\frac{\sin \alpha + \sin \frac{\alpha}{2}}{1 + \cos \alpha + \cos \frac{\alpha}{2}} = \frac{2 \sin \frac{\alpha}{2} \cos \frac{\alpha}{2} + \sin \frac{\alpha}{2}}{2 \cos^2 \frac{\alpha}{2} + \cos \frac{\alpha}{2}} = \frac{\sin \frac{\alpha}{2} (2 \cos \frac{\alpha}{2} + 1)}{\cos \frac{\alpha}{2} (2 \cos \frac{\alpha}{2} + 1)} = \operatorname{tg} \frac{\alpha}{2}.$$

Javob:  $\operatorname{tg} \frac{\alpha}{2}$ .

8-misol.  $\cos 15^\circ$  ni hisoblang.

$$\text{Yechilishi: } \cos 15^\circ = \cos \frac{30^\circ}{2} = \sqrt{\frac{1 + \cos 30^\circ}{2}} = \sqrt{\frac{1 + \frac{\sqrt{3}}{2}}{2}} = \frac{\sqrt{2 + \sqrt{3}}}{2}.$$

Javob:  $\frac{1}{2} \sqrt{2 + \sqrt{3}}$ .

9-misol.  $\operatorname{tg}(x + y) = 3$ ,  $\operatorname{tg}(x - y) = 2$  bo'lsa,  $\operatorname{tg} 2x$  ning qiymatini toping.

Yechilishi.  $\alpha = x + y$ ,  $\beta = x - y$  belgilashlar kiritamiz. Bu tengliklarni hadma-had qo'shib,  $\alpha + \beta = 2x$  tenglikni hosil qilamiz. Bundan

$$\operatorname{tg}(\alpha + \beta) = \operatorname{tg} 2x \Leftrightarrow \frac{\operatorname{tg} \alpha + \operatorname{tg} \beta}{1 - \operatorname{tg} \alpha \operatorname{tg} \beta} = \operatorname{tg} 2x \Rightarrow \frac{\operatorname{tg}(x+y) + \operatorname{tg}(x-y)}{1 - \operatorname{tg}(x+y) \operatorname{tg}(x-y)} = \operatorname{tg} 2x \Rightarrow$$

$$\Rightarrow \operatorname{tg} 2x = \frac{3 + 2}{1 - 3 \cdot 2} = \frac{5}{-5} = -1$$

Javob:  $-1$ .

10-misol.  $\frac{\sin(80^\circ + \alpha)}{4 \sin\left(20^\circ + \frac{\alpha}{4}\right) \sin\left(70^\circ - \frac{\alpha}{4}\right)}$  ifodani soddalashtiring.

$$\begin{aligned} \text{Yechilishi. } & \frac{\sin(80^\circ + \alpha)}{4 \sin\left(20^\circ + \frac{\alpha}{4}\right) \sin\left(70^\circ - \frac{\alpha}{4}\right)} = \frac{\sin 2\left(40^\circ + \frac{\alpha}{2}\right)}{4 \sin\left(20^\circ + \frac{\alpha}{4}\right) \sin\left(90^\circ - \left(20^\circ + \frac{\alpha}{4}\right)\right)} = \\ & = \frac{2 \sin\left(40^\circ + \frac{\alpha}{2}\right) \cos\left(40^\circ + \frac{\alpha}{2}\right)}{4 \sin\left(20^\circ + \frac{\alpha}{4}\right) \cos\left(20^\circ + \frac{\alpha}{4}\right)} = \frac{2 \sin\left(40^\circ + \frac{\alpha}{2}\right) \cos\left(40^\circ + \frac{\alpha}{2}\right)}{2 \sin\left(40^\circ + \frac{\alpha}{2}\right)} = \cos\left(40^\circ + \frac{\alpha}{2}\right). \end{aligned}$$

Javob:  $\cos\left(40^\circ + \frac{\alpha}{2}\right)$ .

### 6.3. Bir ismli trigonometrik funksiyalar yig'indisi va ayirmasi uchun formulalar.

1.  $\sin \alpha + \sin \beta$  yig'indini ko'paytmaga keltirish formulasini keltirib chiqarish uchun  $\alpha = x + y$ ,  $\beta = x - y$  belgilashlar kiritamiz. U holda

$$\begin{aligned} \sin \alpha + \sin \beta &= \sin(x + y) + \sin(x - y) = \\ &= \sin x \cos y + \cos x \sin y + \sin x \cos y - \cos x \sin y = 2 \sin x \cos y. \end{aligned}$$

Endi  $\begin{cases} \alpha = x + y, \\ \beta = x - y \end{cases}$  tenglamalar sistemasini yechib,

$$x = \frac{\alpha + \beta}{2}, \quad y = \frac{\alpha - \beta}{2} \text{ tengliklarga ega bo'lamiz.}$$

Shunday qilib,

$$\sin \alpha + \sin \beta = 2 \sin \frac{\alpha + \beta}{2} \cos \frac{\alpha - \beta}{2}. \quad (17)$$

2. Shunga o'xshash,

$$\sin \alpha - \sin \beta = 2 \sin \frac{\alpha - \beta}{2} \cos \frac{\alpha + \beta}{2}. \quad (18)$$

$$\cos \alpha + \cos \beta = 2 \cos \frac{\alpha + \beta}{2} \cos \frac{\alpha - \beta}{2}, \quad (19)$$

$$\cos \alpha - \cos \beta = -2 \sin \frac{\alpha + \beta}{2} \sin \frac{\alpha - \beta}{2} \quad (20)$$

formularining ham o'rinli ekanligini ko'rsatish mumkin.

### 3. Tangenslar yig'indisi uchun

$$\operatorname{tg} \alpha + \operatorname{tg} \beta = \frac{\sin \alpha}{\cos \alpha} + \frac{\sin \beta}{\cos \beta} = \frac{\sin \alpha \cos \beta + \cos \alpha \sin \beta}{\cos \alpha \sin \beta}$$

yoki

$$\operatorname{tg}\alpha + \operatorname{tg}\beta = \frac{\sin(\alpha+\beta)}{\cos\alpha\cos\beta} \quad (\alpha \neq \frac{\pi}{2} + k\pi, \beta \neq \frac{\pi}{2} + n\pi, k \in Z, n \in Z) \quad (21)$$

formulaga ega bo'lamiz.

Quyidagi formulalar ham xuddi shu kabi hosil qilinadi:

$$\operatorname{tg}\alpha - \operatorname{tg}\beta = \frac{\sin(\alpha-\beta)}{\cos\alpha\cos\beta} \quad (\alpha \neq \frac{\pi}{2} + k\pi, \beta \neq \frac{\pi}{2} + n\pi, k \in Z, n \in Z), \quad (22)$$

$$\operatorname{ctg}\alpha + \operatorname{ctg}\beta = \frac{\sin(\alpha+\beta)}{\sin\alpha\sin\beta} \quad (\alpha \neq k\pi, \beta \neq n\pi, k \in Z, n \in Z), \quad (23)$$

$$\operatorname{ctg}\alpha - \operatorname{ctg}\beta = \frac{\sin(\beta-\alpha)}{\sin\alpha\sin\beta} \quad (\alpha \neq k\pi, \beta \neq n\pi, k \in Z, n \in Z). \quad (24)$$

4.  $A\sin\alpha + B\cos\alpha$  ifodani (bu yerda  $A$  va  $B$  – ixtiyoriy haqiqiy sonlar) ko'paytmaga keltirish formulasini bilish foydalidir. Bu formula

$$A\sin\alpha + B\cos\alpha = \sqrt{A^2 + B^2} \sin(\alpha + \varphi) \quad (25)$$

ko'rinishga ega, bunda  $\cos\varphi = \pm \frac{A}{\sqrt{A^2+B^2}}$ ,  $\sin\varphi = \frac{B}{\sqrt{A^2+B^2}}$ .

(25) formuladan  $A\sin\alpha + B\cos\alpha$  ko'rinishidagi ifodalarning qiymatlar to'plamini, eng katta va eng kichik qiymatlarini topishda foydalanish mumkin.

11-misol.  $\sin\frac{7\pi}{12} - \sin\frac{\pi}{12}$  ayirmani ko'paytma shakliga keltiring.

Yechilishi. (18) formuladan foydalanamiz:

$$\sin\frac{7\pi}{12} - \sin\frac{\pi}{12} = 2\sin\frac{\frac{7\pi}{12} - \frac{\pi}{12}}{2} \cos\frac{\frac{7\pi}{12} + \frac{\pi}{12}}{2} = 2\sin\frac{\pi}{4} \cdot \cos\frac{\pi}{3} = 2 \cdot \frac{\sqrt{2}}{2} \cdot \frac{1}{2} = \frac{\sqrt{2}}{2}.$$

Javob:  $\frac{\sqrt{2}}{2}$ .

12-misol.  $\cos^2 2\alpha + \cos^2\left(\frac{2\pi}{3} + 2\alpha\right) + \cos^2\left(\frac{2\pi}{3} - 2\alpha\right)$  ifodani soddalashtiring.

Yechilishi. Berilgan ifodani soddalashtirishda darajani pasaytirish formulasi (11) va kosinuslar yig'indisini ko'paytmaga keltirish formulasi (19) dan foydalanamiz:

$$\begin{aligned} \cos^2 2\alpha + \cos^2\left(\frac{2\pi}{3} + 2\alpha\right) + \cos^2\left(\frac{2\pi}{3} - 2\alpha\right) &= \frac{1+\cos 4\alpha}{2} + \frac{1+\cos\left(\frac{4\pi}{3}+4\alpha\right)}{2} + \\ + \frac{1+\cos\left(\frac{4\pi}{3}-4\alpha\right)}{2} &= \frac{1}{2} + \frac{1}{2}\cos 4\alpha + \frac{1}{2} + \frac{1}{2}\cos\left(\frac{4\pi}{3}+4\alpha\right) + \frac{1}{2} + \frac{1}{2}\cos\left(\frac{4\pi}{3}-4\alpha\right) = \end{aligned}$$

$$\begin{aligned}
&= \frac{3}{2} + \frac{1}{2} \cos 4\alpha + \frac{1}{2} \cdot 2 \cos \frac{\frac{4\pi}{3} + 4\alpha + \frac{4\pi}{3} - 4\alpha}{2} \cos \frac{\frac{4\pi}{3} + 4\alpha - \frac{4\pi}{3} + 4\alpha}{2} = \frac{3}{2} + \frac{1}{2} \cos 4\alpha + \\
&+ \cos \frac{4\pi}{3} \cos 4\alpha = \frac{3}{2} + \frac{1}{2} \cos 4\alpha + \cos \left( \pi + \frac{\pi}{3} \right) \cos 4\alpha = \frac{3}{2} + \frac{1}{2} \cos 4\alpha - \\
&- \cos \frac{\pi}{3} \cos 4\alpha = \frac{3}{2} + \frac{1}{2} \cos 4\alpha - \frac{1}{2} \cos 4\alpha = \frac{3}{2} = 1,5.
\end{aligned}$$

Javob: 1,5.

13-misol.  $\cos 47^\circ + \sin 77^\circ - \sqrt{3} \cos 17^\circ$  ifodaning son qiymatini hisoblang.

$$\begin{aligned}
&\text{Yechilishi. } \cos 47^\circ + \sin 77^\circ - \sqrt{3} \cos 17^\circ = \cos 47^\circ + \sin \left( \frac{\pi}{2} - 13^\circ \right) - \\
&- \sqrt{3} \cos 17^\circ = \cos 47^\circ + \cos 13^\circ - \sqrt{3} \cos 17^\circ = 2 \cos \frac{47^\circ + 13^\circ}{2} \cos \frac{47^\circ - 13^\circ}{2} - \\
&- \sqrt{3} \cos 17^\circ = 2 \cos 30^\circ \cos 17^\circ - \sqrt{3} \cos 17^\circ = 2 \cdot \frac{\sqrt{3}}{2} \cos 17^\circ - \sqrt{3} \cos 17^\circ = \\
&= \sqrt{3} \cos 17^\circ - \sqrt{3} \cos 17^\circ = 0.
\end{aligned}$$

Javob: 0.

14-misol.  $3 \sin x + 4 \cos x$  ifodaning eng katta qiymatini toping

Yechilishi. (25) formuladan foydalanamiz:

$$3 \sin x + 4 \cos x = \sqrt{3^2 + 4^2} \sin(x + \varphi).$$

Bunda  $\cos \varphi = \frac{3}{5}$ ,  $\sin \varphi = \frac{4}{5}$ . Eng katta qiymat so'ralayotganligi uchun «+» ishorasi olindi. Sinusning eng katta qiymati 1 ga teng. Shu sababli berilgan ifodaning eng katta qiymati 5 ga teng.

Javob: 5.

#### 6.4. Ko'paytmani yig'indiga keltirish formulalari.

1. Sinus va kosinus ko'paytmasini yig'indiga keltirishda sinus uchun qo'shish formulalari (3) va (4)dan foydalaniladi:

$$\sin(\alpha + \beta) = \sin\alpha \cos\beta + \cos\alpha \sin\beta,$$

$$\sin(\alpha - \beta) = \sin\alpha \cos\beta - \cos\alpha \sin\beta.$$

Bu tengliklarni hadma-had qo'shib,

$$\sin \alpha \cos \beta = \frac{1}{2} (\sin(\alpha + \beta) + \sin(\alpha - \beta)) \quad (26)$$

ni hosil qilamiz

2. Kosinuslar ko'paytmasini yig'indiga keltirishda kosinus uchun qo'shish formulalari (1) va (2)dan foydalanamiz:

$$\cos(\alpha + \beta) = \sin\alpha\cos\beta - \cos\alpha\sin\beta,$$

$$\cos(\alpha - \beta) = \sin\alpha\cos\beta + \cos\alpha\sin\beta.$$

Bu tengliklarni hadma-had qo'shib,

$$\cos\alpha\cos\beta = \frac{1}{2}(\cos(\alpha + \beta) + \cos(\alpha - \beta)) \quad (27)$$

formulani hosil qilamiz.

3. Sinuslar ko'paytmasini yig'indiga keltirish uchun (2) dan (1) ni ayiramiz. U holda

$$\sin\alpha\sin\beta = \frac{1}{2}(\cos(\alpha - \beta) - \cos(\alpha + \beta)). \quad (28)$$

4. Tangenslar va kotangenslar ko'paytmalari ushbu

$$\operatorname{tg}\alpha\operatorname{tg}\beta = \frac{\operatorname{tg}\alpha + \operatorname{tg}\beta}{\operatorname{ctg}\alpha + \operatorname{ctg}\beta}, \quad (29)$$

$$\operatorname{ctg}\alpha\operatorname{ctg}\beta = \frac{\operatorname{ctg}\alpha + \operatorname{ctg}\beta}{\operatorname{tg}\alpha + \operatorname{tg}\beta}. \quad (30)$$

formular orqali yig'indiga keltiriladi.

15-misol.  $\sin 37^\circ 30' \cdot \sin 7^\circ 30'$  ni hisoblang.

Yechilishi. (28) formuladan foydalanib, ko'paytmani yig'indiga keltiramiz:

$$\begin{aligned} \sin 37^\circ 30' \cdot \sin 7^\circ 30' &= \frac{1}{2}(\cos(37^\circ 30' - 7^\circ 30') - \cos(37^\circ 30' + 7^\circ 30')) = \\ &= \frac{1}{2}(\cos 30^\circ - \cos 45^\circ) = \frac{1}{2}\left(\frac{\sqrt{3}}{2} - \frac{\sqrt{2}}{2}\right) = \frac{\sqrt{3} - \sqrt{2}}{4}. \end{aligned}$$

Javob:  $\frac{\sqrt{3} - \sqrt{2}}{4}$ .

16-misol.  $\cos^2 x \cos 3x$  ko'paytmani yig'indi shakliga keltiring.

Yechilishi.  $\cos^2 x$  uchun darajani pasaytirish formulasi (11)dan foydalanib, berilgan ifodani

$$\frac{1}{2}(1 + \cos 2x)\cos 3x = \frac{1}{2}\cos 3x + \frac{1}{2}\cos 2x\cos 3x$$

ko'rinishga keltiramiz. Hosil bo'lgan ifodadagi ko'paytmani (27) formula bo'yicha yig'indiga almashtiramiz:

$$\frac{1}{2}\cos 2x\cos 3x = \frac{1}{2} \cdot \frac{1}{2}(\cos(2x + 3x) + \cos(2x - 3x)) = \frac{1}{4}(\cos 5x + \cos x).$$

Shunday qilib,

$$\cos^2 x \cos 3x = \frac{1}{2}\cos 3x + \frac{1}{4}\cos 5x + \frac{1}{4}\cos x.$$

Javob:  $\frac{1}{2}\cos 3x + \frac{1}{4}\cos 5x + \frac{1}{4}\cos x$ .



17-misol.  $\cos 5^\circ \cos 55^\circ \cos 65^\circ$  ni hisoblang.

$$\begin{aligned} \text{Yechilishi: } \cos 5^\circ \cos 55^\circ \cos 65^\circ &= \frac{1}{2} \cos 5^\circ (\cos 120^\circ + \cos 10^\circ) = \\ &= -\frac{1}{4} \cos 5^\circ + \frac{1}{2} \cos 5^\circ \cos 10^\circ = -\frac{1}{4} \cos 5^\circ + \frac{1}{4} (\cos 15^\circ + \cos 5^\circ) = \frac{1}{4} \cos \frac{30^\circ}{2} = \\ &= \frac{1}{4} \sqrt{\frac{1+\cos 30^\circ}{2}} = \frac{1}{4} \sqrt{\frac{1+\frac{\sqrt{3}}{2}}{2}} = \frac{\sqrt{2+\sqrt{3}}}{8}. \end{aligned}$$

Javob:  $\frac{1}{8} \sqrt{2+\sqrt{3}}$ .

### 6.5. Ba'zi muhim munosabatlar.

$$\sin \alpha = \frac{2 \operatorname{tg} \frac{\alpha}{2}}{1 + \operatorname{tg}^2 \frac{\alpha}{2}}; \quad \cos \alpha = \frac{1 - \operatorname{tg}^2 \frac{\alpha}{2}}{1 + \operatorname{tg}^2 \frac{\alpha}{2}}; \quad \operatorname{tg} \alpha = \frac{2 \operatorname{tg} \frac{\alpha}{2}}{1 - \operatorname{tg}^2 \frac{\alpha}{2}}.$$

Bu yerda birinchi va ikkinchi tengliklar  $\alpha$  ning  $\pi + 2k\pi$  ( $k \in \mathbb{Z}$ ) dan boshqa, uchinchi tenglik esa  $\frac{\pi}{2} + 2k\pi$  va  $\pi + 2k\pi$  ( $k \in \mathbb{Z}$ ) lardan boshqa barcha qiymatlarida aniqlangan.

$$\sin \alpha + \sin 2\alpha + \sin 3\alpha + \dots + \sin n\alpha = \frac{\cos \frac{\alpha}{2} - \cos \frac{(2n+1)\alpha}{2}}{2 \sin \frac{\alpha}{2}},$$

$$\cos \alpha + \cos 2\alpha + \cos 3\alpha + \dots + \cos n\alpha = \frac{\sin \frac{(2n+1)\alpha}{2} - \sin \frac{\alpha}{2}}{2 \sin \frac{\alpha}{2}}.$$

Bu formulalarda  $\alpha \neq 2k\pi$  ( $k \in \mathbb{Z}$ ).

## 7-§. Trigonometrik funksiyalar

Bilamizki, har bir haqiqiy  $x$  son uchun birlik aylanada  $P_0(1; 0)$  nuqtani  $x$  radian burchakka burishdan hosil qilinadigan birgina nuqta mos keladi va bu burchak uchun  $\sin x$  hamda  $\cos x$  aniqlangan. Shu bilan har bir haqiqiy  $x$  songa  $\sin x$  va  $\cos x$  mos keltiriladi, ya'ni barcha haqiqiy sonlar to'plami  $R$  da

$$y = \sin x \text{ va } y = \cos x$$

funksiyalar aniqlangan.

$\operatorname{tg} x = \frac{\sin x}{\cos x}$  formula bilan aniqlanganligi sababli  $y = \operatorname{tg} x$  funksiya  $x$  ning  $\cos x \neq 0$  bo'lgan qiymatlarida aniqlangan.

$\operatorname{ctg} x = \frac{\cos x}{\sin x}$  formula bilan aniqlanganligidan  $y = \operatorname{ctg} x$  funksiya  $x$  ning  $\sin x \neq 0$  qiymatlarida aniqlangan.

$y = \sin x$ ,  $y = \cos x$ ,  $y = \operatorname{tg} x$ ,  $y = \operatorname{ctg} x$  funksiyalar *trigonometrik funksiyalar* deyiladi.

### 7.1. Trigonometrik funksiyalarning juft-toqligi.

Agar  $O(0: 0)$  nuqta atrofida  $\alpha$  burchakka burishda  $OP_0$  boshlang'ich radius  $OP_1$  radiusga o'tsa,  $-\alpha$  burchakka burishda  $OP_1$  ga  $Ox$  o'qiga nisbatan simmetrik bo'lgan  $OP_2$  radiusga o'tadi (118-rasm).  $P_1$  va  $P_2$  nuqtalarning absissalari teng, ordinatalari esa modul bo'yicha teng, biroq ishoralari qarama-qarshi. Bu quyidagini bildiradi:

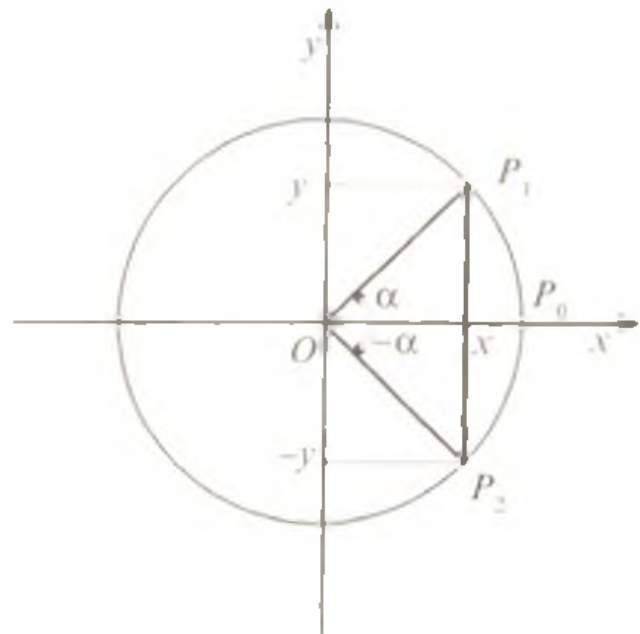

118-rasm

$$\cos(-\alpha) = \cos \alpha; \sin(-\alpha) = -\sin \alpha;$$

$$\operatorname{tg}(-\alpha) = -\operatorname{tg} \alpha; \operatorname{ctg}(-\alpha) = -\operatorname{ctg} \alpha.$$

Shunday qilib,  $y = \sin x$ ,  $y = \operatorname{tg} x$ ,  $y = \operatorname{ctg} x$  funksiyalar toq,  $y = \cos x$  funksiya esa juft funksiyadir.

1-misol.  $y = \cos\left(x - \frac{\pi}{2}\right) - x^2$  funksiyaning juft yoki toqligini aniqlang.

Yechilishi. Berilgan funksiyani keltirish formulasidan foydalanib quyidagicha yozib olamiz:

$$y = \cos\left(x - \frac{\pi}{2}\right) - x^2 = \cos\left(-\left(\frac{\pi}{2} - x\right)\right) - x^2 = \cos\left(\frac{\pi}{2} - x\right) - x^2 = \sin x - x^2.$$

Bunda  $y(-x) = \sin(-x) - (-x)^2 = -\sin x - x^2 = -(\sin x + x^2)$ .

Demak, berilgan funksiya juft ham emas, toq ham emas.

Javob: juft ham emas, toq ham emas.

2-misol.  $y = \frac{1}{2} \cos 2x \sin \left( \frac{3\pi}{2} - 2x \right) + 3$  funksiyaning juft yoki toqligini aniqlang.

Yechilishi. Bu funksiyaning ham keltirish formulasidan foydalanib juft yoki toqligini tekshirish uchun qulay shaklga keltirib olamiz:

$$y = \frac{1}{2} \cos 2x \sin \left( \frac{3\pi}{2} - 2x \right) + 3 = -\frac{1}{2} \cos 2x \cos 2x + 3 = -\frac{1}{2} \cos^2 2x + 3.$$

$$\text{Bunda } y(-x) = -\frac{1}{2} \cos^2(-2x) + 3 = -\frac{1}{2} \cos^2 2x + 3.$$

Demak, berilgan funksiya juft.

Javob: juft.

3-misol.  $y = \frac{x^3 + \sin 2x}{\cos x}$  funksiyaning juft yoki toqligini aniqlang.

$$\text{Yechilishi. } y(-x) = \frac{(-x)^3 + \sin(-2x)}{\cos(-x)} = \frac{-x^3 - \sin 2x}{\cos x} = -\frac{x^3 + \sin 2x}{\cos x}.$$

Demak,  $f(-x) = -f(x)$ , funksiyaning toqlik sharti bajarilayapti. Berilgan funksiya toq.

Javob: toq.

**7.2. Trigonometrik funksiylarning davriyligi.** Agar  $O(0; 0)$  nuqta atrofida  $x$  burchakka burishda  $OP_0$  boshlang'ich radius  $OP_1$  radiusga o'tsa,  $x \pm 2\pi$  burchakka burishda  $OP_0$  boshlang'ich radius yana  $OP_1$  radiusga o'tadi. Demak,  $\sin(x \pm 2\pi) = \sin x$ ,  $\cos(x \pm 2\pi) = \cos x$ .  $\pm 2\pi$  ga to'liq burishlar necha marta qaytarilsa ham  $P_1$  nuqtaning koordinatalari o'zgarmaydi va

$$\sin(x + 2\pi \cdot k) = \sin x, \cos(x + 2\pi \cdot k) = \cos x \quad (1)$$

tengliklar o'rinli bo'ladi. Bunda  $k$  - istalgan butun son ( $k \in \mathbb{Z}$ ).

(1) formulalar  $y = \sin x$  va  $y = \cos x$  funksiylar cheksiz ko'p davrga ega ekanligini ko'rsatadi. Funksiyaning davri haqida fikr yuritilganda uning cheksiz ko'p davrlaridan to'la aniqlangan bir davrni nazarda tutish qulay bo'lib, odatda bunday davr sifatida funksiyaning eng kichik musbat davri tushuniladi.  $y = \sin x$  va  $y = \cos x$  funksiylarning eng kichik musbat davri  $2\pi$  burchakdir. Haqiqatan ham, masalan, sinusning eng kichik musbat davrini  $T$  deb belgilasak,

$$\sin(x + T) = \sin x \quad (2)$$

bo'lib,  $x = 0$  da  $\sin T = 0$  ga ega bo'lamiz. Bu tenglamaning eng kichik ikkita musbat yechimlari  $T_1 = \pi$  va  $T_2 = 2\pi$  dan iborat. Lekin

$T_1 = \pi$  da (2) tenglik o'rinli bo'lmaydi. shu sababli  $T_2 = 2\pi$  sinusning eng kichik musbat davridir. Xuddi shunga o'xshash, kosinusning ham eng kichik musbat davri  $2\pi$  ekanligini ko'rsatish mumkin.

Shunday qilib,  $y = \sin x$  va  $y = \cos x$  funksiyalarning eng kichik musbat davri  $2\pi$  ga teng.

$y = \operatorname{tg} x$  funksiya  $\pi$  davrli funksiyadir. Haqiqatan ham, agar  $x$  bu funksiyaning aniqlanish sohasiga tegishli bo'lsa, u holda keltirish formulalaridan

$$\operatorname{tg}(x - \pi) = -\operatorname{tg}(\pi - x) = -(-\operatorname{tg} x) = \operatorname{tg} x,$$

$$\operatorname{tg}(x + \pi) = \operatorname{tg}(\pi + x) = \operatorname{tg} x.$$

Demak,  $\pi$  soni funksiyaning davri. Endi bu son  $\operatorname{tg} x$  funksiyaning eng kichik musbat davri ekanligini ko'rsatamiz:

$T$  – tangensning davri bo'lsin, u holda

$$\operatorname{tg}(x + T) = \operatorname{tg} x$$

bo'lib,  $x = 0$  da  $\operatorname{tg} T = 0$  bo'ladi. Bundan  $T = k\pi$  ( $k \in \mathbb{Z}$ ). Eng kichik musbat son 1 ga teng bo'lganligi uchun  $\pi$  soni  $y = \operatorname{tg} x$  funksiyaning eng kichik musbat davri bo'ladi.

Xuddi shunga o'xshash,  $y = \operatorname{ctg} x$  funksiyaning ham eng kichik musbat davri  $\pi$  soni ekanligini ko'rsatish mumkin.

Shunday qilib,  $y = \operatorname{tg} x$  va  $y = \operatorname{ctg} x$  funksiyalarning eng kichik musbat davri  $\pi$  ga teng.

**Teorema.** Agar  $y = f(x)$  funksiyaning eng kichik musbat davri  $T$  ga teng bo'lsa, u holda  $y = Af(kx + b)$  (bunda  $A, b, k \neq 0$  – haqiqiy

sonlar) funksiyaning eng kichik musbat davri  $\frac{T}{k}$  ga teng bo'ladi.

**Masala.**  $y = \sin ax$  funksiyaning davri  $\frac{2\pi}{a}$  ekanligini isbotlang, bunda  $a$  – biror haqiqiy son.

**Isboti.** Agar  $y = f(x)$  funksiya sonlar o'qining barcha nuqtalarida aniqlangan bo'lsa, uning  $T$  davrli davriy funksiya ekanligiga ishonch hosil qilish uchun istalgan  $x$  da  $f(x + T) = f(x)$  tenglikning to'g'riligini ko'rsatish kifoya.

Berilgan funksiya barcha  $x \in \mathbb{R}$  larda aniqlangan. Shu bilan birga

$$f\left(x + \frac{2\pi}{a}\right) = \sin a\left(x + \frac{2\pi}{a}\right) = \sin(ax + 2\pi) = \sin ax.$$

Demak,  $y = \sin ax$  funksiya  $\frac{2\pi}{a}$  davrli davriy funksiya ekan.

Shunga o'xshash,  $y = \cos bx$  funksiyaning davri  $\frac{2\pi}{b}$ ,  $y = \operatorname{tg} mx$  funksiyaning davri  $\frac{\pi}{m}$  ekanligini ko'rsatish mumkin ( $b, m$  – berilgan haqiqiy sonlar).

Agar funksiya davriy funksiyalar yig'indisidan iborat bo'lsa, bunday funksiyaning davri qo'shiluvchi funksiyalar davrining eng kichik umumiy karralisiga teng bo'ladi.

4-misol.  $y = \sin \frac{3x}{4} + 5 \cos \frac{2x}{3}$  funksiyaning eng kichik musbat davrini toping.

Yechilishi. Birinchi qo'shiluvchi funksiya  $\sin \frac{3x}{4}$  ning davri  $T_1 = \frac{2\pi}{\frac{3}{4}} = \frac{8\pi}{3}$ , ikkinchi qo'shiluvchi funksiya  $5 \cos \frac{2x}{3}$  ning davri

$$T_2 = \frac{2\pi}{\frac{2}{3}} = 3\pi.$$

Berilgan funksiyaning davri  $\frac{8\pi}{3}$  va  $3\pi$  sonlarning eng kichik umumiy karralisiga teng, ya'ni  $T = 24\pi$ .

Javob:  $24\pi$ .

### 7.3. $y = \sin x$ funksiyaning xossalari va grafigi.

1.  $y = \sin x$  funksiyaning asosiy xossalari:

a) funksiya barcha haqiqiy sonlar to'plamida aniqlangan, ya'ni  $x \in R$ ;

b) funksiya cheklangan bo'lib, uning qiymatlar to'plami  $[-1; 1]$  kesmadan iborat;  $x = \frac{\pi}{2} + 2k\pi$ ,  $k \in Z$  nuqtalarda funksiya 1 ga teng bo'lgan eng katta qiymatlarni qabul qiladi,  $x = -\frac{\pi}{2} + 2k\pi$ ,  $k \in Z$  nuqtalarda esa  $-1$  ga teng eng kichik qiymatlarni qabul qiladi;

d) funksiya toq: barcha  $x \in R$  lar uchun  $\sin(-x) = -\sin x$ ;

e) funksiya eng kichik musbat davri  $2\pi$  ga teng bo'lgan davriy funksiyadir: barcha  $x \in R$  lar uchun  $\sin(x + 2\pi) = \sin x$ ;

f) barcha  $x \in (2k\pi; \pi + 2k\pi)$ ,  $k \in Z$  larda  $\sin x > 0$ ;

g) barcha  $x \in (\pi + 2k\pi; 2\pi + 2k\pi)$ ,  $k \in Z$  larda  $\sin x < 0$ ;

h) barcha  $x = \pi k$ ,  $x \in R$  nuqtalarda  $\sin x = 0$ . Shuning uchun uning  $x$  argumentning  $0, \pm\pi; \pm 2\pi; \dots$  qiymatlari  $y = \sin x$  funksiyaning nollari deb ataladi;

i) funksiya  $\left[-\frac{\pi}{2} + 2k\pi; \frac{\pi}{2} + 2k\pi\right]$ ,  $k \in Z$  oraliqlarda  $-1$  dan  $1$  gacha o'sadi,  $\left[\frac{\pi}{2} + 2k\pi; \frac{3\pi}{2} + 2k\pi\right]$ ,  $k \in Z$  oraliqlarda esa  $1$  dan  $-1$  gacha kamayadi.

2. Sinusning xossalariidan foydalanib, avval uning grafigini uzunligi funksiyaning davriga teng bo'lgan  $[-\pi; \pi]$  oraliqda yasaymiz (119-rasm), so'ngra  $y = \sin x$  funksiyaning davriyligidan foydalanib bu grafikni

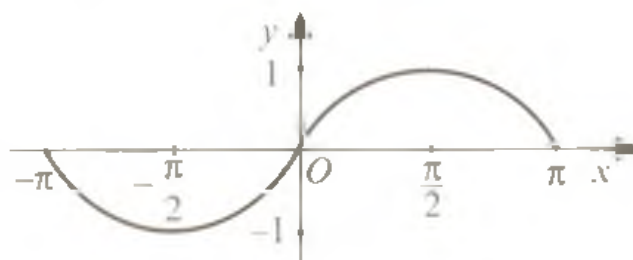

119-rasm

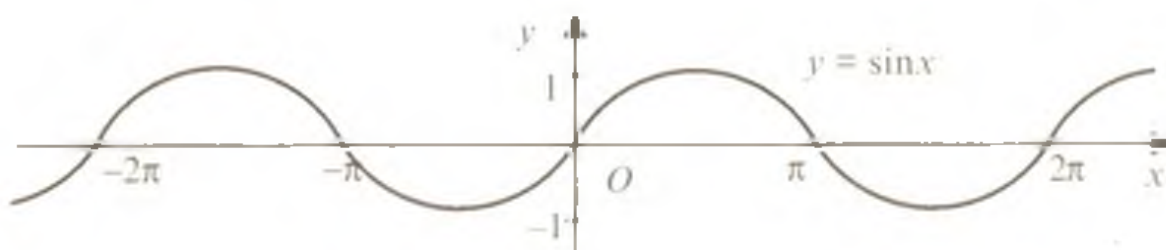

120-rasm

chapga va o'ngga davriy ravishda davom ettirib, butun sonlar o'qida funksiya grafigini yasaymiz (120-rasm). Hosil bo'lgan egri chiziq *sinusoida* deb ataladi.

#### 7.4. $y = \cos x$ funksiyaning xossalari va grafigi.

1.  $y = \cos x$  funksiyaning asosiy xossalari:

a) funksiyaning barcha haqiqiy sonlar to'plamida aniqlangan, ya'ni  $x \in R$ ;

b) funksiya cheklangan bo'lib, uning qiymatlar to'plami  $[-1; 1]$  dan iborat.  $x = 2k\pi$ ,  $x \in R$  nuqtalarda funksiya  $1$  ga teng eng katta qiymatlarni qabul qiladi,  $x = \pi + 2k\pi$ ,  $k \in Z$  nuqtalarda esa  $-1$  ga teng eng kichik qiymatlarni qabul qiladi;

d) funksiya juft: barcha  $x \in R$  lar uchun  $\cos(-x) = \cos x$ ;

e) funksiya eng kichik musbat davri  $2\pi$  ga teng bo'lgan davriy funksiya: barcha  $x \in R$  lar uchun  $\cos(x + 2\pi) = \cos x$ ;

f) barcha  $x \in \left(-\frac{\pi}{2} + 2k\pi; \frac{\pi}{2} + 2k\pi\right)$ ,  $k \in Z$  larda  $\cos x > 0$ ;

g) barcha  $x \in \left(\frac{\pi}{2} + 2k\pi; \frac{3\pi}{2} + 2k\pi\right)$ ,  $k \in Z$  larda  $\cos x < 0$ ;

h) barcha  $x = \frac{\pi}{2} + 2k\pi$ ,  $k \in Z$  nuqtalarda  $\cos x = 0$ .

Shuning uchun  $x$  argumentning  $\pm \frac{\pi}{2}$ ;  $\pm \frac{3\pi}{2}$ ;  $\pm \frac{5\pi}{2}$ ; ... qiymatlari  $y = \cos x$  funksiyaning nollari deb ataladi;

i) funksiya  $[-\pi + 2k\pi; 2k\pi]$ ,  $k \in Z$  oraliqlarda  $-1$  dan  $1$  gacha o'sadi,  $[2k\pi; \pi + 2k\pi]$ ,  $k \in Z$  oraliqlarda esa  $1$  dan  $-1$  gacha kamayadi;

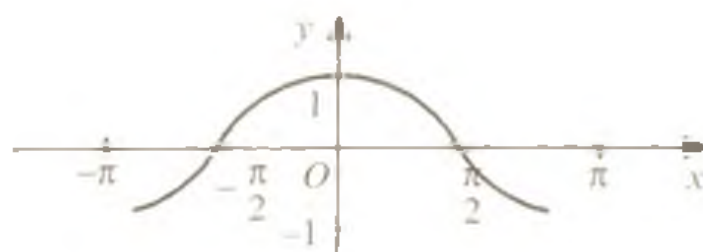

121-rasm

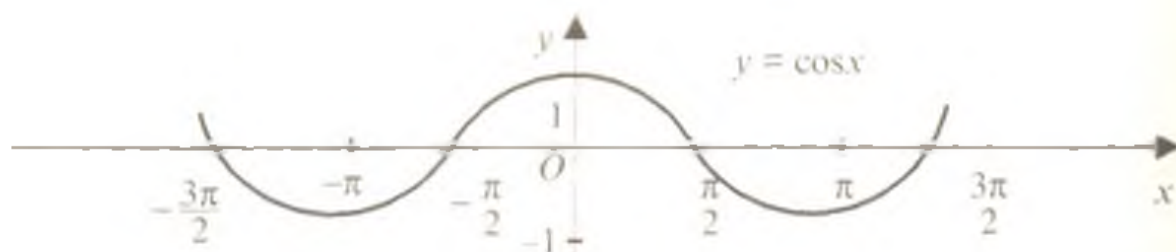

122-rasm

2. Kosinusning xossalaridan foydalanib, avval uning grafigining uzunligi funksiyaning davriga teng bo'lgan  $[-\pi; \pi]$  oraliqda yasaymiz (121-rasm), so'ngra  $y = \cos x$  funksiyaning davriyligidan foydalanib bu grafnikni chapga va o'ngga davriy ravishda davom ettirib, butun sonlar o'qida funksiya grafigini yasaymiz (122-rasm).

$\cos x = \sin\left(x + \frac{\pi}{2}\right)$  tenglik o'rinli bo'lganligi sababli bu grafnikni  $y = \sin x$  funksiya grafigini absissalar o'qi bo'ylab chapga  $\frac{\pi}{2}$  qadar siljitib ham hosil qilish mumkin. 122-rasmda tasvirlangan egri chiziq kosinusoida deb ataladi.

### 7.5. $y = \operatorname{tg} x$ funksiyaning xossalari va grafigi.

1.  $y = \operatorname{tg} x$  funksiyaning asosiy xossalari:

a) funksiya  $x$  ning  $x = \frac{\pi}{2} + k\pi, k \in Z$  dan boshqa barcha qiymatlarida aniqlangan;

b)  $y = \operatorname{tg} x$  funksiya cheklanmagan. Uning qiymatlar to'plami barcha haqiqiy sonlar to'plamidan iborat.

d) funksiya toq: funksiyaning aniqlanish sohasiga tegishli barcha  $x$  lar uchun  $\operatorname{tg}(-x) = -\operatorname{tg} x$ ;

e) funksiya eng kichik musbat davri  $\pi$  ga teng bo'lgan davriy funksiyadir: funksiyaning aniqlanish sohasiga tegishli barcha  $x$  lar uchun  $\operatorname{tg}(x + \pi) = \operatorname{tg} x$ ;

f) barcha  $x \in (k\pi; \frac{\pi}{2} + k\pi), k \in Z$  larda  $\operatorname{tg} x > 0$ ;

g) barcha  $x \in (-\frac{\pi}{2} + k\pi; k\pi), k \in Z$  larda  $\operatorname{tg} x < 0$ ;

h) barcha  $x = k\pi, k \in Z$  nuqtalarda  $\operatorname{tg} x = 0$ . Shu sababli  $x$  argumentning  $0, \pm\pi; \pm 2\pi; \pm 3\pi; \dots$  qiymatlari  $y = \operatorname{tg} x$  funksiyaning nollari deyiladi;

i) funksiya  $(-\frac{\pi}{2} + k\pi; \frac{\pi}{2} + k\pi), k \in Z$  oraliqlarda, ya'ni o'zining aniqlanish sohasida o'sadi.

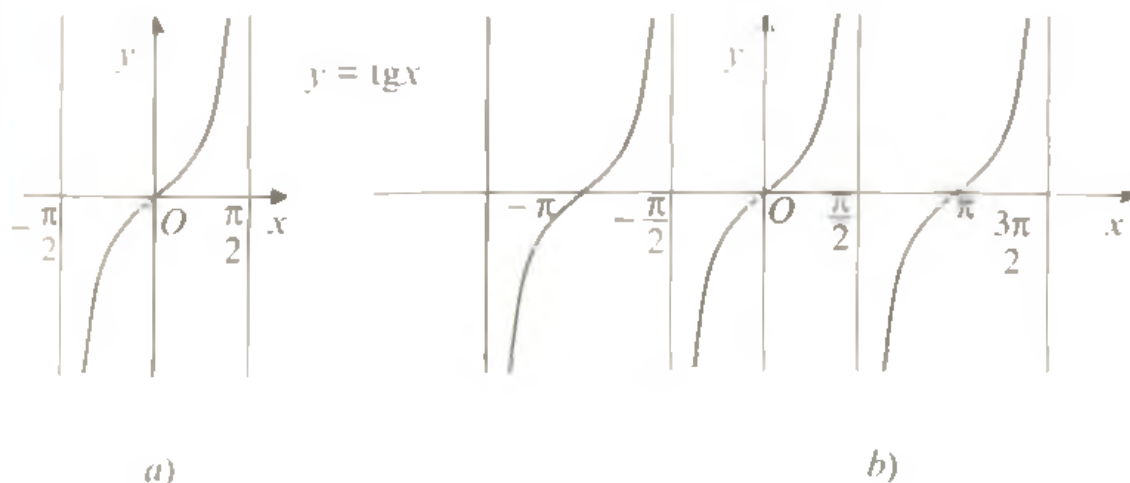

123-rasm

2. Tangensning xossalaridan foydalanib, dastlab uning grafigini uzunligi funksiyaning davriga teng bo'lgan  $(-\frac{\pi}{2}; \frac{\pi}{2})$  oraliqda yasaymiz (123-a rasm), so'ngra  $y = \operatorname{tg} x$  funksiyani davriyligidan



foydalanib bu grafikni chapga va o'ngga davriy ravishda davom ettirib, butun sonlar o'qida funksiya grafigini yasaymiz (123-b rasm).

Bu egri chiziq *tangensoida* deb ataladi.

### 7.6. $y = \text{ctgx}$ funksiyaning xossalari va grafigi.

1.  $y = \text{ctgx}$  funksiyaning asosiy xossalari:

a) funksiya  $x$  ning  $x = k\pi$ ,  $k \in Z$  dan boshqa barcha qiymatlarida aniqlangan:

b)  $y = \text{ctgx}$  funksiya cheklanmagan. Uning qiymatlar to'plami barcha haqiqiy sonlar to'plamidan iborat:

d) funksiya toq: funksiyaning aniqlanish sohasiga tegishli barcha  $x$  lar uchun  $\text{ctg}(-x) = \text{ctgx}$ :

e) funksiya eng kichik musbat davri  $\pi$  ga teng bo'lgan davriy funksiya: funksiyaning aniqlanish sohasiga tegishli barcha  $x$  lar uchun  $\text{ctg}(x + \pi) = \text{ctgx}$ :

f) barcha  $x \in \left(k\pi; \frac{\pi}{2} + k\pi\right)$ ,  $k \in Z$  larda  $\text{ctgx} > 0$ ;

g) barcha  $x \in \left(-\frac{\pi}{2} + k\pi; k\pi\right)$ ,  $k \in Z$  larda  $\text{ctgx} < 0$ ;

h) barcha  $x = \frac{\pi}{2} + k\pi$ ,  $k \in Z$  nuqtalarda  $\text{ctgx} = 0$ . Shu sababli  $x$  argumentning  $\pm \frac{\pi}{2}; \pm \frac{3\pi}{2}; \pm \frac{5\pi}{2}; \dots$  qiymatlari  $y = \text{ctgx}$  funksiyaning nollari deb ataladi;

i) funksiya  $(k\pi; \pi + k\pi)$ ,  $k \in Z$  oraliklarda, ya'ni o'zining aniqlanish sohasida kamayadi.

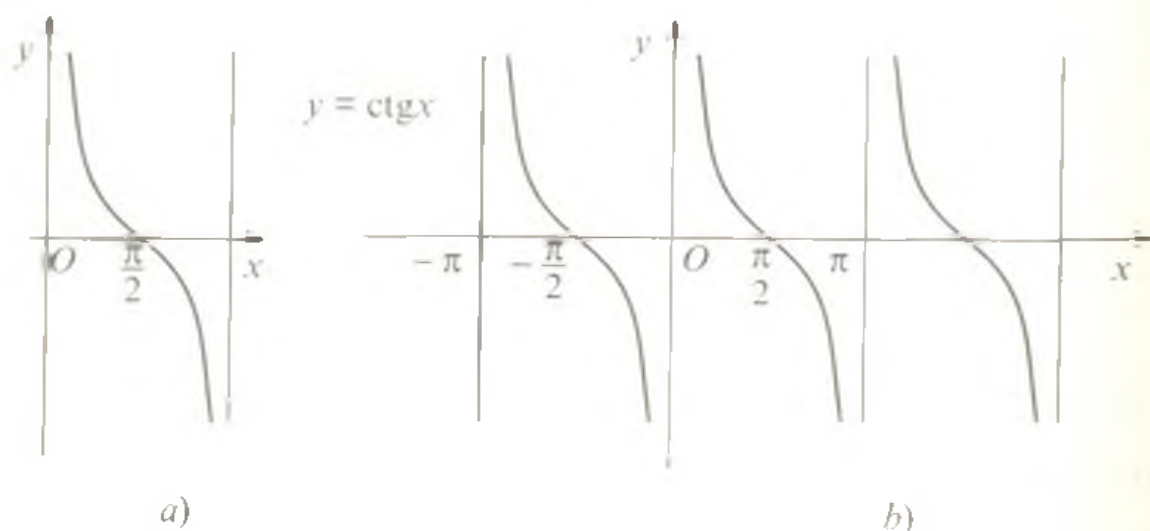

124-rasm

2. Kotangensning xossalariidan foydalanib, avval uning grafi-gini uzunligi funksiyaning davriga teng bo'lgan  $(0; \pi)$  oraliqda yasaymiz (124-a rasm). Keyin  $y = \operatorname{ctg} x$  funksiyaning davriyligi-dan foydalanib, bu grafikni chapga va o'ngga davriy ravishda davom ettirib, butun sonlar o'qida funksiya grafigini yasaymiz (124-b rasm).

$\operatorname{ctg} x = -\operatorname{tg}\left(x + \frac{\pi}{2}\right)$  tenglik o'rinli bo'lganligi sababli bu grafikni  $y = \operatorname{tg} x$  tangensoidani absissalar o'qi bo'yicha chapga  $\frac{\pi}{2}$  qadar siljitib, hosil bo'lgan egri chiziqni absissalar o'qiga nisbatan simmetrik akslantirib yasash mumkin. Bu egri chiziq *kotangensoida* deyiladi.

Trigonometrik funksiylarning aniqlanish sohasi va qiymatlar to'plamini aniqlashga doir bir necha misollar keltiramiz:

1-misol.  $y = \frac{1}{\cos^3 x + \cos x}$  funksiyaning aniqlanish sohasini toping.

Yechilishi. Argument  $x$  ning berilgan funksiya ifodasi ma'no-ga ega bo'lmaydigan, ya'ni maxrajni nolga aylantiradigan qiymat-larini topamiz:

$$\cos^3 x + \cos x = 0 \Leftrightarrow \cos x(\cos^2 x + 1) = 0.$$

Bu yerda qavs ichidagi  $\cos^2 x + 1$  ifoda  $x$  ning har qanday qiymatida ham noldan farqli. Birinchi ko'paytuvchi  $\cos x$  ning nollari  $x = \frac{\pi}{2} + k\pi, k \in Z$  lardan iborat. Demak, berilgan funksiyaning aniqlanish sohasi  $x$  ning  $\frac{\pi}{2} + k\pi, k \in Z$  lardan boshqa barcha qiymatlaridan iborat.

Javob:  $x \neq \frac{\pi}{2} + k\pi, k \in Z$ .

2-misol.  $y = \ln \cos x$  funksiyaning aniqlanish sohasini toping.

Yechilishi. Berilgan funksiya  $\cos x > 0$  da ma'noga ega. Kosinus IV va I choraklarda musbatligidan  $-\frac{\pi}{2} + 2k\pi < x < \frac{\pi}{2} + 2k\pi, k \in Z$ .

Javob:  $x \in \left[2k\pi - \frac{\pi}{2}; 2k\pi + \frac{\pi}{2}\right], k \in Z$ .

3-misol.  $y = \frac{1}{\operatorname{tg}(2\pi x^2)}$  funksiyaning aniqlanish sohasini toping.

Yechilishi.  $\operatorname{tg}(2\pi x^2)$  funksiya  $2\pi x^2 \neq \frac{k\pi}{2}$  larda aniqlangan va noldan farqli. Bundan,

$$2\pi x^2 \neq \frac{k\pi}{2} \Rightarrow x^2 \neq \frac{k}{4} \Rightarrow \left[ x \neq \pm \frac{\sqrt{k}}{2}, k = 0, 1, 2, \dots \right]$$

Javob:  $x \neq \pm \frac{\sqrt{k}}{2}, k = 0, 1, 2, \dots$

4-misol.  $y = 2 + 2 \cos 8x + 7 \sin^2 4x$  funksiyaning qiymatlar to'plamini toping.

Yechilishi. Dastlab funksiya ifodasini soddalashtiramiz:

$$\begin{aligned} y &= 2 + 2 \cos 8x + 7 \sin^2 4x = 2(1 + \cos 8x) + 7 \sin^2 4x = \\ &= 4 \cos^2 4x + 7 \sin^2 4x = 4(1 - \sin^2 4x) + 7 \sin^2 4x = 4 + 3 \sin^2 4x. \end{aligned}$$

Shunday qilib, masala  $4 + 3 \sin^2 4x$  trigonometrik ifodaning qabul qilishi mumkin bo'lgan qiymatlarini topish masalasiga keltirildi. Bunda  $0 \leq \sin^2 4x \leq 1$ .

Demak,  $4 \leq 4 + 3 \sin^2 4x \leq 7$

Javob: [4; 7].

## 8-§. Teskari trigonometrik funksiyalar. Arksinus, arkkosinus, arktangens va arkkotangens

**8.1. Teskari trigonometrik funksiya tushunchasi.**  $y = \arcsin x$  funksiya. Aytaylik,  $x$  burchak haqida faqat uning sinusi  $a$  ( $|a| < 1$ ) songa teng ekanligi ma'lum bo'lib, shu burchakni topish masalasi qo'yilgan bo'lsin. Bilamizki, sinusning davriyligi sababli  $\alpha, 180^\circ - \alpha, 360^\circ + \alpha, 540^\circ - \alpha, \dots, -180^\circ - \alpha, 360^\circ + \alpha, -540^\circ - \alpha, \dots$  burchaklar bir xil sinusga ega. Demak, burchak sinusining qiymati bo'yicha bir qiymatli aniqlanmaydi. Bunday ko'p qiymatlilikdan qutilish uchun izlanayotgan  $x$  burchak ma'lum chegarada bo'lishini talab qilish kerak bo'ladi. Ushbu teorema bunday talabga aniqlik kiritadi.

**Teorema.** Agar  $y = f(x)$  funksiya biror  $I$  oraliqda o'ssa (kamaysa) va  $a$  son shu funksiyaning bu oraliqdagi biror qiymati bo'lsa, u holda  $f(x) = a$  tenglama  $I$  oraliqda yagona yechimga ega bo'ladi.

Sinus funksiya  $\left[-\frac{\pi}{2}; \frac{\pi}{2}\right]$  kesmada o'sadi va  $-1$  dan  $1$  gacha bo'lgan qiymatlarni qabul qiladi. Shunday qilib, keltirilgan teoremaga ko'ra

$-1 \leq a \leq 1$  kesmaga tegishli har qanday  $a$  son uchun  $\sin x = a$  ( $|a| < 1$ ) tenglama

$\left[-\frac{\pi}{2}; \frac{\pi}{2}\right]$  oraliqda yagona  $b$  ildizga ega. Bu  $b$  son  $a$  sonining *arcsinusi* deb ataladi va  $\arcsin a$  kabi belgilanadi (125-rasm).

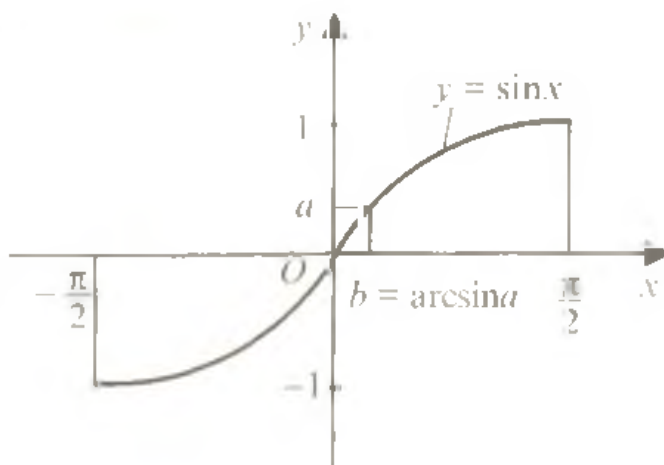

125-rasm

Shunday qilib,  $\arcsin a$

$\left[-\frac{\pi}{2}; \frac{\pi}{2}\right]$  oraliqda olingan

son bo'lib, uning sinusi  $a$  ga teng.

Yuqoridagi mulohazalar

$$x = \sin y \quad (|x| \leq 1)$$

munosabat  $y$  ning qiymati bo'yicha  $x$  ni va aksincha,  $x$  ning qiymati bo'yicha  $y$  ni topishga imkon beradi deyishga asos bo'ladi.

Demak, faqat sinusningina burchakning funksiyasi deb emas, balki burchakni ham sinusning funksiyasi deb qarash mumkin, ya'ni

$$y = \arcsin x. \quad (1)$$

bu yerda  $y$  – sinusi  $x$  ga ( $|x| \leq 1$ ) teng bo'lgan  $\left[-\frac{\pi}{2}; \frac{\pi}{2}\right]$  oraliqqa tegishli burchakdir. Bu funksiya *sinusga teskari trigonometrik funksiya* deb ataladi.  $\arcsin x$  funksiyaning grafiği  $\sin x$  funksiya grafiğiga  $y = x$  chiziqqa nisbatan simmetrikdir (126-rasm).

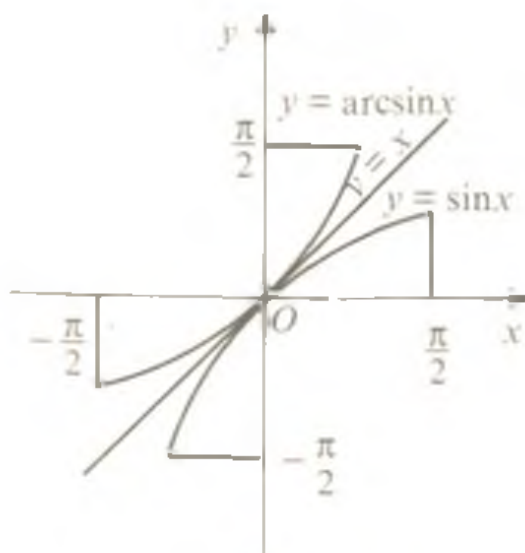

126-rasm

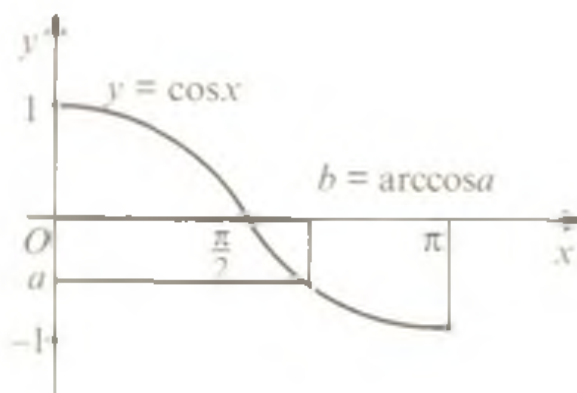

127-rasm

### 8.2. $y = \arcsin x$ funksiyaning asosiy xossalari:

a) funksiya  $[-1; 1]$  kesmada aniqlangan:  $D(y) = [-1; 1]$ ;

b) funksiya cheklangan bo'lib, uning qiymatlar to'plami

$$E(y) = \left[-\frac{\pi}{2}; \frac{\pi}{2}\right];$$

d) funksiya toq, barcha  $x \in [-1; 1]$  lar uchun  $\arcsin(-x) = -\arcsin x$ ;

e) funksiya  $x$  ning qabul qilishi mumkin bo'lgan qiymatlarida o'sadi.

**8.3.  $y = \arccos x$  funksiya.** Kosinus funksiya  $[0; \pi]$  kesmada kamayadi va  $-1$  dan  $1$  gacha bo'lgan qiymatlarni qabul qiladi. Shu sababli  $-1 \leq a \leq 1$  kesmaga tegishli har qanday  $a$  son uchun  $\cos x = a$  tenglama  $[0; \pi]$  oraliqda yagona  $b$  ildizga ega bu  $b$  son  $a$  sonning *arksinusi* deb ataladi va  $\arccos a$  kabi belgilanadi. (127-rasm).  $\arccos a$   $[0; \pi]$  oraliqda olingan son bo'lib, uning kosinusi  $a$  ga teng.

Shunday qilib, faqat kosinusning burchakning funksiyasi deb emas, balki burchakni ham kosinusning funksiyasi deb qarash mumkin, ya'ni

$$y = \arccos x. \quad (2)$$

Bu yerda  $y$  – kosinusi  $x$  ga ( $|x| \leq 1$ ) teng bo'lgan  $[0; \pi]$  oraliqqa tegishli burchakdir. Bu funksiya kosinusga teskari trigonometrik funksiya deb ataladi. Uning grafiqi 128-rasmda tasvirlangan.

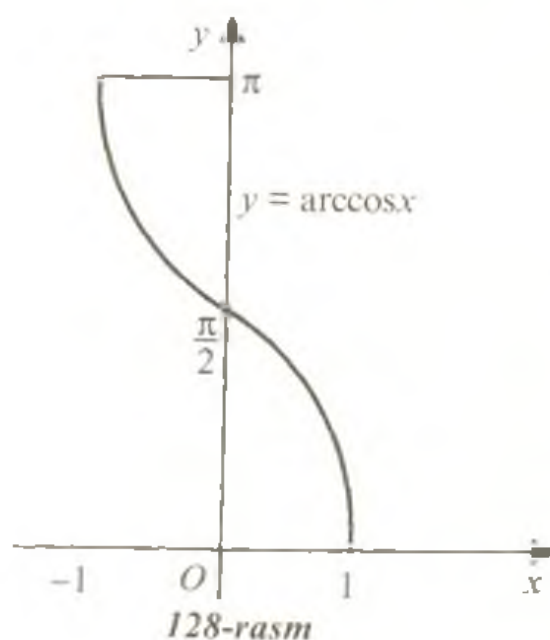

### 8.4. $y = \arccos x$ funksiyaning asosiy xossalari:

a) funksiya  $[-1; 1]$  kesmada aniqlangan:  $D(y) = [-1; 1]$ ;

b) funksiya cheklangan bo'lib, uning qiymatlar to'plami  $E(y) = [0; \pi]$ ;

d)  $y = \arccos x$  funksiya juft ham emas, toq ham emas:

$$\arccos(-x) = \pi - \arccos x;$$

e)  $x = 1$  da  $\arccos x = 0$ ;

f) funksiya  $x$  ning qabul qilishi mumkin bo'lgan qiymatlarida kamayadi.

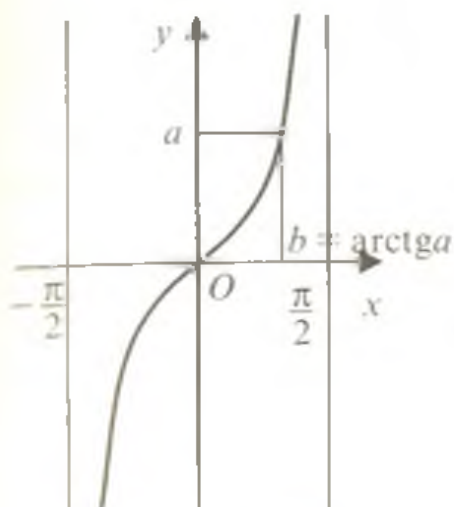

129-rasm

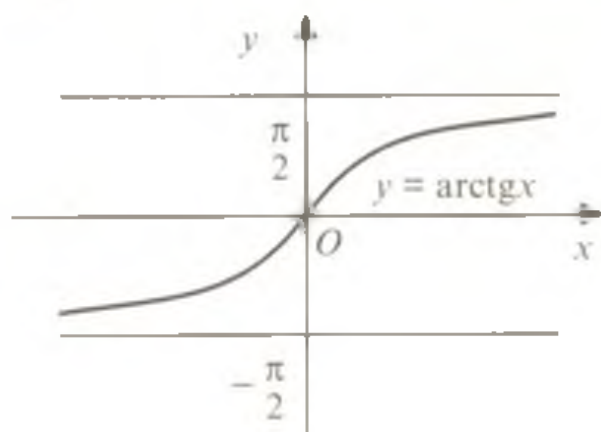

130-rasm

**8.5.  $y = \text{arctg} x$  funksiya.** Tangens funksiya  $\left(-\frac{\pi}{2}; \frac{\pi}{2}\right)$  oraliqda o'sadi va haqiqiy sonlar to'plamidagi barcha qiymatlarni qabul qiladi. Shu sababli har qanday  $a$  son uchun  $\text{tg} x = a$  tenglama  $\left(-\frac{\pi}{2}; \frac{\pi}{2}\right)$  oraliqda yagona  $b$  ildizga ega va bu  $b$  son  $a$  sonning *arctangensi* deb ataladi va  $\text{arctg} a$  kabi belgilanadi (129-rasm)

$\text{arctg} a$   $\left(-\frac{\pi}{2}; \frac{\pi}{2}\right)$  oraliqda olingan son bo'lib, uning tangensi  $a$  ga teng.

Shunday qilib, faqat tangensning burchakning funksiyasi deb emas, balki burchakni ham tangensning funksiyasi deb qarash mumkin, ya'ni

$$y = \text{arctg} x, \quad (3)$$

bu yerda  $y$  – tangenci  $x$  ga teng bo'lgan  $x \in R \left(-\frac{\pi}{2}; \frac{\pi}{2}\right)$  oraliqqa tegishli burchakdir. Bu funksiya tangensga teskari trigonometrik funksiya deb ataladi, uning grafigi 130-rasmida tasvirlangan.

**8.6.  $y = \text{arctg} x$  funksiyaning asosiy xossalari:**

a) funksiya barcha haqiqiy sonlar to'plamida aniqlangan:

$$D(y) = (-\infty; +\infty);$$

b) funksiya cheklangan bo'lib, uning qiymatlar to'plami

$$E(y) = \left(-\frac{\pi}{2}; \frac{\pi}{2}\right);$$

d)  $y = \text{arctg} x$  toq funksiya:  $\text{arctg}(-x) = -\text{arctg} x$ ;

e)  $x = 0$  da  $\text{arctg} x = 0$ ;

f) funksiya  $x$  ning qabul qilishi mumkin bo'lgan qiymatlarida o'sadi.

**8.7.  $y = \text{arccot}x$  funksiya.** Kotangens funksiya  $(0; \pi)$  oraliqda kamayadi va haqiqiy sonlar to'plamidagi barcha qiymatlarni qabul qiladi. Shu sababli har qanday  $a$  son uchun  $\text{ctgx} = a$  tenglama  $(0; \pi)$  oraliqda yagona  $b$  ildizga ega va bu  $b$  son  $a$  sonning arkkotangensi deb ataladi va  $\text{arccot}a$  kabi belgilanadi (131-rasm).  $\text{arccot}a$   $(0; \pi)$  oraliqda olingan son bo'lib, uning kotangensi  $a$  ga teng. Shunday qilib, faqat kotangensning burchakning funksiyasi deb emas, balki burchakni ham kotangensning funksiyasi deb qarash mumkin, ya'ni

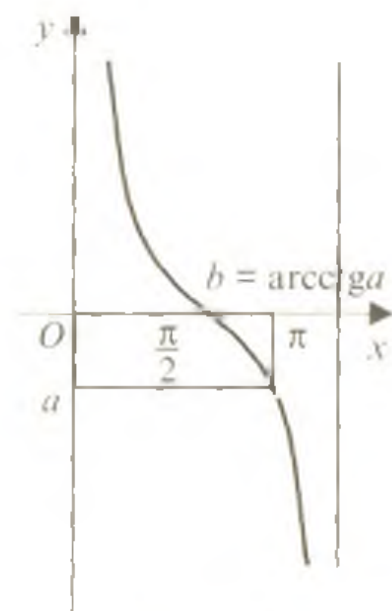

131-rasm

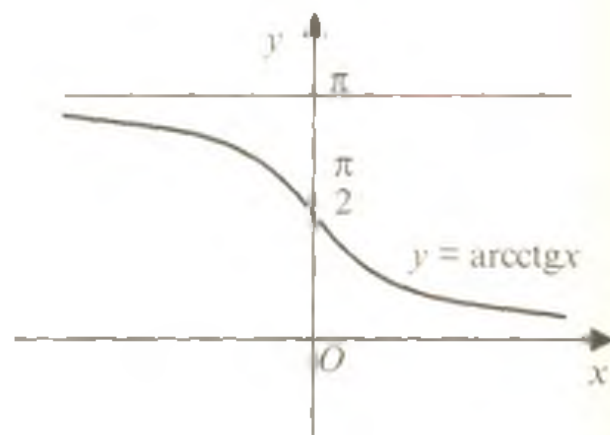

132-rasm

$$y = \text{arccot} x, \quad (4)$$

bu yerda  $y$  – kotangensi  $x$  ( $x \in R$ ) ga teng bo'lgan  $(0; \pi)$  oraliqqa tegishli burchakdir. Bu funksiya *kotangensga teskari trigonometrik funksiya* deb ataladi. Uning grafigi 132-rasmda tasvirlangan.

**8.8.  $y = \text{arccot}x$  funksiyaning asosiy xossalari:**

a) funksiya barcha haqiqiy sonlar to'plamida aniqlangan:

$$D(y) = (-\infty; +\infty);$$

b) funksiya cheklangan, uning qiymatlar to'plami  $E(y) = (0; \pi)$ ;

d)  $y = \text{arccot}x$  funksiya juft ham emas, toq ham emas:

$$\text{arccot}(-x) = \pi - \text{arccot}x;$$

e) funksiya  $x$  ning qabul qilishi mumkin bo'lgan qiymatlarida kamayadi.

### 8.9. Teskari trigonometrik funksiyalar uchun ayniyatlar:

1)  $\arcsin x + \arccos x = \frac{\pi}{2}$  ( $|x| \leq 1$ ), masalan,  $\arcsin \frac{1}{2} + \arccos \frac{1}{2} =$   
 $= \frac{\pi}{6} + \frac{\pi}{3} = \frac{\pi}{2}$ ;

2)  $(\sin(\arcsin x)) = x$  ( $|x| \leq 1$ ), masalan,  $\sin(\arcsin \frac{1}{2}) = \sin(\frac{\pi}{6}) = \frac{1}{2}$ ;

3)  $(\cos(\arccos x)) = x$  ( $|x| \leq 1$ ), masalan,

$$\cos(\arccos \frac{1}{2}) = \cos(\frac{\pi}{3}) = \frac{1}{2};$$

4)  $\arcsin(\sin x) = x$  ( $x \leq \frac{\pi}{2}$ ), masalan,

$$\arcsin(\sin \frac{\pi}{6}) = \arcsin(\frac{1}{2}) = \frac{\pi}{6};$$

5)  $\arccos(\cos x) = x$  ( $0 \leq x \leq \pi$ ), masalan,

$$\arccos(\cos \frac{2\pi}{3}) = \arccos(-\frac{1}{2}) = \frac{2\pi}{3};$$

6)  $\operatorname{arctg} x + \operatorname{arccotg} x = \frac{\pi}{2}$  ( $x \in R$ ), masalan,

$$\operatorname{arctg} \sqrt{3} + \operatorname{arccotg} \sqrt{3} = \frac{\pi}{3} + \frac{\pi}{6} = \frac{\pi}{2};$$

7)  $\operatorname{tg}(\operatorname{arctg} x) = x$  ( $x \in R$ ), masalan,  $\operatorname{tg}(\operatorname{arctg} 1) = \operatorname{tg} \frac{\pi}{4} = 1$ ;

8)  $\operatorname{arctg}(\operatorname{tg} x) = x$  ( $x < \frac{\pi}{2}$ ), masalan,  $\operatorname{arctg}(\operatorname{tg} \frac{\pi}{4}) = \operatorname{arctg} 1 = \frac{\pi}{4}$ ;

9)  $\operatorname{ctg}(\operatorname{arccotg} x) = x$  ( $x \in R$ ), masalan,  $\operatorname{ctg}(\operatorname{arccotg} \sqrt{3}) = \operatorname{ctg} \frac{\pi}{6} = \sqrt{3}$ ;

10)  $\operatorname{arccotg}(\operatorname{ctg} x) = x$  ( $0 < x < \pi$ ), masalan,

$$\operatorname{arccotg}(\operatorname{ctg} \frac{\pi}{4}) = \operatorname{arccotg} 1 = \frac{\pi}{4};$$

$$11) \arcsin x = \begin{cases} \arccos \sqrt{1-x^2}, & 0 \leq x \leq 1, \\ -\arccos \sqrt{1-x^2}, & -1 \leq x \leq 0; \end{cases}$$

$$12) \arcsin x = \operatorname{arctg} \frac{x}{\sqrt{1-x^2}}, \quad -1 < x < 1,$$

$$13) \operatorname{arctg} x = \arcsin \frac{x}{\sqrt{1+x^2}}, \quad -\infty < x < \infty.$$



1-misol.  $y = \arccos \frac{1-2x}{4}$  funksiyaning aniqlanish sohasini toping.

Yechilishi. Arkkosinus funksiya argumentning  $[-1; 1]$  oraliqlardagi qiymatlarida aniqlanganligidan,

$$-1 \leq \frac{1-2x}{4} \leq 1 \Leftrightarrow -4 \leq 1-2x \leq 4 \Leftrightarrow -3 \leq 2x \leq 5 \Leftrightarrow -1,5 \leq x \leq 2,5.$$

Javob:  $x \in [-1,5; 2,5]$ .

2-misol.  $\arcsin \frac{1}{2} - 3 \arcsin \left(-\frac{1}{2}\right) + \arccos \frac{1}{2} + 2 \arcsin 1 - 2 \arccos(-1)$  ifoda qiymatini hisoblang.

Yechilishi. Ifoda qiymatini teskari trigonometrik funksiyalar ta'riflaridan foydalanib hisoblaymiz:

$$\arcsin \frac{1}{2} - 3 \arcsin \left(-\frac{1}{2}\right) + \arccos \frac{1}{2} + 2 \arcsin 1 - 2 \arccos(-1) = \frac{\pi}{6} - 3 \cdot \left(-\frac{\pi}{6}\right) + \frac{\pi}{3} + 2 \cdot \frac{\pi}{2} - 2\pi = \frac{\pi}{6} + \frac{\pi}{2} + \frac{\pi}{3} + \pi - 2\pi = \pi - \pi = 0.$$

Javob: 0.

3-misol.  $\sin \left(\arccos \left(-\frac{1}{2}\right) - \arcsin \left(-\frac{1}{2}\right)\right) + \cos \left(-3 \arcsin \frac{1}{2}\right)$  ifodaning son qiymatini hisoblang.

Yechilishi. 1)  $\arccos \left(-\frac{1}{2}\right) = \alpha$  bo'lsin, u holda  $\cos \alpha = -\frac{1}{2}$  va  $\cos \alpha \in [0; \pi]$ . Bundan  $\alpha = \frac{2\pi}{3}$ .

2)  $\arcsin \left(-\frac{1}{2}\right) = \beta$  bo'lsin, u holda  $\sin \beta = -\frac{1}{2}$  va  $\beta \in \left[-\frac{\pi}{2}; \frac{\pi}{2}\right]$ . Bundan  $\beta = -\frac{\pi}{6}$ .

3)  $\arcsin \left(\frac{1}{2}\right) = \gamma$  bo'lsin, u holda  $\sin \gamma = \frac{1}{2}$  va  $\gamma \in \left[-\frac{\pi}{2}; \frac{\pi}{2}\right]$ . Bundan  $\gamma \in \frac{\pi}{6}$ .

Topilgan qiymatlarni berilgan ifodaga qo'yamiz:

$$\begin{aligned} \sin \left(\frac{2\pi}{3} - \left(-\frac{\pi}{6}\right)\right) + \cos \left(-3 \cdot \frac{\pi}{6}\right) &= \sin \left(\frac{2\pi}{3} + \frac{\pi}{6}\right) + \cos \left(\frac{\pi}{2}\right) = \sin \frac{5\pi}{6} + \cos \frac{\pi}{2} = \\ &= \sin \left(\frac{\pi}{2} + \frac{\pi}{3}\right) + 0 = \cos \frac{\pi}{3} = \frac{1}{2}. \end{aligned}$$

Javob:  $\frac{1}{2}$ .

4-misol.  $\cos\left(2 \arccos \frac{12}{13}\right)$  ni hisoblang.

Yechilishi.  $\arccos \frac{12}{13} = \alpha$  bo'lsin, u holda  $\cos \alpha = \frac{12}{13}$  va

$$\alpha \in [0; \pi], \sin \alpha \geq 0, \sin \alpha = \sqrt{1 - \cos^2 \alpha} = \sqrt{1 - \frac{144}{169}} = \frac{5}{9}.$$

$$\cos 2\alpha = \cos^2 \alpha - \sin^2 \alpha = \frac{144}{169} - \frac{25}{169} = \frac{119}{169}.$$

Javob:  $\frac{119}{169}$ .

5-misol.  $\operatorname{tg}\left(\arcsin\left(-\frac{12}{13}\right) + \arccos 0,8\right)$  ni hisoblang.

Yechilishi. 1)  $\arcsin\left(-\frac{12}{13}\right) = \alpha$  bo'lsin, u holda  $\sin \alpha = -\frac{12}{13}$

va  $\alpha \in \left(-\frac{\pi}{2}; 0\right)$ .

$$\operatorname{ctg}^2 \alpha = \frac{1}{\sin^2 \alpha} - 1 = \frac{169}{144} - 1 = \frac{25}{144}; \alpha \in \left(-\frac{\pi}{2}; 0\right), \operatorname{ctg} \alpha = -\frac{5}{12}, \operatorname{tg} \alpha = -\frac{12}{5};$$

2)  $\arccos(0,8) = \beta$  bo'lsin, u holda

$$\beta \in \left(0; \frac{\pi}{2}\right), \operatorname{tg}^2 \beta = \frac{1}{\cos^2 \beta} - 1 = \frac{25}{16} - 1 = \frac{9}{16}, \operatorname{tg} \beta = \frac{3}{4}.$$

$$3) \operatorname{tg}(\alpha + \beta) = \frac{\operatorname{tg} \alpha + \operatorname{tg} \beta}{1 - \operatorname{tg} \alpha \operatorname{tg} \beta} = \frac{-\frac{12}{5} + \frac{3}{4}}{1 - \frac{12}{5} \cdot \frac{3}{4}} = \frac{-\frac{48+15}{20}}{\frac{56}{20}} = -\frac{33}{56}.$$

Javob:  $-\frac{33}{56}$ .

6-misol.  $y = \frac{\arcsin 2x}{\ln(x+1)}$  funksiyaning aniqlanish sohasini toping.

$$\text{Yechilishi. } \begin{cases} -1 \leq 2x \leq 1 \\ x+1 > 0 \\ \ln(x+1) \neq 0 \end{cases} \Rightarrow \begin{cases} -\frac{1}{2} \leq x \leq \frac{1}{2} \\ x > -1 \\ x \neq 0 \end{cases} \Rightarrow x \in \left[-\frac{1}{2}; 0\right) \cup \left(0; \frac{1}{2}\right].$$

Javob:  $x \in \left[-\frac{1}{2}; 0\right) \cup \left(0; \frac{1}{2}\right]$ .

## Mustaqil ishlash uchun test topshiriqlari

1.  $80^\circ$  ning radian o'lovini toping

- A) 1,5;    B) 1,3;    C)  $\frac{4\pi}{9}$ ;    D)  $\frac{3\pi}{5}$ ;    E)  $\frac{2\pi}{5}$ .

2.  $\frac{4\pi}{5}$  radian necha gradusga teng?

- A)  $114^\circ$ ;    B)  $132^\circ$ ;    C)  $145^\circ$ ;    D)  $144^\circ$ ;    E)  $160^\circ$ .

3. Quyidagi ifodalardan qaysi biri musbat?

$$M = \frac{\cos 320^\circ}{\sin 217^\circ}; \quad N = \frac{\operatorname{ctg} 187^\circ}{\operatorname{tg} 2^\circ}; \quad P = \frac{\operatorname{tg} 195^\circ}{\sin 147^\circ}; \quad Q = \frac{\sin 3}{\cos 4}.$$

- A)  $P$ ;    B)  $Q$ ;    C)  $M$ ;    D)  $N$ ;    E) hech qaysisini.

4. Agar  $\operatorname{tg} \alpha \cdot \cos \alpha > 0$  bo'lsa,  $\alpha$  burchak qaysi chorakka tegishli?

- A) III yoki IV;    B) I yoki III;    C) I yoki IV;    D) II yoki III;  
E) I yoki II.

5. Quyidagi ko'paytmalardan qaysilari musbat?

1)  $\sin 4,1 \cdot \operatorname{tg} 3,41$ ;    2)  $\cos 2,5 \cdot \sin 5,8$     3)  $\operatorname{ctg} 5,7 \cdot \cos 1,9$ .

- A) 1;    B) 1; 2;    C) 2;    D) 1; 3;    E) 2; 3.

6.  $P(4;0)$  nuqtani koordinata boshi atrofidan  $90^\circ$  ga burganda u qaysi nuqtaga o'tadi?

- A)  $(-4;0)$ ;    B)  $(0;-4)$ ;    C)  $(4;4)$ ;    D)  $(0;4)$ ;    E)  $(4;-4)$ .

7.  $\operatorname{tg} 225^\circ \cdot \cos 330^\circ \cdot \operatorname{ctg} 120^\circ \cdot \sin 240^\circ$  ni hisoblang.

- A)  $\frac{\sqrt{3}}{4}$ ;    B)  $-\frac{\sqrt{3}}{4}$ ;    C)  $\frac{1}{4}$ ;    D)  $-\frac{1}{4}$ ;    E)  $\frac{1}{2}$ .

8.  $\operatorname{ctg} \frac{5\pi}{3} \sin \frac{3\pi}{4} \operatorname{tg} \frac{5\pi}{6} \cos \frac{4\pi}{3}$  ni hisoblang.

- A)  $\frac{\sqrt{2}}{4}$ ;    B)  $-\frac{\sqrt{2}}{4}$ ;    C)  $\frac{\sqrt{2}}{12}$ ;    D)  $-\frac{\sqrt{2}}{12}$ ;    E)  $\frac{\sqrt{2}}{2}$ .

9.  $\sin 915^\circ$  ni hisoblang.

- A)  $-\frac{1}{2} \sqrt{2-\sqrt{3}}$ ;    B)  $\frac{1}{2} \sqrt{2-\sqrt{3}}$ ;    S)  $-\frac{1}{2} \sqrt{2+\sqrt{3}}$ ;

- D)  $-\frac{1}{2} \sqrt{2-\sqrt{3}}$ ;    E)  $-\frac{\sqrt{3}}{2}$ .

10.  $\operatorname{tg} 2010^\circ$  ning qiymatini hisoblang.

- A) 1;    B)  $\frac{\sqrt{3}}{3}$ ;    C)  $-\frac{1}{\sqrt{3}}$ ;    D)  $\sqrt{3}$ ;    E)  $-\sqrt{3}$ .

11. Agar  $\operatorname{tg} \alpha = -\frac{5}{12}$ ,  $\frac{\pi}{2} < \alpha < \pi$  bo'lsa,  $\cos \alpha$  ning qiymatini toping.

A)  $\frac{5}{13}$ ; B)  $-\frac{5}{13}$ ; C)  $\frac{12}{13}$ ; D)  $\frac{144}{169}$ ; E)  $-\frac{12}{13}$ .

12. Agar  $\operatorname{tg}\alpha = -\frac{5}{12}$ ,  $\frac{\pi}{2} < \alpha < \pi$  bo'lsa,  $\sin\alpha$  ning qiymatini toping.

A)  $\frac{5}{13}$ ; B)  $-\frac{5}{13}$ ; C)  $\frac{12}{13}$ ; D)  $\frac{144}{169}$ ; E)  $-\frac{12}{13}$ .

13. Agar  $\cos\alpha = \frac{1}{2}$ ,  $0 < \alpha < \frac{\pi}{2}$  bo'lsa,  $\sin\left(\frac{\pi}{3} + \alpha\right)$  ning qiymatini toping.

A)  $\frac{\sqrt{3}}{2}$ ; B)  $\frac{1}{2}$ ; C)  $\frac{\sqrt{2}}{2}$ ; D) 1; E) 0.

14. Agar  $\sin\alpha = \frac{2}{3}$ ,  $\cos\beta = -\frac{3}{4}$ ,  $\frac{\pi}{2} < \alpha < \pi$ ,  $\frac{\pi}{2} < \beta < \pi$  bo'lsa,  $\cos(\alpha + \beta)$  ni hisoblang.

A)  $-\frac{1}{12}$ ; B)  $\frac{3\sqrt{5}-2\sqrt{7}}{12}$ ; C)  $\frac{3\sqrt{5}+2\sqrt{7}}{12}$ ; D)  $-\frac{3\sqrt{5}-2\sqrt{7}}{12}$ ;

E)  $-\frac{3\sqrt{5}+2\sqrt{7}}{12}$ .

15\*.  $\operatorname{ctg}2^\circ \cdot \operatorname{ctg}4^\circ \cdot \operatorname{ctg}6^\circ \cdot \dots \cdot \operatorname{ctg}88^\circ$  ni hisoblang.

A) 1; B) -1; C)  $\sqrt{3}$ ; D)  $-\sqrt{3}$ ; E) Hisoblab bo'lmaydi.

16.  $\sin 160^\circ \cos 110^\circ + \sin 250^\circ \cos 340^\circ + \operatorname{tg} 110^\circ \cdot \operatorname{tg} 340^\circ$  ni hisoblang.

A) 1; B) -1; C) 0; D)  $\frac{1}{2}$ ; E)  $-\frac{1}{2}$ .

17.  $\frac{\operatorname{tg}^2 52.5^\circ - \operatorname{tg}^2 7.5^\circ}{1 - \operatorname{tg}^2 7.5^\circ \operatorname{tg}^2 52.5^\circ}$  ni hisoblang.

A) 1; B) -1; C)  $\frac{1}{\sqrt{3}}$ ; D)  $\sqrt{3}$ ; E)  $-\sqrt{3}$ .

18.  $\sin \frac{\pi}{12} \cos \frac{\pi}{12} + \left(\sin^2 \frac{\pi}{8} - \cos^2 \frac{\pi}{8}\right)^2$  ni hisoblang.

A)  $\frac{1}{2}$ ; B)  $\frac{3}{4}$ ; C)  $\frac{\sqrt{2}}{2}$ ; D)  $\frac{\sqrt{3}}{2}$ ; E) 1.

19.  $\cos^2 \frac{\pi}{12} - \cos^2 \frac{5\pi}{12}$  ni hisoblang.

A)  $\frac{1}{2}$ ; B)  $-\frac{\sqrt{3}}{2}$ ; C)  $\frac{\sqrt{3}}{2}$ ; D) 1; E) -1.

20.  $\frac{\cos^2\left(\frac{3\pi}{2}+\alpha\right)}{\operatorname{tg}^2(\alpha-2\pi)} + \frac{\cos^2(\pi-\alpha)}{\operatorname{tg}^2\left(\alpha-\frac{3\pi}{2}\right)}$  ni soddalashtiring.

A) 0; B)  $\operatorname{tg}^2\alpha$ ; C) 1; D)  $\sin^2\alpha$ ; E)  $\cos^2\alpha$ .

21. Agar  $\operatorname{tg}\alpha = \frac{2}{3}$  bo'lsa,  $\frac{2\sin\alpha-3\cos\alpha}{3\cos\alpha+2\sin\alpha}$  ning qiymatini toping.

A)  $-\frac{1}{5}$ ; B)  $-\frac{1}{13}$ ; C)  $\frac{4}{3}$ ; D)  $\frac{4}{13}$ ; E)  $-\frac{5}{13}$ .

22. Agar  $\sin\alpha + \cos\alpha = \frac{4}{3}$  bo'lsa,  $\sin\alpha\cos\alpha$  ning qiymatini toping.

A)  $\frac{9}{16}$ ; B)  $\frac{8}{9}$ ; C)  $\frac{7}{16}$ ; D)  $\frac{7}{18}$ ; E) 1.

23.  $(\sin\alpha + \cos\alpha)^2 - \frac{2}{\operatorname{tg}\alpha + \operatorname{ctg}\alpha} - 1$  ni soddalashtiring.

A) 0; B) 1; C) 2; D) -3; E) -4.

24. Ifodani soddalashtiring:

$$\frac{1-2\sin^2(\pi+\alpha)}{\sin\left(\frac{\pi}{2}+\alpha\right)+\sin(\pi-\alpha)} + \frac{1-2\cos^2(\pi-\alpha)}{\cos(\pi+\alpha)+\cos\left(\frac{\pi}{2}-\alpha\right)}$$

A)  $\sin\alpha$ ; B) 0; C)  $2\cos\alpha$ ; D)  $\operatorname{tg}^2\alpha$ ; E)  $\operatorname{tg}\alpha$ .

25.  $\frac{\sin(\pi+\alpha)\cos(\pi-\alpha)-\operatorname{tg}\left(\frac{\pi}{2}-\alpha\right)}{1-\left(\sin\left(\frac{\pi}{2}+\alpha\right)+\sin(\pi-\alpha)\right)^2}$  ni soddalashtiring.

A)  $\operatorname{tg}^2\alpha$ ; B)  $2\operatorname{tg}^2\alpha$ ; C)  $\operatorname{ctg}^2\alpha$ ; D)  $\frac{1}{2}\operatorname{ctg}^2\alpha$ ; E)  $\cos\alpha$ .

26. Agar  $\operatorname{tg}\alpha = \frac{7}{24}$ ,  $\pi < \alpha < \frac{3\pi}{2}$  bo'lsa,  $\cos\frac{\alpha}{2}$  ni hisoblang.

A)  $-\frac{\sqrt{2}}{10}$ ; B)  $\frac{\sqrt{2}}{10}$ ; C)  $\frac{7\sqrt{2}}{10}$ ; D)  $-\frac{7\sqrt{2}}{10}$ ; E)  $\frac{1}{5}$ .

27.  $2 - 4\sin^2\frac{5\pi}{12}$  ni hisoblang.

A) 0; B)  $-\sqrt{3}$ ; C)  $\sqrt{3}$ ; D)  $\frac{1}{2}$ ; E)  $-\frac{1}{2}$ .

28\*.  $2\cos\frac{\pi}{8}\sin\frac{7\pi}{8}$  ni hisoblang.

A) 2;      B) 1;      C)  $\frac{\sqrt{3}}{2}$ ;      D)  $\frac{\sqrt{2}}{2}$ ;      E)  $\sqrt{2}$ .

29\*.  $\sin \frac{\pi}{10} \sin \frac{3\pi}{10}$  ni hisoblang.

A)  $\cos \frac{\pi}{10}$ ;      B)  $\frac{1}{8}$ ;      C)  $\frac{1}{4}$ ;      D)  $\frac{1}{2}$ ;      E)  $-\frac{1}{8}$ .

30.  $\cos^4 \frac{13\pi}{12} - \sin^4 \frac{13\pi}{12}$  ni soddallashtiring.

A)  $\frac{\sqrt{3}}{2}$ ;      B)  $-\frac{\sqrt{3}}{2}$ ;      C)  $\frac{1}{2}$ ;      D)  $-\frac{1}{2}$ ;      E) 1.

31.  $\operatorname{ctg} \frac{7\pi}{8} + \operatorname{tg} \frac{7\pi}{8}$  ni soddallashtiring.

A)  $\sqrt{2}$ ;      B)  $-\sqrt{2}$ ;      C)  $2\sqrt{2}$ ;      D)  $-2\sqrt{2}$ ;      E)  $\frac{\sqrt{2}}{2}$ .

32.  $\sin^4 \alpha + \cos^4 \alpha - \sin^6 \alpha - \cos^6 \alpha - \sin^2 \alpha \cos^2 \alpha$  ni soddallashtiring.

A)  $\sin^2 \alpha$ ;      B) 0;      C) 1;      D) 2;      E)  $\cos^2 \alpha$ .

33.  $\operatorname{tg} \alpha$  va  $\operatorname{ctg} \beta$   $4x^2 - 3x - 2 = 0$  tenglamaning ildizlari bo'lsa,  $\operatorname{tg}(\alpha + \beta)$  ni toping.

A)  $\frac{3}{2}$ ;      B) 1;      C) 3;      D)  $\frac{1}{2}$ ;      E) 4.

34.  $\frac{\sin 37^\circ - \sin 53^\circ}{1 - 2 \cos^2 41^\circ}$  ifodaning qiymatini hisoblang.

A)  $\frac{\sqrt{2}}{2}$ ;      B)  $-\frac{\sqrt{2}}{2}$ ;      C)  $\frac{1}{2}$ ;      D)  $-\frac{\sqrt{3}}{2}$ ;      E)  $\sqrt{2}$ .

35.  $\frac{1 + \cos \frac{\alpha}{2} - \sin \frac{\alpha}{2}}{1 - \cos \frac{\alpha}{2} - \sin \frac{\alpha}{2}}$  ni soddallashtiring.

A)  $\operatorname{tg} \frac{\alpha}{2}$ ;      B)  $\operatorname{ctg} \frac{\alpha}{2}$ ;      C)  $\operatorname{tg} \frac{\alpha}{4}$ ;      D)  $\operatorname{ctg} \frac{\alpha}{4}$ ;      E)  $-\operatorname{ctg} \frac{\alpha}{4}$ .

36\*.  $\operatorname{tg} 20^\circ \cdot \operatorname{tg} 40^\circ \cdot \operatorname{tg} 60^\circ \cdot \operatorname{tg} 80^\circ$  ni hisoblang.

A) 1;      B) 2;      C) 3;      D)  $\sqrt{3}$ ;      E)  $\frac{1}{\sqrt{3}}$ .

37.  $\frac{\sin \alpha + \sin 3\alpha + \sin 5\alpha}{\cos \alpha + \cos 3\alpha + \cos 5\alpha}$  ni soddallashtiring.

A)  $\operatorname{tg} 3\alpha$ ;      B)  $\operatorname{tg} 2\alpha$ ;      C)  $\operatorname{ctg} 3\alpha$ ;      D)  $\operatorname{ctg} 2\alpha$ ;      E)  $\operatorname{tg}^2 3\alpha$ .

38\*.  $8 \cos 10^\circ \cos 20^\circ \cos 40^\circ$  ni soddallashtiring.

- A)  $\frac{1}{8}$ ; B) 1; C)  $10^\circ$ ; D)  $\text{ctg}10^\circ$ ; E)  $-\frac{1}{8}$ .

39\*.  $\frac{3\sin^2\alpha + \cos^4\alpha}{1 + \sin^2\alpha + \sin^4\alpha}$  ni soddalashtiring.

- A) 1; B) 3; C)  $\text{ctg}^2\alpha$ ; D)  $\text{tg}^2\alpha$ ; E)  $2\sin\alpha$ .

40.  $\alpha = \sin 189^\circ$ ,  $b = \cos 42^\circ$ ,  $c = \cos 88^\circ$  sonlarini kamayish tartibida yozing.

- A)  $b > c > a$ ; B)  $b > a > c$ ; C)  $a > b > c$ ; D)  $a > c > b$ ;

- E)  $c > b > a$ .

41\*.  $\frac{4\cos^2 2\alpha - 4\cos^2 \alpha + 3\sin^2 \alpha}{4\cos^2\left(\frac{5\pi}{2} - \alpha\right) - \sin^2 2(\alpha - \pi)}$  ni soddalashtiring.

- A)  $\text{tg}^2 2\alpha - 3$ ; B)  $4\cos 2\alpha - 1$ ; B)  $\frac{2\cos 2\alpha}{\sin^2 \alpha}$ ; D)  $\frac{8\cos 2\alpha + 1}{2\sin 2\alpha - 2}$ ;

- E)  $\frac{3\cos \alpha}{4\sin^2 \alpha}$ .

42.  $\log_5 \text{tg} 36^\circ + \log_5 \text{tg} 54^\circ$  ni hisoblang.

- A) 0; B) 1; C)  $\sqrt{3}$ ; D)  $\sqrt{2}$ ; E)  $\emptyset$ .

43.  $\log_2 \cos 20^\circ + \log_2 \cos 40^\circ + \log_2 \cos 60^\circ + \log_2 \cos 80^\circ$  ni hisoblang.

- A)  $\frac{1}{2}$ ; B) 1; C) 0; D) -3; E) -4.

44. Quyidagi funksiyalardan qaysi biri toq?

- A)  $f(x) = x\sin 3x$ ; B)  $f(x) = 2x\text{tg} 2x$ ; C)  $f(x) = x^3 - \sin 2x$ ;

- D)  $f(x) = 3 - x\text{ctg} 2x$ ; E)  $f(x) = 2 + x\cos x$ .

45. Berilgan funksiyalar orasida qaysilari juft?

1)  $f(x) = \frac{2+4\cos 2x}{x^2-4}$ ; 2)  $f(x) = \frac{3\sin 2x}{1-\cos 5x}$ ;

3)  $f(x) = \frac{3+4\cos x}{2\text{tg} 2x}$ ; 4)  $f(x) = \frac{\cos 4x - x^4}{x^2 - \cos 2x}$ .

- A) 1 va 4; B) 1 va 2; C) faqat 1; D) 2 va 3; E) 1, 2 va 3.

46.  $y = \cos 2x \cos x + \sin x \sin 2x$  funksiyaning eng kichik musbat davrini toping.

- A)  $2\pi$ ;      B)  $\pi$ ;      C)  $3\pi$ ;      D)  $4\pi$ ;      E)  $6\pi$ .

47.  $y = 1 - 2\cos\left(x - \frac{\pi}{6}\right)$  funksiyaning eng kichik musbat davrini toping.

- A)  $\frac{\pi}{3}$ ;      B)  $2\pi$ ;      C)  $\frac{11\pi}{6}$ ;      D)  $\frac{13\pi}{6}$ ;      E)  $\pi$ .

48.  $y = \sin(-2x)\cos 2x$  funksiyaning eng kichik musbat davrini toping.

- A)  $\frac{\pi}{3}$ ;      B)  $\frac{\pi}{2}$ ;      C)  $2\pi$ ;      D)  $\pi$ ;      E)  $4\pi$ .

49.  $y = \sin^2\left(3x - \frac{\pi}{6}\right) - \cos^2\left(\frac{\pi}{6} - 3x\right)$  funksiyaning eng kichik musbat davrini toping.

- A)  $2\pi$ ;      B)  $\frac{\pi}{2}$ ;      C)  $\frac{\pi}{3}$ ;      D)  $\pi$ ;      E)  $4\pi$ .

50. Quyidagi funksiyalardan qaysi birining eng kichik musbat davri  $2\pi$  ga teng?

A)  $y = \frac{2\operatorname{tg}x}{1-\operatorname{tg}^2x}$ ; B)  $y = 1 - \cos^2 x$ ; C)  $y = \sin^2 x - \cos^2 x$ ;

D)  $y = \operatorname{ctg} 2x \cdot \sin 2x$ ; E)  $y = \sin \frac{x}{2} \cos \frac{x}{2}$ .

51.  $f(x) = \frac{1}{\sin(3x-2)}$  funksiyaning aniqlanish sohasini toping.

A)  $x \in R, x \neq k\pi, k \in Z$ ; B)  $x \in R, x \neq \frac{2}{3} + \frac{k\pi}{3}, k \in Z$ ;

C)  $x \in R, x \neq \frac{\pi}{2} + k\pi, k \in Z$ ; D)  $x \in R, x \neq \frac{k\pi}{3}, k \in Z$ ;

E)  $x \in R, x \neq 2k\pi, k \in Z$ .

52.  $y = -2\cos x$  funksiyaning qiymatlar to'plamini toping.

A)  $[-1; 1]$ ; B)  $[-2; 2]$ ; C)  $\left[\frac{1}{2}; 1\right]$ ; D)  $\left[-\frac{1}{2}; \frac{1}{2}\right]$ ; E)  $[0; 2]$ .

53.  $y = 5 - \sin 2x$  funksiyaning qiymatlar to'plamini toping.

A)  $[-1; 1]$ ; B)  $[-3; 3]$ ; C)  $[4; 6]$ ; D)  $[0; 4]$ ; E)  $[-1; 6]$ .

54.  $y = 2 + \sqrt{\cos\left(x + \frac{\pi}{3}\right)}$  funksiyaning qiymatlar to'plamini toping.



A) [2; 3]; B) [-2; 2]; C) [0; 2]; D) [0; 3]; E) [1; 3].

55.  $y = 2 + 2\cos 8x + 7\sin^2 4x$  funksiyaning qiymatlar to'plamini toping.

A) [2; 11]; B) [2; 9]; C) [0; 2]; D) [-3; 4]; E) [4; 7].

56.  $y = 12\sin x - 5\cos x + 1$  funksiyaning qiymatlar to'plamini toping.

A) [0; 8]; B) [1; 8]; C) [-12; 0]; D) [-12; 14]; E) [-16; 14].

57.  $a$  ning qanday qiymatlarida  $\arccos(5 - 4a)$  ifoda ma'noga ega?

A) [-1; 1]; B) [1; 1.5]; C) [4; 6]; D)  $(-\infty; -1] \cup [1; +\infty)$ ;

E)  $(-\infty; 4] \cup [6; +\infty)$ .

58.  $\arcsin a$  quyidagi qiymatlardan qaysilarini qabul qilishi mumkin?

1)  $\frac{\pi}{4}$ .      2)  $\frac{\pi}{8}$ .      3)  $-\frac{\pi}{8}$ .      4)  $-\sqrt{2}$ .

A) 1) va 2); B) 1) va 4); C) faqat 1); D) faqat 2); E) Hammasi.

59.  $\arctg a$  quyidagi qiymatlardan qaysilarini qabul qilishi mumkin?

1) 0;      2)  $-\frac{\pi}{3}$ ;      3)  $\sqrt{5}$ ;      4)  $-\frac{\pi}{2}$ .

A) hammasini; B) faqat 1 va 2; C) 1; 2; 3; D) 3; 4; E) faqat 2.

60.  $\arcsin 0 - \arccos 0$  ni hisoblang.

A) 0;      B)  $\pi$ ;      C)  $-\frac{\pi}{2}$ ;      D)  $\frac{\pi}{2}$ ;      E)  $-\pi$ .

61.  $2\arccos\left(-\frac{\sqrt{3}}{2}\right) + \arcsin\frac{\sqrt{2}}{2}$  ni hisoblang.

A)  $\frac{23\pi}{12}$ ;      B)  $\frac{5\pi}{6}$ ;      C)  $-\frac{17\pi}{12}$ ;      D)  $\frac{5\pi}{12}$ ;      E)  $-\frac{\pi}{12}$ .

62.  $\sin(2\arcsin 0,8)$  ni hisoblang.

A) 0,8;      B) 0,16;      C) 0,96;      D)  $\frac{1}{4}$ ;      E)  $\frac{1}{8}$ .

63.  $\cos(2\arctg 3)$  ni hisoblang.

A) 0,8;      B) 0,16;      C) 0,6;      D)  $\frac{2}{3}$ ;      E) -0,8.

64.  $\arctg 3 - \arctg \frac{1}{2}$  ni hisoblang.

- A) 1;      B) 1.5;      C) 2,5;      D)  $\frac{1}{2}$ ;      E)  $\frac{2}{3}$ .

65\*.  $\arcsin\left(\cos\frac{\pi}{9}\right)$  ni hisoblang.

- A)  $\frac{\pi}{9}$ ;      B)  $\frac{7\pi}{18}$ ;      C)  $\frac{11\pi}{18}$ ;      D)  $\frac{\pi}{2}$ ;      E)  $\frac{2\pi}{9}$ .

66.  $m = \arccos 0,9$  va  $n = \arccos(-0,7)$  va  $p = \arccos(-0,2)$  sonlar-ni o'sib borish tartibida yozing.

- A)  $n < p < m$ ; B)  $m < p < n$ ; C)  $p < n < m$ ; D)  $n < m < p$ ;  
E)  $m < n < p$ .

67.  $m = \arctg 2$ ,  $n = \arccos 0$  va  $\pi = \arcsin 0,5$  sonlarni kamayish tartibida yozing.

- A)  $n > m > p$ ; B)  $m > n > p$ ; C)  $n > p > m$ ; D)  $m > p > n$ ;  
E)  $p > m > n$ .

68\*.  $\arcsin\left(\sin\frac{5\pi}{8}\right) + \arccos\left(\cos\frac{8\pi}{7}\right)$  ni hisoblang.

- A)  $\frac{69}{56}\pi$ ;      B)  $\frac{13}{56}\pi$ ;      C)  $\frac{99}{56}\pi$ ;      D)  $\frac{83}{56}\pi$ ;      E)  $\frac{85}{56}\pi$ .

69\*.  $\cos\left(\arcsin\frac{7}{25} + \arccos\frac{5}{13}\right)$  ni hisoblang.

- A)  $\frac{204}{325}$ ;      B)  $\frac{216}{325}$ ;      C)  $\frac{34}{325}$ ;      D)  $\frac{36}{325}$ ;      E)  $\frac{35}{325}$ .

## TRIGONOMETRIK TENGLAMALAR VA TENGSIZLIKLAR

### 1-§. Trigonometrik tenglamalar

Noma'lumi trigonometrik funksiya ishorasi ostida bo'lgan tenglama *trigonometrik tenglama* deb ataladi.

$\sin x = a$  ( $|a| \leq 1$ ),  $\cos x = a$  ( $|a| \leq 1$ ),  $\operatorname{tg} x = a$ ,  $\operatorname{ctg} x = a$  ( $a \in R$ ) tenglamalar eng sodda trigonometrik tenglamalarga misol bo'la oladi.

**1.  $\sin x = a$  ( $|a| \leq 1$ ) tenglama.** Bu tenglamani yechish, ushbu ikki  $y = \sin x$  va  $y = a$  funksiyalar kesishish nuqtalarining absissalarini topishdan iboratdir (133-rasm). Ko'rinib turibdiki,  $\sin x = a$  tenglama ikki guruh ildizlarga ega:

1)  $x = \arcsin a + 2k\pi$ ,  $k \in Z$  ( $Z$  — butun sonlar to'plami),

2)  $x = \pi - \arcsin a + 2k\pi = -\arcsin a + (2k + 1)\pi$ ,  $k \in Z$ .

Ikkala guruh ildizlarini bitta

$$x = (-1)^k \arcsin a + k\pi \quad (1)$$

formula bilan ifodalash mumkin, bunda  $k \in Z$ .

#### Xususiy hollar

1. Agar  $\sin x = 1$  bo'lsa, u holda  $x = \frac{\pi}{2} + 2k\pi$ ,  $k \in Z$ .

2. Agar  $\sin x = -1$  bo'lsa, u holda  $x = -\frac{\pi}{2} + 2k\pi$ ,  $k \in Z$ .

3. Agar  $\sin x = 0$  bo'lsa, u holda  $x = k\pi$ ,  $k \in Z$ .

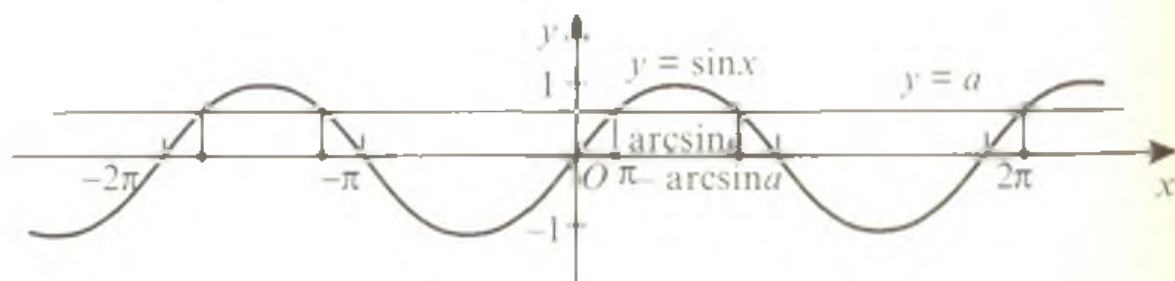

133-rasm

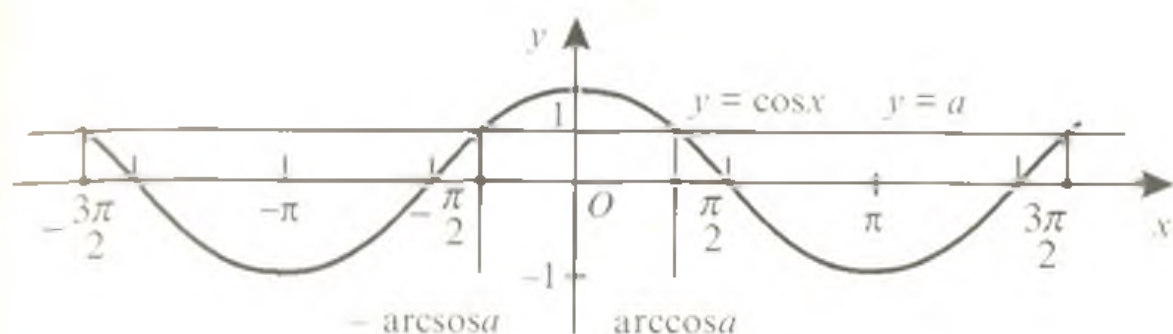

134-rasm

Tenglamalarni yechayotganda  $\arcsin(-a) = -\arcsin a$  ekanligi inobatga olinadi.

1-misol.  $\sin \frac{2}{3}x = \frac{1}{2}$  tenglamani yeching.

Yechilishi. (1) formulaga ko'ra,  $\frac{2}{3}x = (-1)^k \arcsin \frac{1}{2} + k\pi \Leftrightarrow$   
 $\Leftrightarrow \frac{2}{3}x = (-1)^k \frac{\pi}{6} + k\pi \Rightarrow x = (-1)^k \frac{\pi}{4} + \frac{3}{2}k\pi, k \in Z.$

Javob:  $x = (-1)^k \frac{\pi}{4} + \frac{3}{2}k\pi, k \in Z.$

2-misol.  $\sin 3x + \frac{\sqrt{2}}{2} = 0$  tenglamani yeching.

Yechilishi.  $\sin 3x + \frac{\sqrt{2}}{2} = 0 \Leftrightarrow \sin 3x = -\frac{\sqrt{2}}{2} \Leftrightarrow 3x =$   
 $= (-1)^k \arcsin\left(-\frac{\sqrt{2}}{2}\right) + k\pi = (-1)^k \left(-\frac{\pi}{4}\right) + k\pi = (-1)^{k+1} \frac{\pi}{4} + k\pi \Rightarrow$   
 $\Rightarrow x = (-1)^{k+1} \frac{\pi}{12} + \frac{k\pi}{3}, k \in Z.$

Javob:  $x = (-1)^{k+1} \frac{\pi}{12} + \frac{k\pi}{3}, k \in Z.$

**1.2.  $\cos x = a$  ( $|a| \leq 1$ ) tenglama.** Bu tenglamaning har bir ildizini  $y = \cos x$  kosinusoidaning  $y = a$  to'g'ri chiziq bilan kesishish nuqtalarining absissasi deb qarash mumkin (134-rasm). Agar  $|a| > 1$  bo'lsa,  $y = \cos x$  kosinusoida  $y = a$  to'g'ri chiziq bilan kesishmaydi.

Bu holda  $\cos x = a$  tenglama ildizga ega bo'lmaydi.

Chizmadan ko'rinib turibdiki,  $\cos x = a$  tenglama  $x = \arccos a + 2k\pi$  va  $x = -\arccos a + 2k\pi$  ildizlarga ega. Bu ikkala ildizlar guruhini bir formula bilan berish mumkin:

$$x = \pm \arccos a + 2k\pi, k \in Z. \quad (2)$$

### Xususiy hollar

1. Agar  $\cos x = 0$  bo'lsa, u holda  $x = \frac{\pi}{2} + k\pi$ ,  $k \in Z$ .

2. Agar  $\cos x = 1$  bo'lsa, u holda  $x = 2k\pi$ ,  $k \in Z$ .

3. Agar  $\cos x = -1$  bo'lsa, u holda  $x = \pi + 2k\pi$ ,  $k \in Z$ .

Tenglamalarning ildizlarini topayotganda  $\arccos(-a) = \pi - \arccos a$  ekanligini yodda tutmoq kerak.

3-misol.  $\cos 5x = -\frac{1}{2}$  tenglamani yeching.

Yechilishi. (2) formulaga ko'ra,  $5x = \pm \left( \pi - \arccos \frac{1}{2} \right) + 2k\pi = \pm \left( \pi - \frac{\pi}{3} \right) + 2k\pi = \pm \frac{2\pi}{3} + 2k\pi$ ,  $k \in Z$ .  $x = \pm \frac{2\pi}{15} + \frac{2}{5}k\pi$ ,  $k \in Z$ .

Javob:  $x = \pm \frac{2\pi}{15} + \frac{2}{5}k\pi$ ,  $k \in Z$ .

4-misol.  $\cos 2x = \frac{\sqrt{3}}{2}$  tenglama  $[0; 2\pi]$  oraliqda nechta ildizga ega?

Yechilishi. (2) formulaga ko'ra  $2x = \pm \arccos \frac{\sqrt{3}}{2} + 2k\pi = \pm \frac{\pi}{6} + 2k\pi$ ,  $k \in Z$ ;  $x = \pm \frac{\pi}{12} + k\pi$ ,  $k \in Z$  ildizlar uchun topilgan

ifodada  $k = 0$ ;  $k = 1$ ;  $k = 2$  deb,  $[0; 2\pi]$  oraliqqa tegishli  $x_1 = \frac{\pi}{12}$ ;

$x_2 = \frac{11\pi}{12}$ ;  $x_3 = \frac{13\pi}{12}$ ;  $x_4 = \frac{23\pi}{12}$  ildizlarni topamiz.

Javob: 4 ta.

**1.3.  $\operatorname{tg} x = a$  va  $\operatorname{ctg} x = a$  tenglamalar.**  $\operatorname{tg} x = a$  ( $a \in R$ ) tenglama ildizlari

$$x = \operatorname{arctg} a + k\pi, k \in Z \quad (3)$$

formula bilan beriladi. Shunga o'xshash,  $\operatorname{ctg} x = a$  ( $a \in R$ ) tenglama ildizlari

$$x = \operatorname{arctg} a + k\pi, k \in Z \quad (4)$$

munosabat yordamida aniqlanadi. (3) va (4) formulalarning o'rinli ekanligi 135- va 136-rasmlarda yaqqol tasvirlangan.

Tenglamalarning ildizlarini topayotganda  $\operatorname{arctg}(-a) = -\operatorname{arctg} a$  va  $\operatorname{arctg}(-a) = \pi - \operatorname{arctg} a$  ekanligini nazarda tutish kerak.

5-misol.  $\operatorname{tg} \frac{x}{4} = -1$  tenglamani yeching.

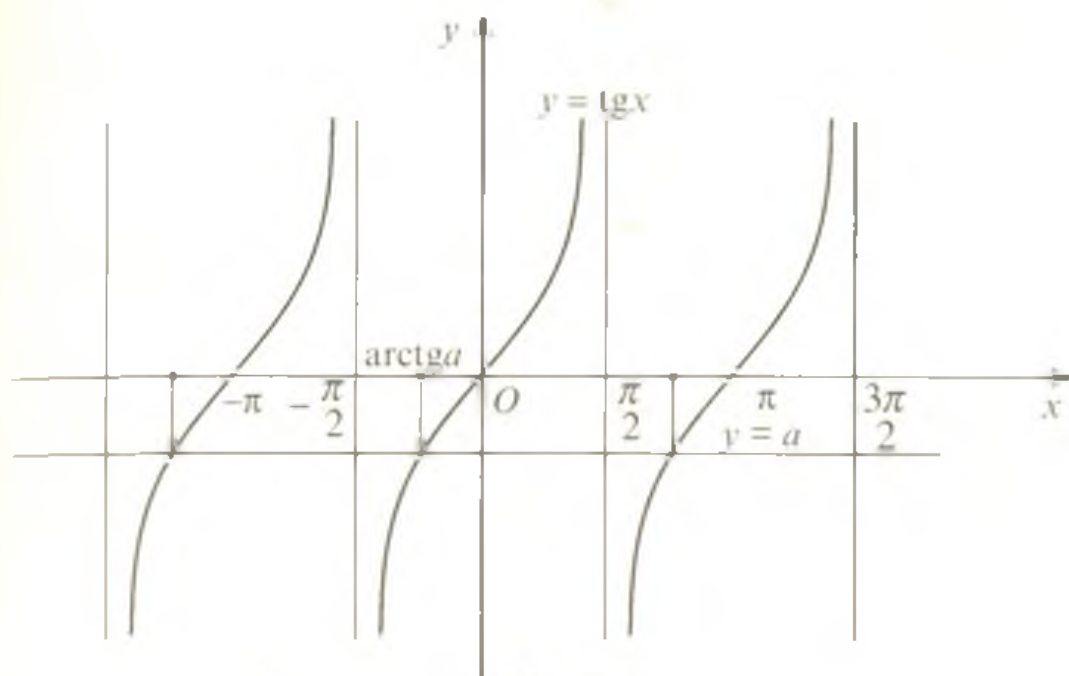

135-rasm

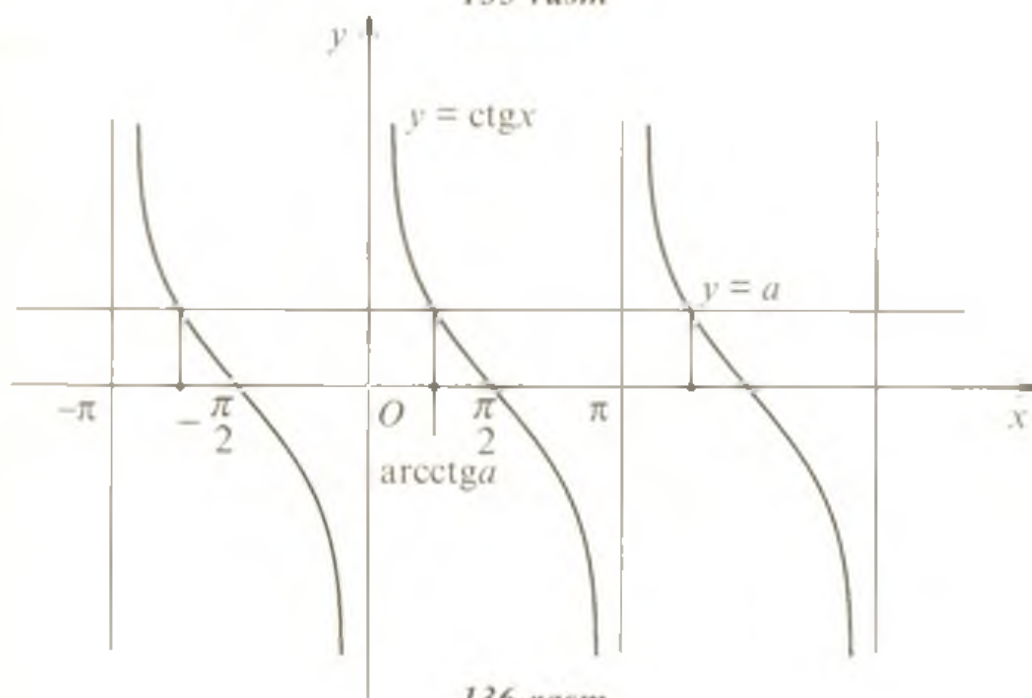

136-rasm

Yechilishi.  $\frac{x}{4} = \arctg(-1) + k\pi \Leftrightarrow \frac{x}{4} = -\arctg 1 + k\pi \Leftrightarrow \frac{x}{4} = -\frac{\pi}{4} + k\pi \Rightarrow [x = -\pi + 4k\pi, k \in \mathbb{Z}.$

Javob:  $x = -\pi + 4k\pi, k \in \mathbb{Z}.$

6-misol.  $\text{ctg} \frac{3}{2}x = 5$  tenglamani yeching.

Yechilishi.  $\frac{3}{2}x = \operatorname{arctg}5 + k\pi \Leftrightarrow x = \frac{2}{3}\operatorname{arctg}5 + \frac{2}{3}k\pi, k \in \mathbb{Z}$ .

Javob:  $x = \frac{2}{3}\operatorname{arctg}5 + \frac{2}{3}k\pi, k \in \mathbb{Z}$ .

## 2-§. Trigonometrik tenglamalarning ayrim turlari va ularni yechish usullari

**2.1 Algebraik tenglamalarga keltiriladigan tenglamalar.** Bu turkumdagi tenglamalarga funksiya belgisi ostidagi bitta noma'lum ifodaga nisbatan faqat bir funksiyaga keltiriladigan tenglamalar kiradi.

Masalan,

$$a \sin^2 x + b \sin x + c = 0; \quad a \cos^2 x + b \cos x + c = 0;$$

$$a \operatorname{tg}^2 3x + b \operatorname{tg} 3x + c = 0; \quad a \operatorname{ctg}^2 2x + b \operatorname{ctg} 2x + c = 0$$

kabi tenglamalar algebraik tenglamalarga keltiriladigan tenglamalar hisoblanadi. Ularda  $\sin x = y$ ,  $\cos x = z$ ,  $\operatorname{tg} 3x = t$ ,  $\operatorname{ctg} 2x = u$  almashtirishlar kiritib, mos ravishda  $ay^2 + by + c = 0$ ,  $az^2 + bz + c = 0$ ,  $at^2 + bt + c = 0$  va  $au^2 + bu + c = 0$  algebraik tenglamalarga ega bo'lamiz. Ularning har birini yechib,  $\sin x$ ,  $\cos x$ ,  $\operatorname{tg} 3x$ ,  $\operatorname{ctg} 2x$  larni topamiz.

$$a \sin^2 x + b \cos x + c = 0; \quad a \cos^2 x + b \sin x + c = 0;$$

$$a \operatorname{tg}^2 x + b \operatorname{ctg} x = 0$$

tenglamalar ko'rinishidan algebraik tenglamalar bo'lmasa-da, ularni ham algebraik tenglamalarga keltirish mumkin:

$$a \sin^2 x + b \cos x + c = 0 \Leftrightarrow a \cos^2 x - b \cos x - (a + c) = 0.$$

$$a \cos^2 x + b \sin x + c = 0 \Leftrightarrow a \sin^2 x - b \sin x - (a + c) = 0.$$

$$a \operatorname{tg} x + b \operatorname{ctg} x = 0 \Leftrightarrow a \operatorname{tg} x + \frac{b}{\operatorname{tg} x} = 0.$$

1-misol.  $2\sin^2 x - 7\cos x - 5 = 0$  tenglamaning  $x \in [0; 2\pi]$  oraliqdagi ildizlarini toping.

Yechilishi.  $2\sin^2 x - 7\cos x - 5 = 0 \Leftrightarrow 2(1 - \cos^2 x) - 7\cos x - 5 = 0$

$$\Leftrightarrow 2\cos^2 x + 7\cos x + 3 = 0 \Leftrightarrow [\cos x = t] \Leftrightarrow 2t^2 + 7t + 3 = 0 \Rightarrow$$

$$\Rightarrow \begin{cases} t_1 = -3, \\ t_2 = -\frac{1}{2}; \end{cases} \Rightarrow \begin{cases} \cos x = -3 < -1 \Rightarrow x \in \emptyset, \\ \cos x = -\frac{1}{2} \Rightarrow x = \pm \frac{2}{3}\pi + 2k\pi, k \in \mathbb{Z}. \end{cases}$$

$k = 0$  va  $k = 1$  qiymatlar berib, ko'rsatilgan oraliqdagi ildizlarni topamiz:

$$x_0 = \frac{2\pi}{3}; x_1 = \frac{4\pi}{3}.$$

Javob:  $\frac{2\pi}{3}; \frac{4\pi}{3}$ .

2-misol.  $\cos 2x + 3\sin x = 2$  tenglamani yeching.

Yechilishi.  $\cos 2x + 3\sin x = 2 \Leftrightarrow \cos^2 x - \sin^2 x + 3\sin x = 2 \Leftrightarrow 1 - \sin^2 x - \sin^2 x + 3\sin x - 2 = 0 \Leftrightarrow 2\sin^2 x - 3\sin x +$

$$+ 1 = 0 \Leftrightarrow [\sin x = t] \Leftrightarrow 2t^2 - 3t + 1 = 0 \Rightarrow \begin{cases} t_1 = \frac{1}{2}, \\ t_2 = 1; \end{cases} \Rightarrow \begin{cases} \sin x = \frac{1}{2}, \\ \sin x = 1. \end{cases}$$

$$x = (-1)^k \frac{\pi}{6} + k\pi, k \in Z; \quad x = \frac{\pi}{2} + 2k\pi, k \in Z.$$

Javob:  $(-1)^k \frac{\pi}{6} + k\pi, \frac{\pi}{2} + 2k\pi, (k \in Z)$ .

3-misol.  $\operatorname{tg} x + \operatorname{ctg} x = 2$  tenglama  $[0; 2\pi]$  oraliqda nechta ildizga ega?

Yechilishi. Berilgan tenglama o'zgaruvchi  $x$  ning  $x = \frac{\pi}{2} + k\pi$  va  $x = k\pi$  qiymatlaridan boshqa barcha qiymatlarida aniqlanganligini hisobga olib, tenglamani yechamiz:

$$\operatorname{tg} x + \operatorname{ctg} x = 2 \Leftrightarrow \operatorname{tg} x + \frac{1}{\operatorname{tg} x} = 2 \Leftrightarrow \operatorname{tg}^2 x - 2\operatorname{tg} x + 1 = 0 \Leftrightarrow$$

$$|\operatorname{tg} x = t| \Leftrightarrow t^2 - 2t + 1 = 0 \Leftrightarrow [t_1 = t_2 = 1] \Leftrightarrow \operatorname{tg} x = 1 \Rightarrow x = \frac{\pi}{4} + k\pi, k \in Z.$$

Ko'rsatilgan oraliqqa tegishli ildizlar soni  $k$  ga tegishli qiymatlar berib, yoki trigonometrik doira tasviridan foydalanib topiladi:

$$k = 0, k = 1, x_0 = \frac{\pi}{4}; x_1 = \frac{5\pi}{4}.$$

Javob: 2 ta.

**2.2. Bir jinsli tenglamalar.**  $a \sin x + b \cos x = 0$ ;  $a \sin^2 x + b \sin x \cos x + c \cos^2 x = 0$ ;  $a \sin^3 x + b \sin^2 x \cos x + c \sin x \cos^2 x + d \cos^3 x = 0$ ,  $a, b, c, d \in R$  kabi tenglamalar  **$\sin x$  va  $\cos x$  ga nisbatan bir jinsli tenglamalar** deyiladi. Bunday tenglamalarning barcha hadlarida  $\sin x$  va  $\cos x$  ning daraja ko'rsatkichlari yig'indisi bir xildir. Bu yig'indi bir jinsli tenglamaning **darajasi** deyiladi. Keltirilgan tenglamalar mos ravishda birinchi, ikkinchi, uchinchi dara-



jali tenglamalardir. Bunday tenglamalar  $\cos^n x \neq 0$  ga ( $n$  — tenglama darajasi) bo'lib yuborish natijasida  $\operatorname{tg} x$  ga nisbatan algebraik tenglamaga keltiriladi.

$a \sin^2 x + b \sin x \cos x + c \cos^2 x = d$  shaklidagi tenglama o'ng tomonini  $\sin^2 x + \cos^2 x = 1$  ga ko'paytirish yordamida bir jinsli tenglama shakliga keltiriladi.

4-misol.  $4 \sin^2 x + 2 \sin x \cos x = 3$  tenglamani yeching.

Yechilishi.  $4 \sin^2 x + 2 \sin x \cos x = 3 \Leftrightarrow 4 \sin^2 x + 2 \sin x \cos x = 3(\sin^2 x + \cos^2 x) \Leftrightarrow \sin^2 x + 2 \sin x \cos x - 3 \cos^2 x = 0$  tenglamaning har ikkala tomonini  $\cos^2 x \neq 0$  ga bo'lamiz:

$$\operatorname{tg}^2 x + 2 \operatorname{tg} x - 3 = 0 \Rightarrow \begin{cases} \operatorname{tg} x = -3 \\ \operatorname{tg} x = 1 \end{cases} \Rightarrow \begin{cases} x = -\operatorname{arctg} 3 + k\pi, k \in \mathbb{Z}; \\ x = \frac{\pi}{4} + k\pi, k \in \mathbb{Z}. \end{cases}$$

Javob:  $x = -\operatorname{arctg} 3 + k\pi, \frac{\pi}{4} + k\pi, k \in \mathbb{Z}$ .

5-misol.  $\sin x - \sqrt{3} \cos x = 0$  tenglamani yeching.

Yechilishi. Bunday tenglamalarni yechishda tenglamaning ikkala qismi  $\cos x$  ga bo'linadi. Tenglamani noma'lum miqdor tarkibida bo'lgan ifodaga bo'lganda ildizlar yo'qolishi mumkin. Shuning uchun  $\cos x = 0$  tenglamaning ildizlari bo'lish-bo'lmasligini tekshirib ko'rish kerak. Agar  $\cos x = 0$  bo'lsa, berilgan tenglamadan  $\sin x = 0$  ekanligi kelib chiqadi. Lekin  $\sin x$  va  $\cos x$  lar bir vaqtda nolga teng bo'la olmaydi. Demak, berilgan tenglamani  $\cos x$  ga bo'lishda tenglama ildizlari yo'qolmaydi. Shunday qilib,

$$\sin x - \sqrt{3} \cos x = 0 \Leftrightarrow \sin x = \sqrt{3} \cos x \Leftrightarrow \operatorname{tg} x = \sqrt{3} \Rightarrow x = \frac{\pi}{3} + k\pi, k \in \mathbb{Z}.$$

Javob:  $\frac{\pi}{3} + k\pi, k \in \mathbb{Z}$ .

### 2.3. Ko'paytuvchilarga ajratib yechiladigan tenglamalar.

Ko'pgina trigonometrik tenglamalarni yechishda algebraik ifodalarni ko'paytuvchilarga ajratishning umumiy ko'paytuvchini qavsdan tashqariga chiqarish, guruhlash usuli bilan ko'paytuvchilarga ajratish, qisqa ko'paytirish formulalaridan foydalanib ko'paytuvchilarga ajratish kabi usullardan foydalaniladi.

6-misol.  $(1 + \cos 4x) \sin 2x = \cos^2 2x$  tenglamani yeching.

Yechilishi.  $\cos^2 2x$  ni tenglamaning chap qismiga o'tkazib, darajani pasaytirish formulasidan foydalanamiz va hosil bo'lgan ifodani ko'paytuvchilarga ajratamiz:

$$(1 + \cos 4x) \sin 2x = \cos^2 2x \Leftrightarrow (1 + \cos 4x) \sin 2x - \frac{1 + \cos 4x}{2} = 0 \Leftrightarrow$$

$$\Leftrightarrow (1 + \cos 4x)(2 \sin 2x - 1) = 0.$$

1)  $(1 + \cos 4x) = 0 \Leftrightarrow \cos 4x = -1 \Rightarrow 4x = \pi + 2k\pi \Rightarrow x = \frac{\pi}{4} + \frac{k\pi}{2};$   
 $k \in Z.$

2)  $2 \sin 2x - 1 = 0 \Rightarrow \sin 2x = \frac{1}{2} \Rightarrow 2x = (-1)^k \frac{\pi}{6} + k\pi \Rightarrow x =$   
 $= (-1)^k \frac{\pi}{12} + \frac{k\pi}{2}, k \in Z.$

Javob:  $\frac{\pi}{4} + \frac{k\pi}{2}, (-1)^k \frac{\pi}{12} + \frac{k\pi}{2}, k \in Z.$

7-misol.  $3(1 - \sin x) + \sin^4 x = 1 + \cos^4 x$  tenglamani yeching.

Yechilishi.  $3(1 - \sin x) + \sin^4 x = 1 + \cos^4 x \Leftrightarrow 3(1 - \sin x) = 1 +$   
 $+ \cos^4 x - \sin^4 x \Leftrightarrow 3(1 - \sin x) = 1 + (\cos^2 x + \sin^2 x)(\cos^2 x - \sin^2 x) \Leftrightarrow$   
 $\Leftrightarrow 3(1 - \sin x) = 1 + \cos^2 x \Leftrightarrow 3(1 - \sin x) = 2\cos^2 x \Leftrightarrow 3(1 - \sin x) =$   
 $= 2(1 - \sin^2 x) \Leftrightarrow 3(1 - \sin x) - 2(1 - \sin x)(1 + \sin x) = 0 \Leftrightarrow$   
 $\Leftrightarrow (1 - \sin x)(3 - 2(1 + \sin x)) = 0 \Leftrightarrow (1 - \sin x)(1 - 2\sin x) = 0 \Rightarrow$

$$\Rightarrow \begin{cases} \sin x = 1 \\ \sin x = \frac{1}{2} \end{cases} \Rightarrow \begin{cases} x = \frac{\pi}{2} + 2k\pi, k \in Z; \\ x = (-1)^k \frac{\pi}{6} + 2k\pi, k \in Z. \end{cases}$$

Javob:  $\frac{\pi}{2} + 2k\pi, (-1)^k \frac{\pi}{6} + k\pi, k \in Z.$

8-misol.  $\sin 3x + \sin 5x = \sin 4x$  tenglamaning nechta ildizi

$|x| \leq \frac{\pi}{2}$  tengsizlikni qanoatlantiradi?

Yechilishi. Tenglamani uning chap qismini ko'paytma shakliga keltirib yechamiz:

$$\sin 3x + \sin 5x = \sin 4x \Leftrightarrow 2 \sin \frac{3x+5x}{2} \cos \frac{3x-5x}{2} = \sin 4x \Leftrightarrow$$

$$\Leftrightarrow 2 \sin 4x \cos x - \sin 4x = 0 \Leftrightarrow \sin 4x(2 \cos x - 1) = 0 \Rightarrow \begin{cases} \sin 4x = 0, \\ \cos x = \frac{1}{2}, \end{cases} \Rightarrow$$

$$\Rightarrow \begin{cases} 4x = \frac{k\pi}{4}, & k \in Z, \\ x = \pm \frac{\pi}{3} + 2k\pi, & k \in Z. \end{cases}$$

$k = 0; \pm 1; \pm 2$  qiymatlar uchun tenglamaning  $|x| \leq \frac{\pi}{2}$  shartni qanoatlantiruvchi  $x = \pm \frac{\pi}{2}; \pm \frac{\pi}{4}; \pm \frac{\pi}{3}; 0$  ildizlarini ko'rsatish mumkin.  
Javob: 7 ta.

**2.4. Bir ismli trigonometrik funksiyalarning tenglik shartlaridan foydalanib yechiladigan tenglamalar.** Bunday tenglamalarni yechish bir ismli trigonometrik funksiyalarning tengligi shartlariga, ya'ni  $\alpha$  va  $\beta$  burchaklarning  $\sin \alpha = \sin \beta$ ,  $\cos \alpha = \cos \beta$ ,  $\operatorname{tg} \alpha = \operatorname{tg} \beta$  tengliklarni qanoatlantiruvchi shartlariga asoslanadi.

**1-teorema.** Ikki burchakning sinuslari teng bo'lishi uchun quyidagi shartlardan birining bajarilishi zarur va yetarlidir: bu burchaklar ayirmasi  $\pi$  ni juft songa ko'paytirilganiga teng bo'lishi kerak yoki bu burchaklar yig'indisi  $\pi$  ni toq songa ko'paytirilganiga teng bo'lishi kerak, ya'ni  $\alpha - \beta = 2k\pi$  yoki  $\alpha + \beta = (2k + 1)\pi$ ,  $k \in Z$  bo'lsa,  $\sin \alpha = \sin \beta$  bo'ladi.

**2-teorema.** Ikki burchakning kosinuslari teng bo'lishi uchun quyidagi shartlardan birining bajarilishi zarur va yetarlidir: bu burchaklar ayirmasi yoki yig'indisi  $\pi$  ni juft songa ko'paytirilganida teng bo'lishi kerak, ya'ni  $\alpha - \beta = 2k\pi$  yoki  $\alpha + \beta = 2k\pi$ ,  $k \in Z$  bo'lsa,  $\cos \alpha = \cos \beta$  bo'ladi.

**3-teorema.** Ikki burchakning tangenslari teng bo'lishi uchun quyidagi ikki shartning bir paytda bajarilishi zarur va yetarlidir: bu ikki burchakning tangenslari mavjud bo'lishi va bu burchaklar ayirmasi  $\pi$  ni butun songa ko'paytirilganiga teng bo'lishi kerak, ya'ni  $\alpha \neq \frac{\pi}{2} + k\pi$ ,  $\beta \neq \frac{\pi}{2} + k\pi$ ,  $\alpha - \beta = k\pi$ ,  $k \in Z$  bo'lsa,  $\operatorname{tg} \alpha = \operatorname{tg} \beta$ .

Keltirilgan teoremalardan foydalanib yechiladigan tenglamalardan na'munalar keltiramiz.

9-misol.  $\sin 2x = \sin 5x$  tenglamani yeching.

Yechilishi. 1-teoremaga ko'ra ikki burchak sinuslarining teng bo'lishi shartlarini yozamiz.

$$1) 5x - 2x = 2k\pi \Leftrightarrow 3x = 2k\pi \Rightarrow x = \frac{2k\pi}{3}, k \in Z:$$

$$2) 5x + 2x = (2k + 1)\pi \Leftrightarrow 7x = 2k\pi + \pi \Rightarrow x = \frac{\pi}{7} + \frac{2k\pi}{7}, k \in Z.$$

$$\text{Javob: } \frac{2k\pi}{7}; \frac{\pi}{7} + \frac{2k\pi}{7}, k \in Z.$$

10-misol.  $\sin 5x = \cos 7x - \cos \frac{3\pi}{2}$  tenglamani yeching.

$$\text{Yechilishi. } \sin 5x = \cos 7x - 0 \Leftrightarrow \cos\left(\frac{\pi}{2} - 5x\right) = \cos 7x.$$

Ikki burchak kosinuslarining tenglik shartlaridan foydalanamiz:

$$1) 7x - \frac{\pi}{2} + 5x = 2k\pi \Leftrightarrow 12x = \frac{\pi}{2} + 2k\pi \Rightarrow x = \frac{\pi}{24} + \frac{k\pi}{6}, k \in Z.$$

$$2) 7x + \frac{\pi}{2} - 5x = 2k\pi \Leftrightarrow 2x = -\frac{\pi}{2} + 2k\pi \Rightarrow x = -\frac{\pi}{4} + k\pi, k \in Z.$$

$$\text{Javob: } -\frac{\pi}{24} + \frac{k\pi}{6}; -\frac{\pi}{4} + k\pi, k \in Z.$$

11-misol.  $\text{tg}(x + 1) \text{ctg}(2x + 3) = 1$  tenglamani yeching.

Yechilishi.  $\text{tg}(2x + 3) \neq 0$  bo'lganligidan berilgan tenglamani

$$\text{tg}(x + 1) \cdot \frac{1}{\text{tg}(2x + 3)} = 1 \Leftrightarrow \text{tg}(x + 1) = \text{tg}(2x + 3)$$

ko'rinishga keltirib, ikki burchak tangenslari tengligi shartidan foydalanamiz:

$$2x + 3 - x - 1 = k\pi \Rightarrow x = k\pi - 2, k \in Z.$$

$x$  ning bu to'plamdagi har qanday qiymatida ham  $\text{tg}(x + 1)$  va  $\text{tg}(2x + 3)$  aniqlangan.

$$\text{Javob: } k\pi - 2, k \in Z.$$

**2.5.  $a \sin x + b \cos x = c$  shaklidagi tenglamalar.** Bu yerda  $a, b, c \in R$  tenglama koeffitsiyentlari. Agar  $a = b = 0, c \neq 0$  bo'lsa, tenglama ma'noga ega bo'lmaydi.

$a \sin x + b \cos x = c$  shaklidagi tenglamalarni yechishning bir necha usullari mavjud. Ulardan ayrimlarini keltirib o'tamiz.

a) **Yordamchi burchak kiritish usuli.**

Ma'lumki, agar  $a^2 + b^2 = 1$  bo'lsa, u holda shunday  $\varphi$  burchak mavjudki,  $a = \cos \varphi, b = \sin \varphi$  va aksincha. Shunga ko'ra

$$a \sin x + b \cos x = c \Leftrightarrow \sqrt{a^2 + b^2} \left( \frac{a}{\sqrt{a^2 + b^2}} \sin x + \frac{b}{\sqrt{a^2 + b^2}} \cos x \right) = c;$$

$$\left[ \frac{a}{\sqrt{a^2+b^2}} = \cos \varphi; \frac{b}{\sqrt{a^2+b^2}} = \sin \varphi \right] \Leftrightarrow \sqrt{a^2+b^2} (\cos \varphi \sin x + \sin \varphi \cos x) = c \Leftrightarrow \sin(x+\varphi) = \frac{c}{\sqrt{a^2+b^2}}.$$

Hosil bo'lgan tenglama  $a^2 + b^2 \geq c^2$  bo'lsagina yechimga ega:

$$x = (-1)^k \arcsin \frac{c}{\sqrt{a^2+b^2}} + k\pi - \varphi, \quad k \in Z. \quad \text{Bunda } \varphi = \arctg \frac{b}{a}.$$

b) **Ratsionallashtirish usuli.** Bu usulga ko'ra  $x \neq \pi + 2k\pi$  da

$$\sin x = \frac{2\operatorname{tg} \frac{x}{2}}{1+\operatorname{tg}^2 \frac{x}{2}}, \quad \cos x = \frac{1-\operatorname{tg}^2 \frac{x}{2}}{1+\operatorname{tg}^2 \frac{x}{2}}, \quad \operatorname{tg} x = \frac{2\operatorname{tg} \frac{x}{2}}{1-\operatorname{tg}^2 \frac{x}{2}}$$

tengliklar o'rinli ekanligidan  $a \sin x + b \cos x = c$  tenglama  $\operatorname{tg} \frac{x}{2} = t$  belgilash yordamida

$$(b+c)t^2 - 2at + (c-b) = 0$$

tenglamaga keltiriladi. Agar  $b+c \neq 0$  bo'lib,  $a^2 + b^2 \geq c^2$  bo'lsa,  $t$  ning qiymatlari haqiqiy bo'ladi:

$$t_{1,2} = \frac{a \pm \sqrt{a^2 + b^2 - c^2}}{b+c};$$

1) Agar  $a^2 + b^2 < c^2$  bo'lsa, tenglama yechimga ega bo'lmaydi.

2) Agar  $a^2 + b^2 \geq c^2$  bo'lib,  $c \neq -b$  bo'lsa,

$$x = 2\arctg \frac{a \pm \sqrt{a^2 + b^2 - c^2}}{b+c} + 2k\pi, \quad k \in Z.$$

3) Agar  $c = -b$  bo'lsa, tenglama  $x = \pi + 2k\pi$  va  $x = -2\arctg \frac{b}{a} + 2k\pi, \quad k \in Z$  yechimlarga ega bo'ladi.

d) **Yarim burchaklarga o'tish yo'li bilan bir jinsli tenglamaga keltirish usuli.**

Bu usulga ko'ra  $a \sin x + b \cos x = c$  tenglama quyidagi ko'rinishga keltiriladi:

$$2a \sin \frac{x}{2} \cos \frac{x}{2} + b (\cos^2 \frac{x}{2} - \sin^2 \frac{x}{2}) = c (\sin^2 \frac{x}{2} + \cos^2 \frac{x}{2}) \Leftrightarrow$$

$$\Leftrightarrow (c+b) \sin^2 \frac{x}{2} - 2a \sin \frac{x}{2} \cos \frac{x}{2} + (c-b) \cos^2 \frac{x}{2} = 0.$$

Bunday bir jinsli tenglamalarning yechilishi oldingi badda bayon qilinganidek amalga oshiriladi.

12-misol.  $5 \sin x - 4 \cos x = 4$  tenglamani yeching.

Yechilishi. Berilgan tenglamada  $a = 5$ ,  $b = -4$ ,  $c = 4$ , bo'lib,  $c = -b$ . Ratsionallashtirish usulidan foydalanamiz:

$$\frac{10t - 4(1-t^2)}{1+t^2} = 4 \Leftrightarrow 10t - 4 + 4t^2 = 4 + 4t^2 \Leftrightarrow 10t = 8 \Rightarrow$$

$$\Rightarrow \left[ t = \frac{4}{5} \right] \Rightarrow \operatorname{tg} x = \frac{4}{5} \Rightarrow [x = 2\operatorname{arctg} 0,8 + 2k\pi, k \in \mathbb{Z}.$$

$c = -b$  bo'lganligi uchun  $x = \pi + 2k\pi$ ,  $k \in \mathbb{Z}$  shaklidagi yechimlar to'plami ham mavjud.

Berilgan tenglamada quyidagi almashtirishlarni bajarish mumkin:

$$5 \sin x - 4 \cos x = 4 \Leftrightarrow 5 \sin x = 4(1 + \cos x) \Leftrightarrow 10 \sin \frac{x}{2} \cos \frac{x}{2} =$$

$$= 8 \cos^2 \frac{x}{2} \Leftrightarrow 2 \cos \frac{x}{2} \left( 5 \sin \frac{x}{2} - 4 \cos \frac{x}{2} \right) = 0 \Leftrightarrow$$

$$\Leftrightarrow \begin{cases} 2 \cos \frac{x}{2} = 0, & (a) \\ 5 \sin \frac{x}{2} - 4 \cos \frac{x}{2} = 0 & (b) \end{cases}$$

a) tenglamaning yechimi  $x = \pi + 2k\pi$ ,  $k \in \mathbb{Z}$ ;

b) tenglama yechimi  $x = 2\operatorname{arctg} 0,8 + 2k\pi$ ,  $k \in \mathbb{Z}$ .

Javob:  $2\operatorname{arctg} 0,8 + 2k\pi$ ,  $\pi + 2k\pi$ ,  $k \in \mathbb{Z}$ .

### 3-§. Teskari trigonometrik funksiyalar qatnashgan tenglamalar

Teskari trigonometrik funksiyalar qatnashgan tenglamalarni yechishda arksinus, arkkosinus, arktangenslarning ta'riflaridan va XII bob, 8.8-bandda keltirilgan ayniyatlardan foydalaniladi.

1-misol.  $\arcsin^2 x - \frac{\pi}{2} \arcsin x + \frac{\pi^2}{18} = 0$  tenglamani yeching.

Yechilishi. Qulaylik uchun  $\arcsin x = t$  ( $-\frac{\pi}{2} \leq t \leq \frac{\pi}{2}$ ) belgilash kiritamiz. U holda

$$t^2 - \frac{\pi}{2} t + \frac{\pi^2}{18} = 0 \Rightarrow \begin{cases} t_1 = \frac{\pi}{6}, \\ t_2 = \frac{\pi}{3}. \end{cases}$$

$$\text{Bundan, } \arcsin x = \frac{\pi}{6} \Rightarrow x_1 = \frac{1}{2},$$

$$\arcsin x = \frac{\pi}{3} \Rightarrow x_2 = \frac{\sqrt{3}}{2}.$$

$$\text{Javob: } \frac{1}{2}; \frac{\sqrt{3}}{2}.$$

2-misol.  $6 \arcsin(x^2 - 6x + 8,5) = \pi$  tenglamani yeching.

$$\text{Yechilishi. } 6 \arcsin(x^2 - 6x + 8,5) = \pi \Leftrightarrow \arcsin(x^2 - 6x + 8,5) = \frac{\pi}{6} \Leftrightarrow x^2 - 6x + 8,5 = 0,5 \Leftrightarrow x^2 - 6x + 8 = 0 \Rightarrow \begin{cases} x_1 = 2, \\ x_2 = 4. \end{cases}$$

Javob: 2; 4.

3-misol.  $\arcsin \frac{2}{3\sqrt{x}} - \arcsin \sqrt{1-x} = \arcsin \frac{1}{3}$  tenglamani yeching.

Yechilishi. Tenglama  $0 < x \leq 1$  oraliqda aniqlangan.

$$\arcsin \frac{2}{3\sqrt{x}} = \alpha \left( -\frac{\pi}{2} \leq \alpha \leq \frac{\pi}{2} \right), \quad \arcsin \sqrt{1-x} = \beta \left( -\frac{\pi}{2} \leq \beta \leq \frac{\pi}{2} \right)$$

belgilashlar kiritamiz. U holda

$$\sin \alpha = \frac{2}{3\sqrt{x}} \quad (a), \quad \sin \beta = \sqrt{1-x} \quad (b)$$

$$\cos^2 \alpha = 1 - \sin^2 \alpha = 1 - \frac{4}{9x} = \frac{9x-4}{9x}; \quad \cos \alpha > 0.$$

$$\cos \alpha = \frac{1}{3} \sqrt{\frac{9x-4}{x}}, \quad (d)$$

$$\cos \beta = \sqrt{1-1+x} = \sqrt{x}. \quad (e)$$

Qabul qilingan belgilashlar va (a), (b), (d), (e) munosabatlarni inobatga olib, berilgan tenglamaning ildizini topamiz:

$$\begin{aligned} \arcsin \frac{2}{3\sqrt{x}} - \arcsin \sqrt{1-x} &= \arcsin \frac{1}{3} \Rightarrow \alpha - \beta = \arcsin \frac{1}{3} \Leftrightarrow \\ \Leftrightarrow \sin(\alpha - \beta) &= \sin\left(\arcsin \frac{1}{3}\right) \Leftrightarrow \sin \alpha \cos \beta - \cos \alpha \sin \beta = \frac{1}{3} \Rightarrow \\ \Rightarrow \frac{2}{3\sqrt{x}} \cdot \sqrt{x} - \frac{1}{3} \sqrt{\frac{9x-4}{x}} \cdot \sqrt{1-x} &= \frac{1}{3} \Leftrightarrow \sqrt{\frac{9x-4}{x}} \cdot \sqrt{1-x} = 1 \Leftrightarrow \\ \Leftrightarrow 9x^2 - 12x + 4 = 0 \Leftrightarrow (3x-2)^2 = 0 \Leftrightarrow 3x-2 = 0 \Rightarrow [x = \frac{2}{3}. \end{aligned}$$

$$\text{Javob: } \frac{2}{3}.$$

#### 4-§. Trigonometrik tengsizliklar

«>» yoki «<» tengsizlik belgilari bilan berilgan trigonometrik ifodalar **trigonometrik tengsizliklar** deyiladi. Trigonometrik tengsizliklarni yechish — bu tengsizlikdagi noma'lumlarning tengsizlikni qanoatlantiruvchi barcha qiymatlarini topish demakdir. Trigonometrik tengsizliklarni yechishda trigonometrik funksiyalarning monotonlik xossalaridan va davriyligidan foydalaniladi.

$\sin x > a$ ,  $\sin x < a$ ,  $\cos x > a$ ,  $\cos x < a$ ,  $\operatorname{tg} x > a$ ,  $\operatorname{tg} x < a$ ,  $\sin x \geq a$ ,  $\operatorname{tg} x \geq a$ , kabi tengsizliklar **eng sodda trigonometrik tengsizliklar** deyiladi. Faqat  $\sin x$  yoki  $\cos x$  qatnashgan tengsizliklarni yechish uchun bunday tengsizlikni uzunligi  $2\pi$  bo'lgan biror oraliqda yechish yetarlidir. Barcha yechimlar to'plami kesmada topilgan yechimga  $2k\pi$ ,  $k \in \mathbb{Z}$  sonni qo'shib qo'yish yo'li bilan topiladi. Trigonometrik tengsizliklarni yechishda  $y = \sin x$ ,  $y = \cos x$ ,  $y = \operatorname{tg} x$ , va  $y = \operatorname{ctg} x$  funksiyalarining grafiklaridan yoki birlik aylanadan foydalaniladi.

**4.1.  $\sin x > a$ ,  $\sin x < a$  tengsizliklarni yechish.**  $|\sin x| \leq 1$  bo'lganligi sababli quyidagi tasdiqlar o'rinlidir.

Agar:

$a \leq -1$  bo'lsa,  $\sin x < a$ ;  $a > 1$  bo'lsa,  $\sin x \geq a$ ;

$a < -1$  bo'lsa,  $\sin x \leq a$ ;  $a \geq 1$  bo'lsa,  $\sin x > a$  tengsizliklar yechimga ega emas.

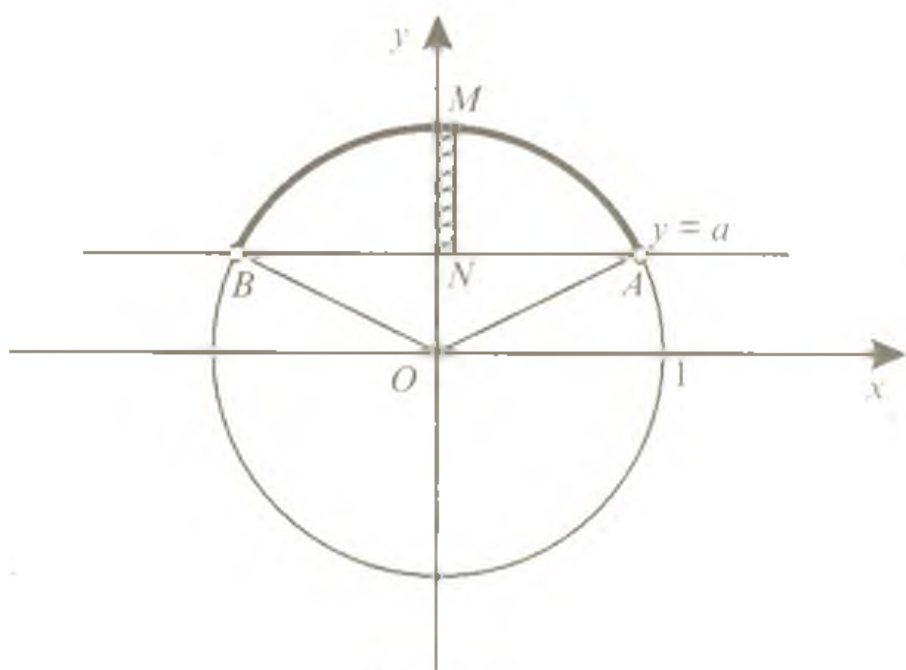

137-rasm



Agar

$a > 1$  bo'lsa,  $\sin x < a$ ;  $a \leq -1$  bo'lsa,  $\sin x \geq a$ ;

$a \geq 1$  bo'lsa,  $\sin x \leq a$ ;  $a < -1$  bo'lsa,  $\sin x > a$ ;

tengsizliklar  $x$  ning har qanday qiymatida bajariladi.

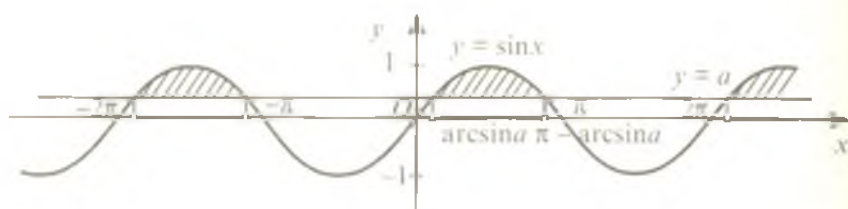

138-rasm

**1.  $\sin x > a$  ( $|a| < 1$ ) tengsizlikning yechilishi.** Birlik aylanada absissalar o'qiga parallel  $y = a$  to'g'ri chiziqni chizamiz. Bu to'g'ri chiziq birlik aylanani  $A$  va  $B$  nuqtalarda kesib o'tadi (137-rasm). Rasmdagi chizmadan ko'rinib turibdiki,  $NM$  oraliqda  $y$  ning barcha qiymatlari  $a$  dan katta; birlik aylana  $AMB$  yoyining barcha nuqtalari  $a$  dan katta ordinataga ega. Shuning uchun  $\sin x > a$  tengsizlikning  $[0; 2\pi]$  kesmadagi yechimlari  $(\arcsin a; \pi - \arcsin a)$  oraliqqa tegishli barcha  $x$  sonlar bo'ladi (138-rasm).  $\sin x$  ning davriyligini hisobga olsak, tengsizlikning butun sonlar o'qidagi yechimlari

$$\arcsin a + 2k\pi < x < \pi - \arcsin a + 2k\pi, k \in \mathbb{Z} \quad (1)$$

shaklda yoziladi.

Bundan buyon eng sodda trigonometrik tengsizliklarning yechimlarini topishga doir misollarda tengsizlik yechimlarini tasvirlovchi chizmalarni sharhlarsiz keltiramiz. O'quvchilarga ularni mustaqil tahlil qilish tavsiya qilinadi.

$\sin x > 0$  tengsizlikning yechimlar to'plami  $2k\pi < x < \pi + 2k\pi$ ,  $k \in \mathbb{Z}$ .

$\sin x < 0$  tengsizlikning yechimlar to'plami  $2k\pi - \pi < x < 2k\pi$ ,  $k \in \mathbb{Z}$  ekanligini yodda tuting.

1-misol.  $\sin x > \frac{\sqrt{3}}{2}$  tengsizlikni yeching.

**Yechilishi.** (1) formuladan foydalanib, berilgan tengsizlikning yechimlar to'plamini aniqlaymiz:

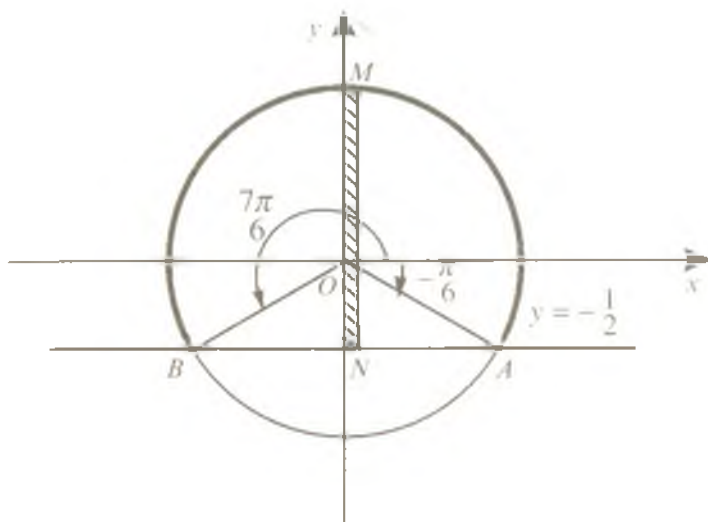

139-rasm

$$\arcsin \frac{\sqrt{3}}{2} + 2k\pi < x < \pi - \arcsin \frac{\sqrt{3}}{2} + 2k\pi \Leftrightarrow \frac{\pi}{3} + 2k\pi < x < \pi - \frac{\pi}{3} + 2k\pi \Rightarrow \frac{\pi}{3} + 2k\pi < x < \frac{2\pi}{3} + 2k\pi, k \in \mathbb{Z}.$$

Javob:  $\left(\frac{\pi}{3} + 2k\pi; \frac{2\pi}{3} + 2k\pi\right), k \in \mathbb{Z}.$

2-misol.  $\sin x \geq -\frac{1}{2}$  tengsizlikni yeching.

Yechilishi. (1) formuladan foydalanamiz. Unga ko'ra

$$\arcsin\left(-\frac{1}{2}\right) + 2k\pi \leq x \leq \pi - \arcsin\left(-\frac{1}{2}\right) + 2k\pi \Leftrightarrow -\arcsin \frac{1}{2} + 2k\pi \leq x \leq \pi + \arcsin \frac{1}{2} + 2k\pi \Leftrightarrow -\frac{\pi}{6} + 2k\pi \leq x \leq \pi + \frac{\pi}{6} + 2k\pi \Rightarrow -\frac{\pi}{6} + 2k\pi \leq x \leq \frac{7\pi}{6} + 2k\pi, k \in \mathbb{Z}.$$

Tengsizlikning yechimi 139-rasmda tasvirlangan.

Javob:  $\left[-\frac{\pi}{6} + 2k\pi; \frac{7\pi}{6} + 2k\pi, k \in \mathbb{Z}\right].$

**2.  $\sin x < a$  ( $|a| < 1$ ) tengsizlikning yechilishi.** 140, 141-rasmlardan ko'rinib turibdiki, tengsizlikning  $[-\pi; \pi]$  kesmadagi yechimi  $x$  ning  $(-\pi - \arcsin a; \arcsin a)$  oraliqdagi qiymatlaridan, butun sonlar o'qida esa  $(2k\pi - \pi - \arcsin a; 2k\pi + \arcsin a)$ ,  $k \in \mathbb{Z}$  oraliqdagi qiymatlar to'plamidan iborat.

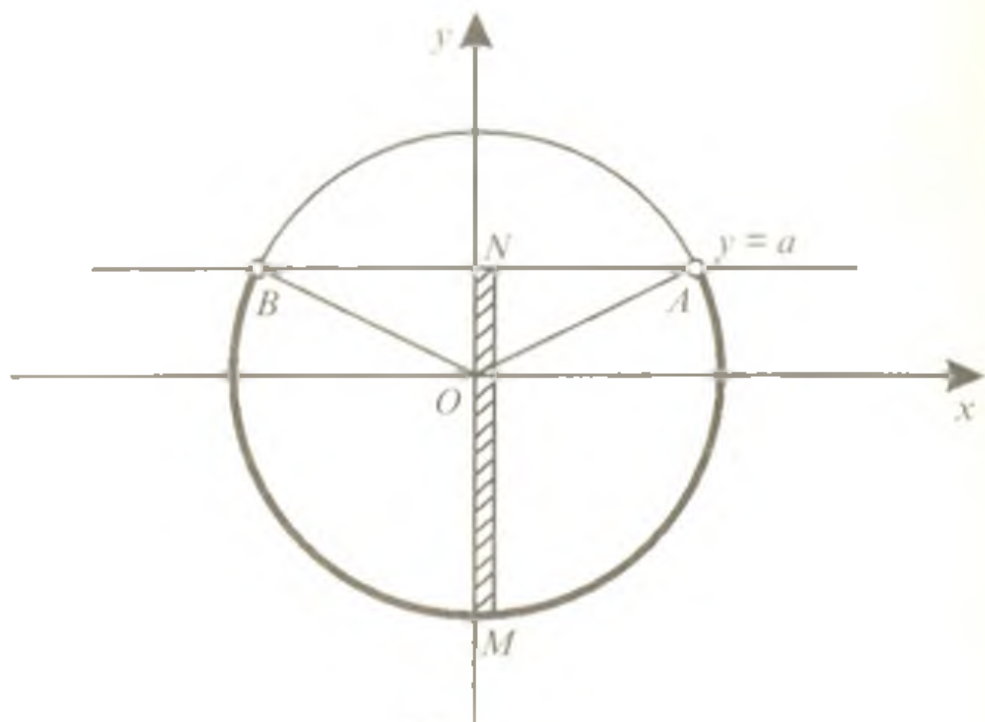

140-rasm

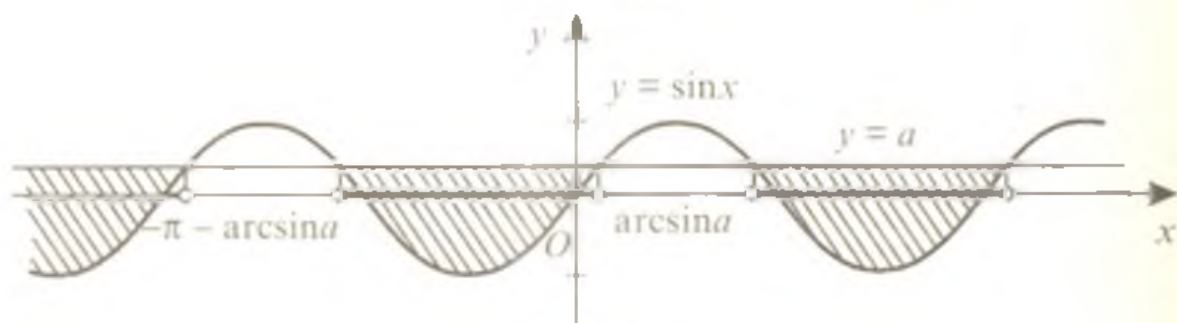

141-rasm

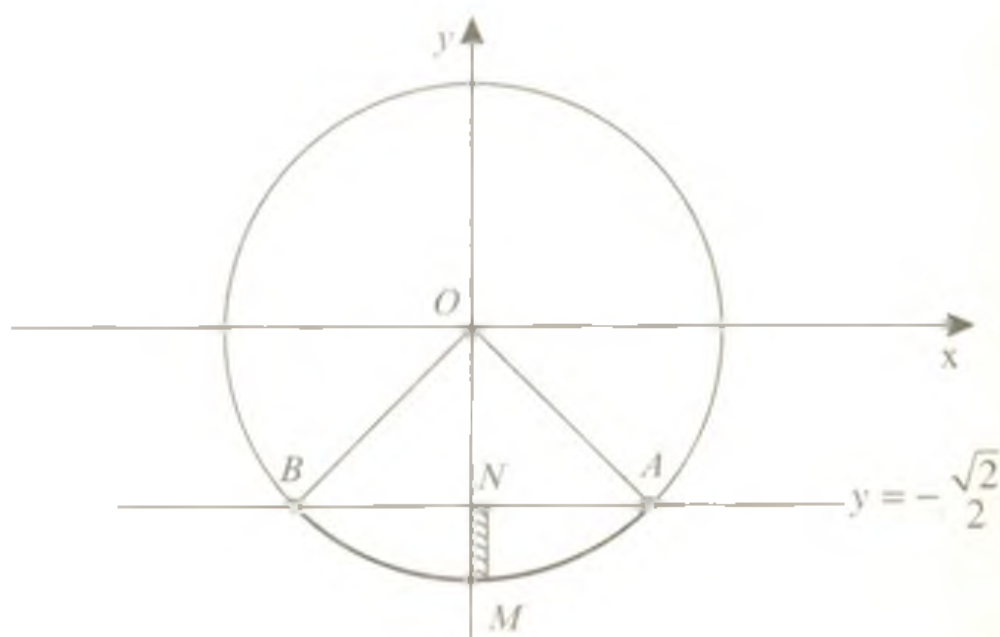

142-rasm

Shunday qilib,  $\sin x < a$  tengsizlikning yechimlar to'plami

$$2k\pi - \pi - \arcsin a < x < 2k\pi + \arcsin a, k \in Z \quad (2)$$

formula bilan ifodalanadi.

3-misol.  $\sin 2x < -\frac{\sqrt{2}}{2}$  tengsizlikni yeching.

Yechilishi. 142-rasmdagi chizmadan ko'rinib turibdiki,

$$2k\pi - \frac{3\pi}{4} < 2x < 2k\pi - \frac{\pi}{4}. \text{ Bundan } k\pi - \frac{3\pi}{8} < x < k\pi - \frac{\pi}{8}, k \in Z.$$

$$\text{Javob: } \left(k\pi - \frac{3\pi}{8}; -\frac{\pi}{8} + k\pi\right), k \in Z.$$

4-misol.  $2\cos^2 x + \sin x > 2$  tengsizlikni yeching.

Yechilishi.  $2\cos^2 x + \sin x > 2 \Leftrightarrow 2(1 - \sin^2 x) + \sin x > 2 \Leftrightarrow 2\sin^2 x - \sin x < 0 \Leftrightarrow \sin x (2\sin x - 1) < 0$ . Berilgan tengsizlikka teng kuchli bo'lgan bu tengsizlikda  $\sin x = y$  belgilash orqali yangi o'zgaruvchi kiritamiz va

$$y(2y - 1) < 0$$

algebraik tengsizlikni hosil qilamiz. Bu tengsizlikning yechimi

$$0 < y < \frac{1}{2}.$$

Shunday qilib,  $0 < \sin x < \frac{1}{2}$ . Bu tengsizlikning yechimlar to'plami  $2k\pi < x < \frac{\pi}{6} + 2k\pi, k \in Z$  yoki  $\frac{5\pi}{6} + 2k\pi < x < \pi + 2k\pi, k \in Z$  oraliqlardan iborat (143-rasm).

$$\text{Javob: } \left(2k\pi; \frac{\pi}{6} + 2k\pi\right) \cup \left(\frac{5\pi}{6} + 2k\pi; \pi + 2k\pi\right), k \in Z.$$

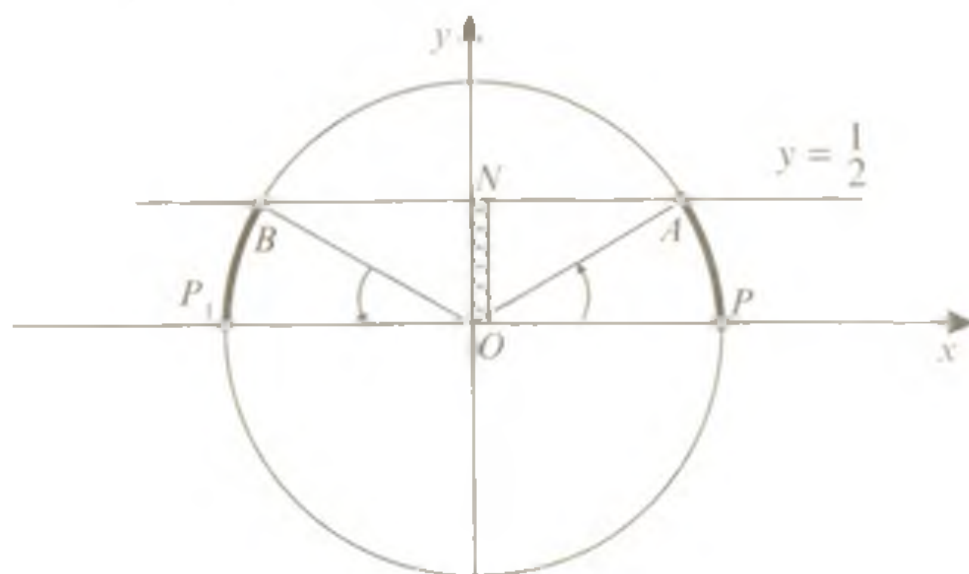

143-rasm

**4.2.  $\cos x > a$ ,  $\cos x < a$  tengsizliklarni yechish.**  $|\cos x| \leq 1$  bo'lganligi sababli quyidagi tasdiqlar o'rinli.

Agar:

$a \leq -1$  bo'lsa,  $\cos x < a$ ;  $a > 1$  bo'lsa,  $\cos x \geq a$ ;

$a < -1$  bo'lsa,  $\cos x \leq a$ ;  $a \geq 1$  bo'lsa,  $\cos x > a$

tengsizliklar yechimga ega emas.

Agar:

$a > 1$  bo'lsa,  $\cos x < a$ ;  $a \leq -1$  bo'lsa,  $\cos x \geq a$ ;

$a \geq 1$  bo'lsa,  $\cos x \leq a$ ;  $a < -1$  bo'lsa,  $\cos x > a$

tengsizliklar  $x$  ning har qanday qiymatlarida bajariladi.

**1.  $\cos x > a$  ( $|a| < 1$ ) tengsizlikning yechilishi**

Birlik aylanada ordinatalar o'qiga parallel  $x = a$  to'g'ri chiziqni chizamiz. Bu to'g'ri chiziq birlik aylanani  $A$  va  $B$  nuqtalarda kesib o'tadi (144-rasm).  $A$  va  $B$  nuqtalarning absissalari  $a$  ga teng bo'lib.  $NP$  oraliqda  $x$  ning barcha qiymatlari  $a$  dan katta; birlik aylana  $BPA$  yoyining barcha nuqtalari  $a$  dan katta absissaga ega. Shuning uchun  $\cos x > a$  tengsizlikning  $[-\pi; \pi]$  kesmadagi yechimlari  $(-\arccos a; \arccos a)$  oraliqqa tegishli barcha  $x$  sonlar bo'ladi (145-rasm).  $\cos x$  ning davriyligini hisobga olib tengsizlikning butun sonlar o'qidagi yechimlar to'plamini

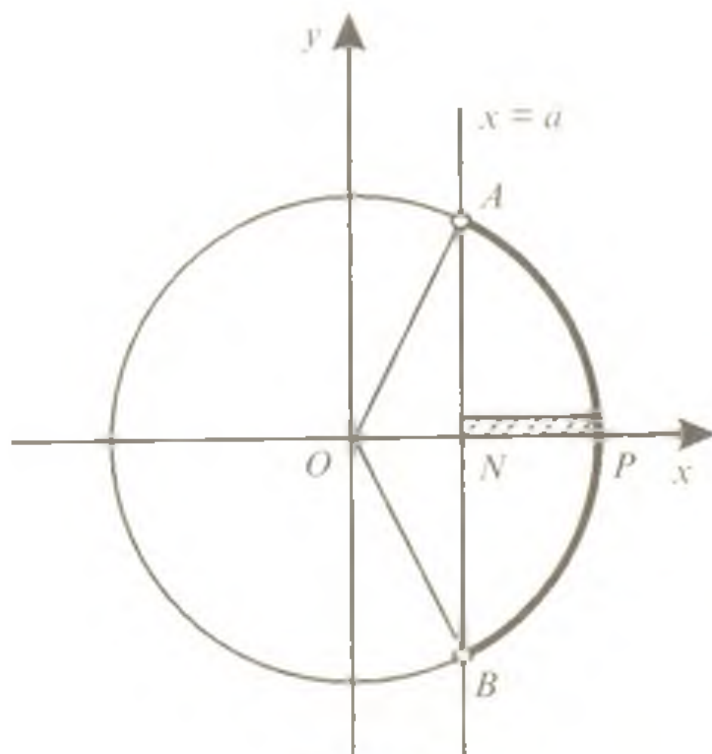

144-rasm

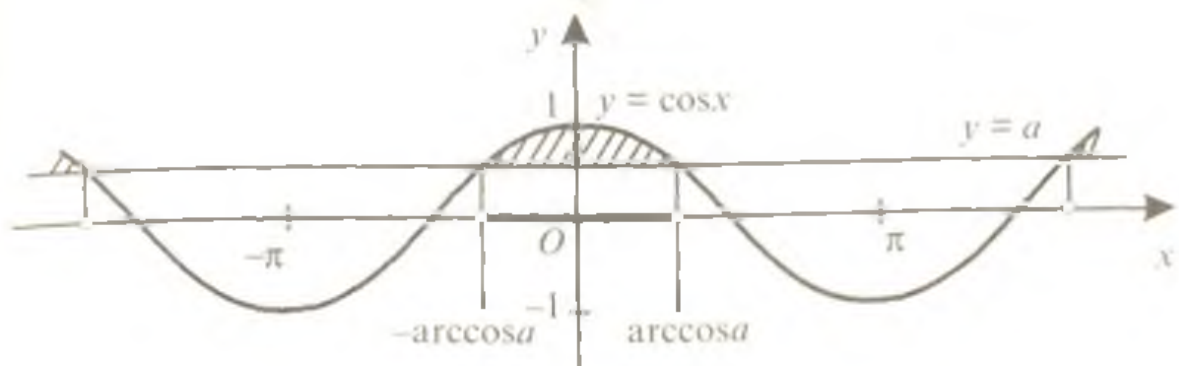

145-rasm

$$2k\pi - \arccos a < x < 2k\pi + \arccos a, k \in \mathbb{Z} \quad (3)$$

formula bilan berilishi mumkin.

$\cos x > 0$  tengsizlikning yechimlar to'plami

$$2k\pi - \frac{\pi}{2} < x < \frac{\pi}{2} + 2k\pi, k \in \mathbb{Z}.$$

$\cos x < 0$  tengsizlikning yechimlar to'plami

$$2k\pi + \frac{\pi}{2} < x < \frac{3\pi}{2} + 2k\pi, k \in \mathbb{Z} \text{ ekanligini yodda tuting.}$$

5-misol.  $\cos x > -\frac{1}{2}$  tengsizlikni yeching.

Yechilishi. Berilgan tengsizlikni (3) formuladan foydalanib yechamiz:

$$2k\pi - \arccos\left(-\frac{1}{2}\right) < x < 2k\pi + \arccos\left(-\frac{1}{2}\right) \Leftrightarrow 2k\pi - \left(\pi - \frac{\pi}{3}\right) < x < 2k\pi + \left(\pi - \frac{\pi}{3}\right) \Leftrightarrow 2k\pi - \frac{2\pi}{3} < x < 2k\pi + \frac{2\pi}{3}, k \in \mathbb{Z}.$$

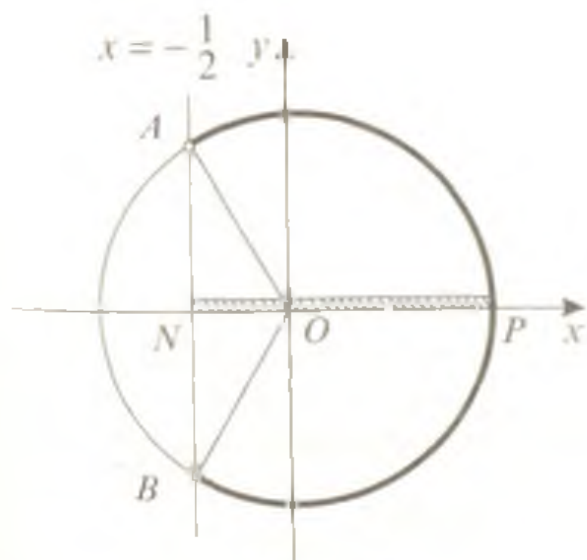

146-rasm

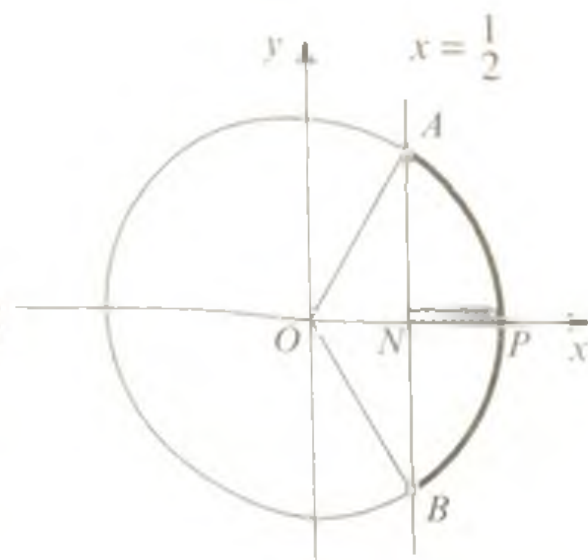

147-rasm

Tengsizlikning yechimi 146-rasmda tasvirlangan.

Javob:  $\left(2k\pi - \frac{2\pi}{3}; 2k\pi + \frac{2\pi}{3}\right), k \in Z.$

6-misol.  $2\cos^2 x - 9\cos x + 4 < 0$  tengsizlikni yeching.

Yechilishi.  $\cos x = y$  belgilash kiritamiz. U holda

$$2y^2 - 9y + 4 < 0 \Leftrightarrow 2\left(y - \frac{1}{2}\right)(y - 4) < 0 \Rightarrow \frac{1}{2} < y < 4.$$

$|\cos x| \leq 1$  bo'lganligi uchun  $\frac{1}{2} < \cos x \leq 1$  tengsizlikka ega bo'lamiz. Uning yechimlar to'plami  $2k\pi - \frac{\pi}{3} < x < \frac{\pi}{3} + 2k\pi, k \in Z$  (147-rasm).

Javob:  $\left(2k\pi - \frac{\pi}{3}; 2k\pi + \frac{\pi}{3}\right), k \in Z.$

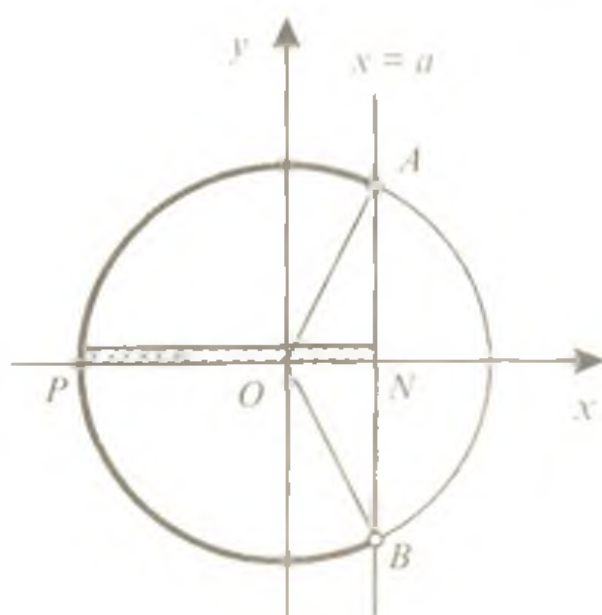

148-rasm

**2.  $\cos x < a$  ( $|a| < 1$ ) tengsizlikning yechilishi.** 148, 149-rasmlardan ko'rinib turibdiki, tengsizlikning  $[0; 2\pi]$  kesmadagi yechimi  $x$  ning ( $\arccos a; 2\pi - \arccos a$ ) oraliqdagi qiymatlaridan iborat.  $\cos x$  ning davriyligini hisobga olib tengsizlikning butun sonlar o'qidagi yechimlari to'plamini yozamiz:

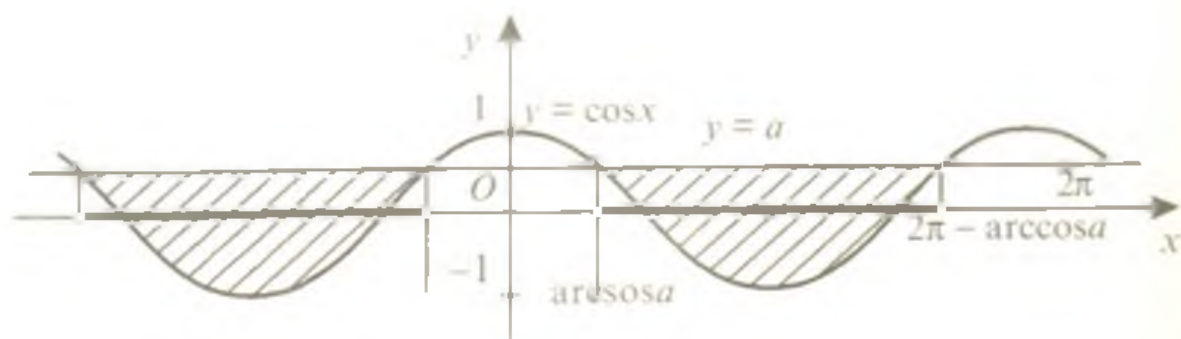

149-rasm

$$2k\pi + \arccos a < x < 2k\pi + 2\pi - \arccos a, k \in Z \quad (4)$$

7-misol.  $\cos 2x < -\frac{1}{2}$   
tengsizlikni yeching.

Yechilishi.  $2x$  ni  $\alpha$  deb belgilasak, berilgan tengsizlik  $\cos \alpha < -\frac{1}{2}$  ko'rinishni oladi. Bu tengsizlikni birlik aylananing absissasi  $-\frac{1}{2}$  dan kichik bo'lgan barcha nuqtalari qanoatlantiradi (150-rasm), shuning uchun  $\cos \alpha < -\frac{1}{2}$  tengsizlikning  $[0; 2\pi]$  kesmadagi yechimi

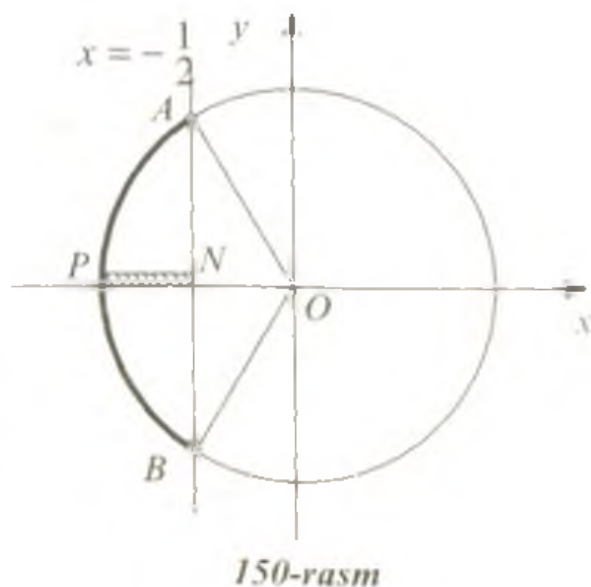

$$\begin{aligned} \arccos\left(-\frac{1}{2}\right) < \alpha < 2\pi - \arccos\left(-\frac{1}{2}\right) &\Rightarrow \pi - \arccos \frac{1}{2} < \alpha < \\ < 2\pi - \left(\pi - \arccos \frac{1}{2}\right) &\Rightarrow \pi - \frac{\pi}{3} < \alpha < 2\pi - \left(\pi - \frac{\pi}{3}\right) \Rightarrow \frac{2\pi}{3} < \alpha < \frac{4\pi}{3} \end{aligned}$$

kabi topiladi.  $\cos \alpha$  ni davriyligini hisobga olsak,  $2k\pi + \frac{2\pi}{3} < \alpha < 2k\pi + \frac{4\pi}{3}$ ,  $k \in Z$ .

Endi  $x$  o'zgaruvchiga o'tib, berilgan tengsizlik yechimini yozamiz:

$$2k\pi + \frac{2\pi}{3} < 2x < 2k\pi + \frac{4\pi}{3} \Leftrightarrow k\pi + \frac{\pi}{3} < x < k\pi + \frac{2\pi}{3}, k \in Z.$$

Javob:  $\left(k\pi + \frac{\pi}{3}; k\pi + \frac{2\pi}{3}\right)$ ,  $k \in Z$ .

8-misol.  $7\cos^2 x - 5\cos x + \sin^2 x \leq 0$  tengsizlikni yeching.

Yechilishi.

$$\begin{aligned} 7\cos^2 x - 5\cos x + \sin^2 x \leq 0 &\Leftrightarrow 7\cos^2 x - 5\cos x + 1 - \cos^2 x \leq 0 \Leftrightarrow \\ \Leftrightarrow 6\cos^2 x - 5\cos x + 1 &\leq 0 \end{aligned}$$

Berilgan tengsizlikka teng kuchli bo'lgan bu tengsizlikni yechish uchun  $\cos x = y$  belgilash orqali yangi o'zgaruvchi kiritamiz. U holda

$$6y^2 - 5y + 1 \leq 0 \Leftrightarrow 6\left(y - \frac{1}{3}\right)\left(y - \frac{1}{2}\right) \leq 0 \Rightarrow \frac{1}{3} \leq y \leq \frac{1}{2}.$$

$x$  o'zgaruvchiga o'tib,  $\frac{1}{3} \leq \cos x \leq \frac{1}{2}$  tengsizlikka ega bo'lamiz.



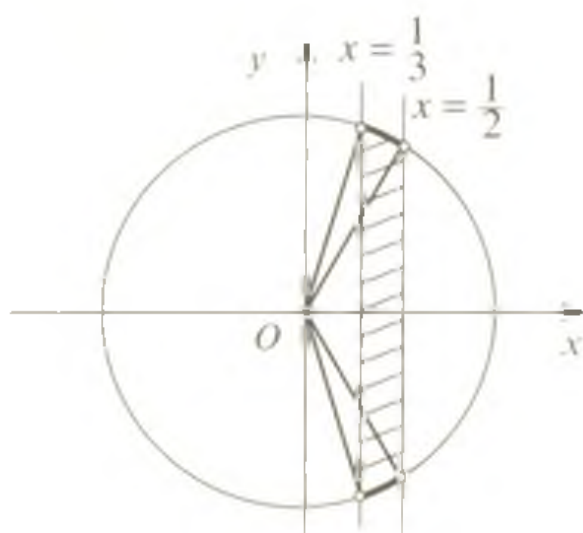

151-rasm

Bu tengsizlikni qanoatlantiruvchi nuqtalar esa  $x = \frac{1}{3}$  to'g'ri chiziqdan o'ngda,  $x = \frac{1}{2}$  to'g'ri chiziqdan chapda yotadi (151-rasm). Birlik aylananing bu qismlariga mos keluvchi burchaklar oraliqlari berilgan tengsizlikning yechimlar to'plamidan iborat. Shunday qilib,

$$2k\pi + \frac{\pi}{3} \leq x \leq 2k\pi + \arccos \frac{1}{3}, k \in Z \text{ va } 2k\pi - \arccos \frac{1}{3} \leq$$

$x \leq 2k\pi - \frac{\pi}{3}, k \in Z$  oraliqlar birlashmasi tengsizlikning yechimi bo'ladi.

Javob:  $\left[2k\pi + \frac{\pi}{3}; 2k\pi + \arccos \frac{1}{3}\right] \cup \left[2k\pi - \arccos \frac{1}{3}; 2k\pi - \frac{\pi}{3}\right], k \in Z.$

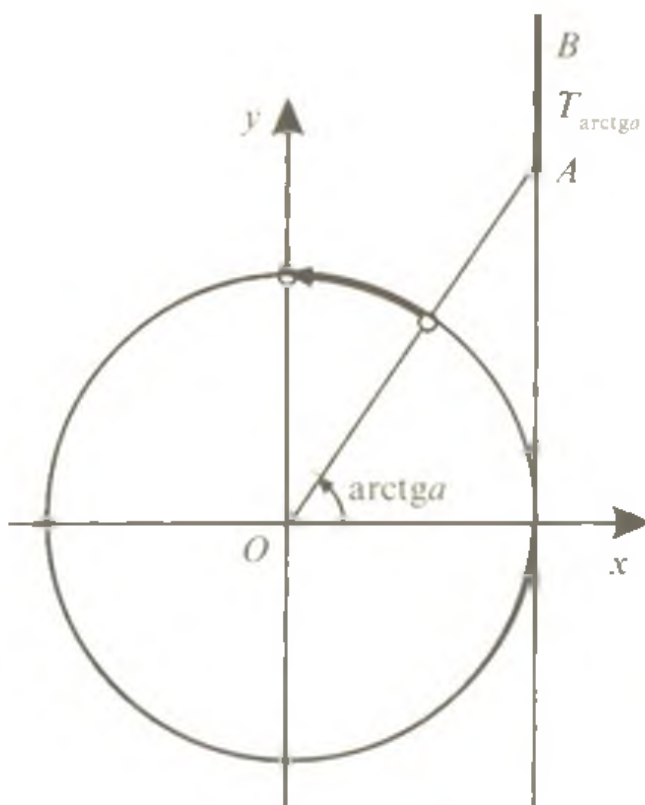

152-rasm

**4.3.  $\operatorname{tg}x > a, \operatorname{tg}x < a$  tengsizliklarni yechish.** Bu tengsizliklar  $a$  ning har qanday qiymatlarida yechimga ega bo'lib, ularni yechishda ham birlik aylanadan yoki  $y = \operatorname{tg}x, y = \operatorname{ctg}x$  funksiyalarning grafiklaridan foydalaniladi.

**1.  $\operatorname{tg}x > a$  ( $a \in R$ ) tengsizlikning yechilishi.** Birlik aylanani chizib, aylanaga  $(1; 0)$  nuqtada urinma bo'lgan  $T_{\arctga}$  — tangenslar chizig'ini chizamiz (152-rasm). Tan-

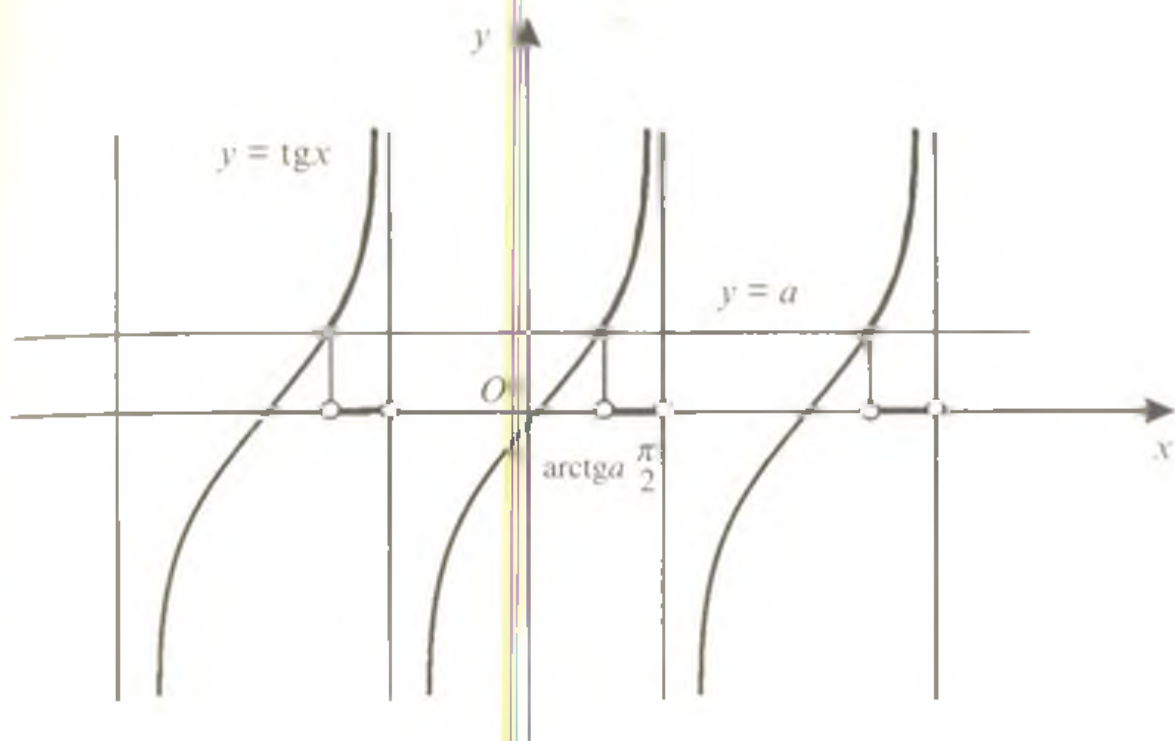

153-rasm

genslar chizig'ida ordinatalari  $a$  dan katta bo'lgan barcha nuqtalar  $AB$  nurda yotibdi. Birlik aylananing bu nurga mos qismi 152-rasmda ajratib ko'rsatilgan. Birlik aylananing bu qismidagi har qanday nuqtada

$$\arctga < x < \frac{\pi}{2}$$

tengsizlik bajariladi. 153-rasmda bu yechim  $y = \text{tg}x$  funksiyaning grafigi orqali tasvirlangan, tengsizlikning butun sonlar o'qidagi yechimlari to'plamini yozamiz:

$$k\pi + \arctga < x < \frac{\pi}{2} + k\pi, \quad k \in \mathbb{Z} \quad (5)$$

9-misol.  $\text{tg}x \geq -1$  tengsizlikni yeching.

Yechilishi. Tengsizlikni yechishda birlik aylanadan foydalanamiz. 154-rasmdan ko'rinib turibdiki, tengsizlik  $-\frac{\pi}{4} \leq x < \frac{\pi}{2}$  oraliqda bajarila-

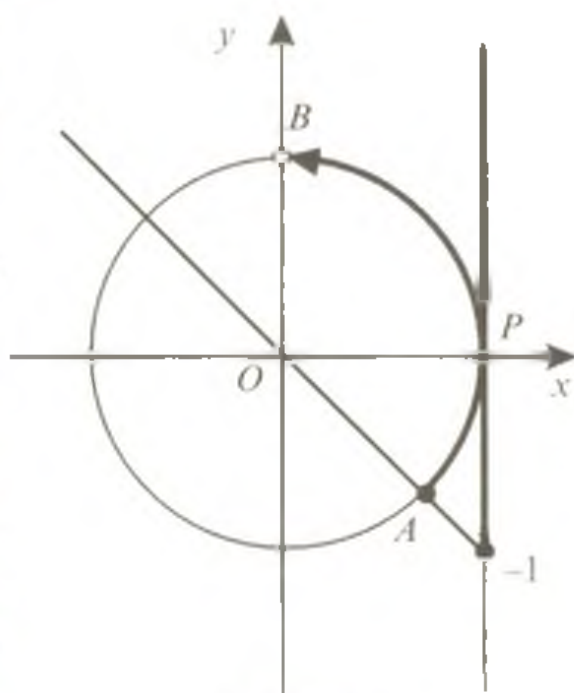

154-rasm

di. ( $\operatorname{tg} x$  funksiya  $x = \frac{\pi}{2}$  da aniqlanmagan). Tengsizlikning davriyligidan foydalanib, butun sonlar o'qi uchun yechimlar to'plamini yozamiz:

$$k\pi - \frac{\pi}{4} \leq x < \frac{\pi}{2} + k\pi, \quad k \in \mathbb{Z}.$$

Javob:  $\left[ k\pi - \frac{\pi}{4}; \frac{\pi}{2} + k\pi \right), \quad k \in \mathbb{Z}.$

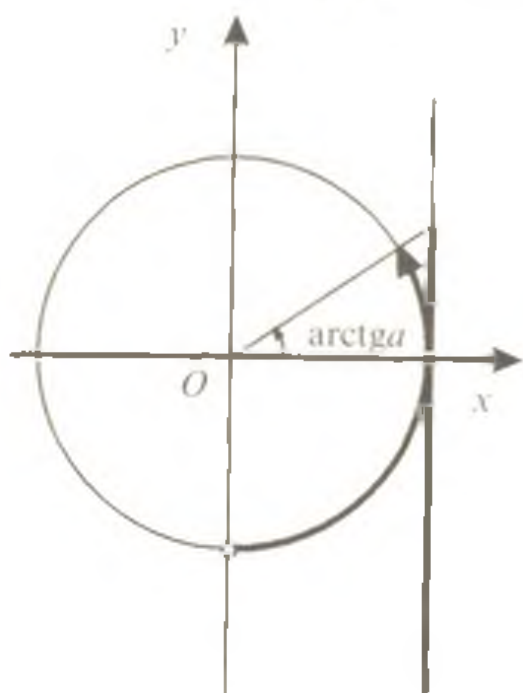

155-rasm

**2.  $\operatorname{tg} x < a$  ( $a \in \mathbb{R}$ ) tengsizlikning yechilishi.** Bu tengsizlik 155-rasmda tasvirlangan birlik aylana va tangenslar chizig'ida ajratib ko'rsatilgan oraliqlarda bajariladi. Shu sababli tangensning davriyligini hisobga olib, tengsizlikning butun sonlar o'qidagi yechimlar to'plami

$$k\pi - \frac{\pi}{2} < x < \operatorname{arctg} a + k\pi, \quad k \in \mathbb{Z} \quad (6)$$

formula bilan ifodalanadi.

$\operatorname{tg} x > 0$  tengsizlikning yechimlar to'plami  $k\pi < x < \frac{\pi}{2} + k\pi, \quad k \in \mathbb{Z},$   
 $\operatorname{tg} x < 0$  tengsizlikning yechimlar to'plami  $k\pi - \frac{\pi}{2} < x < k\pi, \quad k \in \mathbb{Z}$

ekanligini yodda tuting.

10-misol.  $\operatorname{tg}\left(2x - \frac{\pi}{3}\right) \leq \frac{1}{\sqrt{3}}$  tengsizlikni yeching.

Yechilishi. (6) formuladan foydalanamiz:

$$k\pi - \frac{\pi}{2} < 2x - \frac{\pi}{3} \leq \operatorname{arctg} \frac{1}{\sqrt{3}} + k\pi \Leftrightarrow k\pi - \frac{\pi}{2} + \frac{\pi}{3} < 2x \leq \frac{\pi}{6} + \frac{\pi}{3} + k\pi \Leftrightarrow$$

$$\Leftrightarrow k\pi - \frac{\pi}{6} < 2x \leq \frac{\pi}{2} + k\pi \Leftrightarrow \frac{k\pi}{2} - \frac{\pi}{12} < x \leq \frac{\pi}{4} + \frac{k\pi}{2}, \quad k \in \mathbb{Z}.$$

Javob:  $\left( \frac{k\pi}{2} - \frac{\pi}{12}; \frac{\pi}{4} + \frac{k\pi}{2} \right], \quad k \in \mathbb{Z}.$

11-misol.  $4\operatorname{tg}^2 x - \operatorname{tg} x - 3 \geq 0$  ( $x \neq \frac{\pi}{2} + k\pi$ ) tengsizlikni yeching.

Yechilishi.  $\operatorname{tg} x = y$  belgilash orqali yangi o'zgaruvchi kiritamiz. U holda:

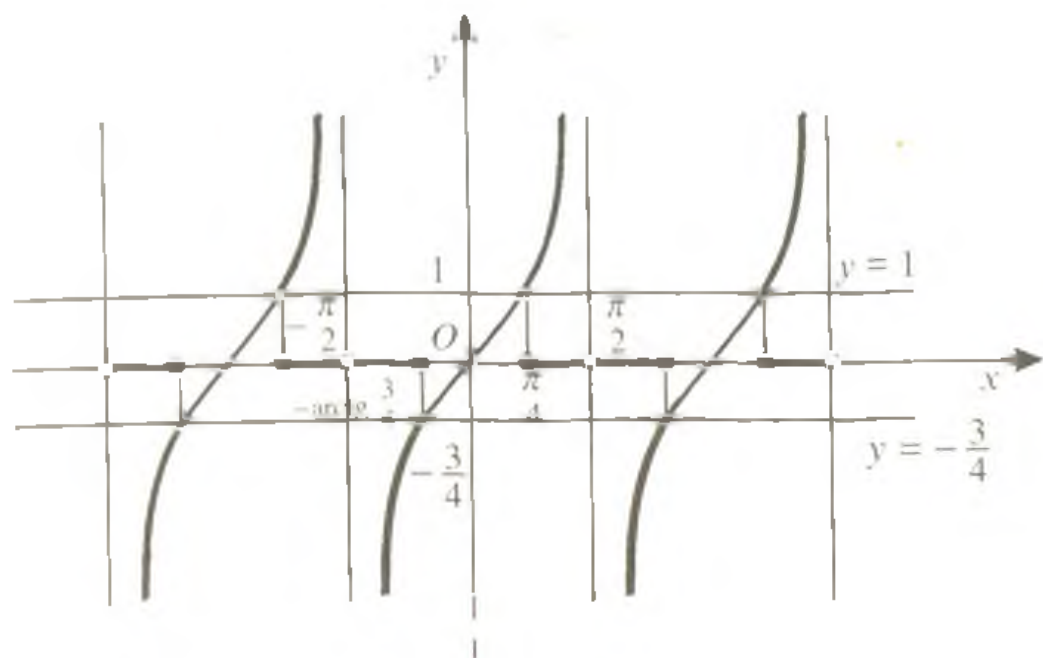

156-rasm

$$4y^2 - y - 3 > 0 \Leftrightarrow 4\left(y + \frac{3}{4}\right)(y - 1) \geq 0.$$

Bu tengsizlik yechimlari to'plamlarining birlashmasi

$(-\infty; -\frac{3}{4}] \cup [1; +\infty)$  dan iborat.  $x$  o'zgaruvchiga qaytib,

$$\begin{cases} \operatorname{tg} x \leq -\frac{3}{4}; \\ \operatorname{tg} x \geq 1 \end{cases}$$

tengsizliklar sistemasiga ega bo'lamiz. Bu sistemaning  $(-\frac{\pi}{2}; \frac{\pi}{2})$

oraliq uchun yechimi  $(-\frac{\pi}{2}; -\operatorname{arctg} \frac{3}{4}]$  va  $[\frac{\pi}{4}; \frac{\pi}{2})$  oraliqlar birlashmasidan iborat (156-rasm). Tangensning davriyligini hisobga olib berilgan tengsizlikning butun sonlar o'qidagi yechimlari to'plamini yozamiz:

$$\left(k\pi - \frac{\pi}{2}; k\pi - \operatorname{arctg} \frac{3}{4}\right] \cup \left[k\pi + \frac{\pi}{4}; \frac{\pi}{2} + k\pi\right), k \in \mathbb{Z}.$$

Javob:  $\left(k\pi - \frac{\pi}{2}; k\pi - \operatorname{arctg} \frac{3}{4}\right] \cup \left[k\pi + \frac{\pi}{4}; \frac{\pi}{2} + k\pi\right), k \in \mathbb{Z}.$

### Mustaqil ishlash uchun test topshiriqlari

1.  $\sin\left(3x - \frac{\pi}{2}\right) = 0$  tenglamani yeching.

- A)  $\frac{\pi}{6} + \frac{k\pi}{3}, k \in Z$ ; B)  $\frac{\pi}{4} + \frac{k\pi}{2}, k \in Z$ ; C)  $\frac{\pi}{3} + \frac{k\pi}{3}, k \in Z$ ;  
 D)  $\frac{\pi}{2} + k\pi, k \in Z$ ; E)  $k\pi, k \in Z$ .

2.  $4\cos^3 x + 4 = 0$  tenglamani yeching.

- A)  $\pi + 2k\pi, k \in Z$ ; B)  $\frac{\pi}{3} + \frac{2k\pi}{3}, k \in Z$ ; C)  $\frac{\pi}{2} + k\pi, k \in Z$ ;  
 D)  $2k\pi, k \in Z$ ; E)  $-\frac{\pi}{3} + \frac{k\pi}{3}, k \in Z$ .

3.  $4\cos^2 \frac{x}{2} - 3 = 0$  tenglamani yeching.

- A)  $\frac{\pi}{3} + 2k\pi, k \in Z$ ; B)  $\frac{2\pi}{3} + 4k\pi, k \in Z$ ; C)  $\pm \frac{\pi}{3} + 2k\pi, k \in Z$ ;  
 D)  $\frac{\pi}{3} + k\pi, k \in Z$ ; E)  $\pm \frac{\pi}{6} + 2k\pi, k \in Z$ .

4.  $4\sin^2 2x - 1 = 0$  tenglamani yeching.

- A)  $\pm \frac{\pi}{24} + \frac{k\pi}{2}, k \in Z$ ; B)  $\pm \frac{\pi}{3} + 2k\pi, k \in Z$ ; C)  $\pm \frac{\pi}{6} + k\pi, k \in Z$ ;  
 D)  $\pm \frac{\pi}{12} + \frac{k\pi}{2}, k \in Z$ ; E)  $(-1)^k - \frac{\pi}{12} + \frac{k\pi}{2}, k \in Z$ .

5.  $\sqrt{3} \operatorname{tg}\left(\frac{\pi}{6} - 3x\right) = 3$  tenglamani yeching.

- A)  $-\frac{\pi}{6} + \frac{k\pi}{3}, k \in Z$ ; B)  $\frac{\pi}{6} + \frac{k\pi}{3}, k \in Z$ ; C)  $\frac{\pi}{3} + \frac{k\pi}{2}, k \in Z$ ;  
 D)  $-\frac{\pi}{3} + \frac{k\pi}{3}, k \in Z$ ; E)  $-\frac{\pi}{18} + \frac{k\pi}{3}, k \in Z$ .

6.  $\sqrt{3} \operatorname{ctg}\left(\frac{\pi}{3} - 2x\right) = 3$  tenglamani yeching.

- A)  $\frac{\pi}{12} + \frac{k\pi}{2}, k \in Z$ ; B)  $\frac{\pi}{12} - k\pi, k \in Z$ ; C)  $\pm \frac{\pi}{12} + 2k\pi, k \in Z$ ;  
 D)  $\frac{k\pi}{2}, k \in Z$ ; E)  $\frac{\pi}{6} + k\pi, k \in Z$ .

7.  $\sin^2 x + 3\sin\left(\frac{\pi}{2} + x\right) = -3$  tenglamani  $[0; 2\pi]$  oraliqda nechta ildizi bor?

- A) yo'q; B) 4; C) 3; D) 2; E) 1.

8.  $\cos^2 x + 3\cos\left(\frac{\pi}{2} - x\right) = -3$  tenglamani yeching.

- A)  $k\pi, k \in Z$ ; B)  $\frac{\pi}{2} + k\pi, k \in Z$ ; C)  $-\frac{\pi}{2} + 2k\pi, k \in Z$ ;

D)  $\frac{\pi}{2} + 2k\pi, k \in \mathbb{Z}$ ; E)  $\emptyset$ .

9.  $\cos^2 x + 10 \sin^2 x = 3 \sin 2x$  tenglamani yeching.

A)  $\emptyset$ ; B)  $k\pi$ ; C)  $\frac{\pi}{4} + 2k\pi, k \in \mathbb{Z}$ ; D)  $\arctg \frac{7}{10} + k\pi, k \in \mathbb{Z}$ ;

E)  $-\arctg \frac{1}{10} + k\pi, k \in \mathbb{Z}$ .

10.  $\sqrt{3} \cos x = \sin^2 x \cos x$  tenglamaning  $[0; 360^\circ]$  oraliqdagi ildizlari yig'indisini toping.

A)  $90^\circ$ ; B)  $60^\circ$ ; C)  $360^\circ$ ; D)  $300^\circ$ ; E)  $150^\circ$ .

11.  $2\sin^2 2x - 5\cos 2x + 1 = 0$  tenglamaning  $[\pi; 2\pi]$  oraliqqa tegishli ildizlarini ko'rsating.

A)  $\frac{4\pi}{3}; \frac{5\pi}{3}$ ; B)  $\frac{7\pi}{6}; \frac{11\pi}{6}$ ; C)  $\frac{7\pi}{6}$ ;

D)  $\frac{5\pi}{3}$ ; E) ko'rsatilgan oraliqda ildizlari yo'q.

12.  $\sin x - \cos x = 1$  tenglamaning  $[-2\pi; 2\pi]$  oraliqda nechta ildizi bor?

A) 1; B) 2; C) 3; D) 4; E) ko'rsatilgan oraliqda ildizlari yo'q.

13\*.  $\frac{\sin 2x}{\operatorname{ctg} x - 1} = 0$  tenglamani yeching.

A)  $\frac{k\pi}{2}, k \in \mathbb{Z}$ ; B)  $\frac{\pi}{2} + k\pi, k \in \mathbb{Z}$ ; C)  $2k\pi, k \in \mathbb{Z}$ ;

D)  $\pi + 2k\pi, k \in \mathbb{Z}$ ; E)  $k\pi, k \in \mathbb{Z}$ .

14\*.  $\sin 3x = \cos x$  tenglamaning eng kichik musbat ildizini toping.

A)  $\frac{3\pi}{8}$ ; B)  $\frac{\pi}{4}$ ; C)  $\frac{\pi}{8}$ ; D)  $\frac{\pi}{12}$ ; E)  $\frac{\pi}{24}$ .

15\*.  $\cos 4x = \cos 6x$  tenglamaning  $[0; 180^\circ]$  oraliqdagi ildizlari yig'indisini toping.

A)  $216^\circ$ ; B)  $288^\circ$ ; C)  $360^\circ$ ; D)  $390^\circ$ ; E)  $540^\circ$ .

16\*.  $\operatorname{tg}\left(5x + \frac{\pi}{3}\right) \operatorname{ctg} 3x = 1$  tenglamani yeching.

A)  $-\frac{\pi}{6} + \frac{k\pi}{2}, k \in \mathbb{Z}$ ; B)  $-\frac{\pi}{6} + k\pi, k \in \mathbb{Z}$ ; C)  $-\frac{\pi}{6}$ ;

D)  $\frac{\pi}{12} + k\pi, k \in \mathbb{Z}$ ; E)  $\emptyset$ .

17.  $2\operatorname{ctg}^2 x \cdot \cos^2 x + 4\cos^2 x - \operatorname{ctg}^2 x - 2 = 0$  tenglamani yeching.

A)  $\frac{\pi}{2} + k\pi, k \in \mathbb{Z}$ ; B)  $\frac{\pi}{4} + k\pi, k \in \mathbb{Z}$ ; C)  $\frac{\pi}{4} + \frac{k\pi}{2}, k \in \mathbb{Z}$ ;

D)  $\frac{\pi}{2} + 2k\pi, k \in \mathbb{Z}$ ; E)  $\frac{\pi}{4} + 2k\pi, k \in \mathbb{Z}$ .

18.  $\sin^2 \frac{x}{2} - \cos \frac{x}{2} = 1$  tenglama  $[0; 2\pi]$  oraliqda nechta ildizga ega?

A) 4; B) 3; C) 2; D) 1; E) yo'q.

19\*.  $\operatorname{ctg}^2 x - \operatorname{tg}^2 x = 8\cos 2x$  tenglamani yeching.

A)  $\frac{\pi}{4} + 2k\pi, k \in \mathbb{Z}$ ; B)  $-\frac{\pi}{4} + 2k\pi, k \in \mathbb{Z}$ ;

C)  $\frac{\pi}{4} + 2k\pi; \frac{\pi}{8} + 2k\pi, k \in \mathbb{Z}$ ; D)  $\frac{\pi}{4} + \frac{k\pi}{2}; \frac{\pi}{8} + \frac{k\pi}{4}, k \in \mathbb{Z}$ ;

E)  $\frac{\pi}{8} + 2k\pi, k \in \mathbb{Z}$ .

20.  $\sin^2 x - \sin^3 x + \sin 8x = \cos\left(\frac{\pi}{2} - 7x\right)$  tenglamaning  $[0; 90^\circ]$  oraliqqa tegishli ildizlarni ko'rsating.

A)  $0; 36^\circ; 72^\circ$ ; B)  $36^\circ; 45^\circ$ ; C)  $30^\circ; 60^\circ$ ; D)  $36^\circ; 72^\circ$ ;

E)  $30^\circ; 60^\circ; 90^\circ$ .

21.  $\cos x + \cos 2x + \cos 3x + \cos 4x = 0$  tenglamani yeching.

A)  $\frac{\pi}{2} + k\pi; \frac{\pi}{5} + \frac{2k\pi}{5}, k \in \mathbb{Z}$ ; B)  $\frac{\pi}{2} + k\pi, k \in \mathbb{Z}$ ;

C)  $\frac{\pi}{4} + \frac{k\pi}{2}; \frac{\pi}{6} + \frac{k\pi}{3}, k \in \mathbb{Z}$ ; D)  $\frac{\pi}{5} + 2k\pi, k \in \mathbb{Z}$ ;

E)  $\pi + k\pi, k \in \mathbb{Z}$ .

22\*.  $\sin^2 2x + \sin^2 3x + \sin^2 4x + \sin^2 5x = 2$  tenglamaning  $(0; \pi)$  oraliqdagi eng kichik ildizini ko'rsating.

A) 0; B)  $\frac{\pi}{12}$ ; C)  $\frac{\pi}{14}$ ; D)  $\frac{\pi}{8}$ ; E)  $\frac{\pi}{4}$ .

23\*.  $5\sin x - \cos x = 5$  tenglamani yeching.

A)  $\frac{\pi}{2}$ ; B)  $\frac{\pi}{2} + 2k\pi, k \in \mathbb{Z}$ ; C)  $\frac{\pi}{2}; \operatorname{arctg} \frac{3}{2} + k\pi, k \in \mathbb{Z}$ ;

D)  $\frac{\pi}{2} + 2k\pi; 2\operatorname{arctg} \frac{3}{2} + 2k\pi, k \in \mathbb{Z}$ ; E)  $\frac{\pi}{2} + k\pi, k \in \mathbb{Z}$ .

24\*.  $4 \sin^2 x (1 + \cos 2x) = 1 - \cos 2x$  tenglamani yeching.

A)  $k\pi, k \in Z$ ; B)  $k\pi; \pm \frac{\pi}{3} + k\pi, k \in Z$ ; C)  $\pm \frac{\pi}{3} + k\pi, k \in Z$ ;

D)  $k\pi; \pm \frac{\pi}{3} + 2k\pi, k \in Z$ ; E)  $k\pi; \pm \frac{2}{3}\pi + 2k\pi, k \in Z$ .

25\*.  $\sin^3 x + \cos^3 x = 1$  tenglamani yeching.

A)  $k\pi, k \in Z$ ; B)  $\frac{\pi}{2} + 2k\pi, k \in Z$ ; C)  $2\pi$ ;

D)  $2k\pi; \frac{\pi}{2} + 2k\pi, k \in Z$ ; E)  $\pi + k\pi, k \in Z$ .

26\*.  $\sin^4 x + \cos^4 x = \sin x \cos x$  tenglamani yeching.

A)  $\frac{\pi}{4} + k\pi, k \in Z$ ; B)  $\frac{\pi}{4} + 2k\pi, k \in Z$ ; C)  $\frac{3\pi}{4} + k\pi, k \in Z$ ;

D)  $\frac{3\pi}{2} + k\pi, k \in Z$ ; E)  $\frac{\pi}{2} + 2k\pi, k \in Z$ .

27\*.  $\sin^6 x + \cos^6 x = \frac{13}{14} (\sin^4 x + \cos^4 x)$  tenglamani yeching.

A)  $\pm \frac{\pi}{6} + k\pi, k \in Z$ ; B)  $\pm \frac{\pi}{12} + \frac{k\pi}{2}, k \in Z$ ;

C)  $(-1)^k \frac{\pi}{6} + k\pi, k \in Z$ ; D)  $\frac{\pi}{12} + k\pi, k \in Z$ ;

E)  $\pm \frac{\pi}{8} + \frac{k\pi}{2}, k \in Z$ .

28\*.  $81^{\sin^2 x} + 81^{\cos^2 x} = 30$  tenglamani yeching.

A)  $\pm \frac{\pi}{3} + k\pi, k \in Z$ ; B)  $\frac{\pi}{6} + k\pi, k \in Z$ ; C)  $\frac{\pi}{6} + 2k\pi, k \in Z$ ;

D)  $\pm \frac{\pi}{6} + \frac{k\pi}{2}, k \in Z$ ; E)  $\pm \frac{\pi}{12} + \frac{k\pi}{2}, k \in Z$ .

29\*.  $\frac{\cos 4x + 1}{\operatorname{ctg} x - \operatorname{tg} x} = \frac{1}{2} \cos^4 2x - 8 \sin^4 x \cos^4 x$  tenglamani yeching.

A)  $\frac{\pi}{16} + \frac{k\pi}{4}, k \in Z$ ; B)  $\frac{3\pi}{4} + k\pi, k \in Z$ ; C)  $\frac{\pi}{12} + \frac{k\pi}{4}, k \in Z$ ;

D)  $\pm \frac{\pi}{12} + \frac{k\pi}{4}, k \in Z$ ; E)  $\pm \frac{\pi}{6} + 2k\pi, k \in Z$ .



$$30^* \cdot \frac{1}{1-\operatorname{tg} 2x} + \frac{2\cos^2 x - 1}{\cos 2x + \sin 2x} = \frac{2\sqrt{3}\operatorname{tg} 2x}{1-\operatorname{tg}^2 2x} \text{ tenglamani yeching.}$$

A)  $\frac{\pi}{6} + k\pi, k \in Z$ ; B)  $\frac{\pi}{6} + \frac{k\pi}{2}, k \in Z$ ; C)  $\frac{\pi}{12} + k\pi, k \in Z$ ;

D)  $\frac{\pi}{3} + k\pi, k \in Z$ ; E)  $\frac{\pi}{12} + \frac{k\pi}{2}, k \in Z$ .

$$31^* \cdot \begin{cases} \cos x + \cos y = \sqrt{3}, \\ x + y = \frac{\pi}{3} \end{cases} \text{ sistemani yeching.}$$

A)  $(\frac{\pi}{6} + 2k\pi; \frac{\pi}{6} - 2k\pi), k \in Z$ ; B)  $(\frac{\pi}{3} + 2k\pi; \frac{\pi}{3} - 2k\pi), k \in Z$ ;

C)  $(\frac{\pi}{6} + k\pi; \frac{\pi}{6} - k\pi), k \in Z$ ; D)  $(\frac{\pi}{3} + k\pi; \frac{\pi}{3} + k\pi), k \in Z$ ;

E)  $(\pm \frac{\pi}{6} + 2k\pi; \pm \frac{\pi}{6} + 2k\pi), k \in Z$ .

$$32^* \cdot \cos x \cos 2x \cos 4x \cos 8x = \frac{1}{8} \cos 15x \text{ tenglamani yeching.}$$

A)  $\frac{\pi}{12} + k\pi, k \in Z$ ; B)  $\frac{k\pi}{14}, k \in Z$ ; C)  $\frac{k\pi}{30}, k \in Z$ ;

D)  $\frac{k\pi}{16}, k \in Z$ ; E)  $\frac{k\pi}{12}, k \in Z$ .

33\*.  $\operatorname{tg} x + \operatorname{tg} 2x - \operatorname{tg} 3x = 0$  tenglamaning  $(-\frac{\pi}{2}; \frac{\pi}{2})$  oraliqdagi yechimlari yig'indisini toping.

A) 0; B)  $\frac{\pi}{6}$ ; C)  $\frac{\pi}{4}$ ; D)  $\frac{5\pi}{12}$ ; E)  $-\frac{\pi}{6}$ .

$$34. 9^{\cos x} + 2 \cdot 3^{\cos x} = 15 \text{ tenglamani yeching.}$$

A)  $2k\pi, k \in Z$ ; B) 0; C)  $2\pi$ ; D)  $\pi + 2k\pi, k \in Z$ ;

E)  $\frac{\pi}{2} + 2k\pi, k \in Z$ .

$$35. \sqrt{1 - \cos x} = \sin x \text{ tenglamani yeching.}$$

A)  $\frac{\pi}{2} + k\pi; 2k\pi, k \in Z$ ; B)  $\frac{\pi}{2} + 2k\pi, k \in Z$ ;

C)  $\frac{\pi}{2} + 2k\pi; 2k\pi, k \in Z$ ; D)  $2k\pi, k \in Z$ ; E)  $-\pi + 2k\pi, k \in Z$ .

$$36^* \cdot \cos^{10} x + \sin^{15} x = 1 \text{ tenglamani yeching.}$$

A)  $k\pi; \frac{\pi}{2} + k\pi, k \in Z$ ; B)  $2k\pi, k \in Z$ ; C)  $2k\pi; \frac{\pi}{2} + 2k\pi, k \in Z$ ;

D)  $\pi + 2k\pi; \frac{\pi}{2} + k\pi, k \in Z$ ; E)  $k\pi; \frac{\pi}{2} + 2k\pi, k \in Z$ .

37\*.  $\frac{\cos 3x}{\sin 3x - 2\sin x} = \operatorname{tg} x$  tenglamani yeching.

A)  $\frac{\pi}{4} + \frac{k\pi}{2}, k \in \mathbb{Z}$ ; B)  $\frac{\pi}{4} + 2k\pi, k \in \mathbb{Z}$ ; C)  $\frac{\pi}{4} + k\pi, k \in \mathbb{Z}$ ;

D)  $\frac{\pi}{3} + \frac{k\pi}{2}, k \in \mathbb{Z}$ ; E)  $\frac{\pi}{3} + k\pi, k \in \mathbb{Z}$ .

38\*.  $\sqrt{1 - \sin 2x} = \sin 3x + \cos 3x$  tenglama  $\left[ \frac{3\pi}{2}; 2\pi \right]$  oraliqda

nechta ildizga ega?

A) 4; B) 3; C) 2; D) 1; E) ko'rsatilgan oraliqda ildizi yo'q.

39\*.  $\log_3(-\cos x) - \log_9 \sin x + \frac{1}{4} = -\log_9 2$  tenglamani yeching.

A)  $(-1)^k \frac{\pi}{6} + k\pi, k \in \mathbb{Z}$ ; B)  $(-1)^k \frac{\pi}{3} + k\pi, k \in \mathbb{Z}$ ;

C)  $\frac{5\pi}{6} + 2k\pi, k \in \mathbb{Z}$ ; D)  $\frac{\pi}{3} + 2k\pi, k \in \mathbb{Z}$ ; E)  $\frac{2\pi}{3} + 2k\pi, k \in \mathbb{Z}$ .

40\*.  $5\sin 3x - 6\cos 3x = a$  tenglama  $a$  ning qanday qiymatlarida yechimga ega?

A)  $-1 \leq a \leq 1$ ; B)  $-\frac{5}{6} \leq a \leq \frac{5}{6}$ ; C)  $-\sqrt{11} \leq a \leq \sqrt{11}$ ;

D)  $-\sqrt{61} \leq a \leq \sqrt{61}$ ; E)  $-\sqrt{14} \leq a \leq \sqrt{14}$ .

41.  $3 \arccos(2x + 3) = \frac{5\pi}{2}$  tenglamani yeching.

A)  $\frac{\sqrt{3}}{2}$ ; B)  $-\frac{\sqrt{3}}{2}$ ; C)  $-\frac{6+\sqrt{3}}{4}$ ; D)  $-\frac{6-\sqrt{3}}{4}$ ; E)  $-1,25$ .

42\*.  $\arcsin x \cdot \arccos x = \frac{\pi^2}{18}$  tenglamani yeching.

A)  $\frac{\sqrt{3}}{2}; \frac{\sqrt{2}}{2}$ ; B)  $-\frac{\sqrt{3}}{2}; \frac{1}{2}$ ; C)  $\frac{\sqrt{3}}{2}; \frac{1}{2}$ ; D)  $\frac{1}{2}; -\frac{1}{2}$ ; E)  $\frac{\sqrt{2}}{2}; \frac{1}{2}$ .

43.  $\operatorname{arctg}(1-x) + \operatorname{arctg}(1+x) = \frac{\pi}{4}$  tenglamani yeching.

A)  $\pm 2$ ; B)  $\pm\sqrt{2}$ ; C)  $\pm\sqrt{3}$ ; D)  $\sqrt{2}; \sqrt{3}$ ; E)  $1; \sqrt{2}$ .

44.  $2(\arcsin x)^2 + \pi^2 = 3\pi \arcsin x$  tenglamani yeching.

A) 1; B) 0; C)  $\frac{\sqrt{3}}{2}$ ; D)  $\frac{1}{2}$ ; E)  $\frac{\sqrt{2}}{2}$ .

45\*.  $2\arcsin 2x = \arcsin 7x$  tenglama nechta ildizga ega?

A) 1; B) 2; C) 3; D) 4; E)  $\emptyset$ .

46.  $\sqrt{2} \sin\left(\frac{\pi}{2} - 2x\right) > 1$  tengsizlikni yeching.

- A)  $\left(2k\pi - \frac{\pi}{4}; 2k\pi + \frac{\pi}{4}\right); k \in Z$ ; B)  $\left(k\pi - \frac{\pi}{4}; k\pi + \frac{\pi}{4}\right); k \in Z$ ;  
 C)  $\left(2k\pi - \frac{\pi}{8}; 2k\pi + \frac{\pi}{8}\right); k \in Z$ ; D)  $\left(k\pi - \frac{\pi}{8}; k\pi + \frac{\pi}{8}\right); k \in Z$ ;  
 E)  $\left(k\pi + \frac{\pi}{8}; k\pi + \frac{3\pi}{8}\right); k \in Z$ .

47.  $2 \cos\left(\frac{3\pi}{2} + 3x\right) \leq -\sqrt{2}$  tengsizlikni yeching.

- A)  $\left[\frac{2k\pi - 5\pi}{3}; \frac{\pi}{12} + \frac{2k\pi}{3}\right]; k \in Z$ ; B)  $\left[\frac{2k\pi - \pi}{3}; \frac{2k\pi - \pi}{12}\right]; k \in Z$ ;  
 C)  $\left[\frac{k\pi}{3} - \frac{5\pi}{12}; \frac{\pi}{12} + \frac{k\pi}{3}\right]; k \in Z$ ; D)  $\left[\frac{k\pi}{3} - \frac{\pi}{4}; \frac{k\pi}{3} - \frac{\pi}{12}\right]; k \in Z$ ;  
 E)  $\left[\frac{2k\pi}{3} + \frac{\pi}{12}; \frac{3\pi}{12} + \frac{2k\pi}{3}\right]; k \in Z$ .

48.  $\operatorname{tg}\left(\pi + \frac{x}{3}\right) + 1 \geq 0$  tengsizlikni yeching.

- A)  $\left[k\pi - \frac{\pi}{4}; \frac{\pi}{2} + k\pi\right); k \in Z$ ; B)  $\left[k\pi + \frac{\pi}{4}; \frac{\pi}{2} + k\pi\right); k \in Z$ ;  
 C)  $\left[3k\pi - \frac{3\pi}{4}; \frac{3\pi}{2} + 3k\pi\right); k \in Z$ ; D)  $\left[k\pi - \frac{3\pi}{4}; \frac{3\pi}{2} + k\pi\right); k \in Z$ ;  
 E)  $\left(3k\pi - \frac{3\pi}{2}; \frac{3\pi}{2} + 3k\pi\right); k \in Z$ .

49.  $\operatorname{ctg}\left(\frac{3\pi}{2} - \frac{x}{2}\right) \leq \sqrt{3}$  tengsizlikni yeching.

- A)  $\left(2k\pi - \pi; \frac{2\pi}{3} + 2k\pi\right]; k \in Z$ ; B)  $\left(k\pi - \frac{\pi}{2}; \frac{\pi}{3} + k\pi\right]; k \in Z$ ;  
 C)  $\left(2k\pi - \pi; \frac{\pi}{3} + 2k\pi\right]; k \in Z$ ; D)  $\left(k\pi - \frac{\pi}{2}; \frac{\pi}{6} + k\pi\right]; k \in Z$ ;  
 E)  $\left(-\pi; \frac{2\pi}{3}\right]$ .

50.  $\frac{1}{2} < \sin x \leq \frac{\sqrt{2}}{2}$  tengsizlikning  $[0; 2\pi]$  oraliqdagi yechimlarini toping.

- A)  $\left(\frac{\pi}{6}; \frac{\pi}{4}\right] \cup \left[\frac{3\pi}{4}; \frac{5\pi}{6}\right)$ ; B)  $\left(0; \frac{\pi}{4}\right] \cup \left[\frac{3\pi}{4}; 2\pi\right)$ ; C)  $\left(\frac{\pi}{6}; \frac{5\pi}{6}\right)$ ;  
 D)  $\left(\frac{\pi}{6} + 2k\pi; \frac{\pi}{4} + 2k\pi\right); k \in Z$ ;  
 E)  $\left(\frac{\pi}{6} + 2k\pi; \frac{\pi}{4} + 2k\pi\right] \cup \left[\frac{3\pi}{4} + 2k\pi; \frac{5\pi}{6} + 2k\pi\right); k \in Z$ .

51.  $-\frac{\sqrt{3}}{2} \leq \cos x < \frac{2}{3}$  tengsizlikni yeching.

A)  $\left[2k\pi - \frac{5\pi}{6}; 2k\pi - \arccos \frac{2}{3}\right), k \in Z;$

B)  $\left[2k\pi - \frac{5\pi}{6}; 2k\pi - \arccos \frac{2}{3}\right) \cup \left(\arccos \frac{2}{3} + 2k\pi; \frac{5\pi}{6} + 2k\pi\right], k \in Z;$

C)  $\left(2k\pi - \frac{5\pi}{6}; 2k\pi - \arccos \frac{2}{3}\right], k \in Z;$

D)  $\left(2k\pi - \frac{5\pi}{6}; 2k\pi - \arccos \frac{2}{3}\right) \cup \left[\arccos \frac{2}{3} + 2k\pi; \frac{5\pi}{6} + 2k\pi\right), k \in Z;$

E)  $\left(\arccos \frac{2}{3} + 2k\pi; \frac{5\pi}{6} + 2k\pi\right), k \in Z.$

52.  $2\operatorname{tg}^2 2x - 1 > 0$  tengsizlikning  $\left(-\frac{\pi}{2}; \frac{\pi}{2}\right)$  oraliqdagi yechimlarini toping.

A)  $\left(k\pi - \frac{\pi}{2}; k\pi - \frac{1}{2} \operatorname{arctg} \frac{1}{\sqrt{2}}\right), k \in Z;$

B)  $\left(k\pi + \frac{\pi}{2}; k\pi + \operatorname{arctg} \frac{1}{\sqrt{2}}\right), k \in Z;$

C)  $\left(\frac{k\pi}{2} - \frac{\pi}{4}; \frac{k\pi}{2} - \frac{1}{2} \operatorname{arctg} \frac{1}{\sqrt{2}}\right) \cup \left(\frac{k\pi}{2} + \frac{1}{2} \operatorname{arctg} \frac{1}{\sqrt{2}}; \frac{k\pi}{2} + \frac{\pi}{4}\right), k \in Z;$

D)  $\left(-\frac{\pi}{4}; -\frac{1}{2} \operatorname{arctg} \frac{1}{\sqrt{2}}\right) \cup \left(\frac{1}{2} \operatorname{arctg} \frac{1}{\sqrt{2}}; \frac{\pi}{4}\right), k \in Z;$

E)  $\left(-\frac{1}{2} \operatorname{arctg} \frac{1}{\sqrt{2}}; \frac{1}{2} \operatorname{arctg} \frac{1}{\sqrt{2}}\right).$

53.  $2\sin^2 x - 5\sin x + 2 < 0$  tengsizlikning  $[0; 2\pi]$  oraliqdagi yechimlari to'plamini toping.

A)  $\left(\frac{\pi}{6}; \frac{5\pi}{6}\right);$  B)  $\left[0; \frac{\pi}{6}\right) \cup \left(\frac{5\pi}{6}; 2\pi\right];$  C)  $\left[0; \frac{\pi}{3}\right] \cup \left[\frac{2\pi}{3}; 2\pi\right];$

D)  $\left[0; \frac{\pi}{3}\right) \cup \left(\frac{2\pi}{3}; 2\pi\right];$  E)  $\emptyset.$

54\*.  $y = \sqrt{1 - 2\sin^2 x} + \sqrt{\sin 2x}$  funksiyaning aniqlanish sohasini toping.

A)  $\left[k\pi - \frac{\pi}{4}; k\pi + \frac{\pi}{4}\right], k \in Z;$  B)  $\left[k\pi; \frac{\pi}{2}\right], k \in Z;$

C)  $\left[k\pi; \frac{\pi}{4} + k\pi\right], k \in Z;$  D)  $\left[0; \frac{\pi}{2}\right];$  E)  $\left[2k\pi; \frac{\pi}{2} + 2k\pi\right], k \in Z.$

55.  $f(x) = \sqrt{\cos\left(x - \frac{\pi}{4}\right)}$  funksiyaning aniqlanish sohasini toping.

A)  $\left[-\frac{\pi}{4}; \frac{\pi}{4}\right]$ ; B)  $[0; \pi]$ ; C)  $\left[0; \frac{\pi}{2}\right]$ ;

D)  $\left[-\frac{\pi}{4} + 2k\pi; \frac{3\pi}{4} + 2k\pi\right] k \in Z$ ; E)  $\left[-\frac{\pi}{4} + 2k\pi; \frac{\pi}{4} + 2k\pi\right] k \in Z$ .

56.  $y = 3\sqrt{\sin 2x} - 2\sqrt{\operatorname{ctg} 2x}$  funksiyaning aniqlanish sohasini toping.

A)  $\left(k\pi; \frac{\pi}{4} + k\pi\right), k \in Z$ ; B)  $\left(k\pi; \frac{\pi}{2} + k\pi\right), k \in Z$ ;

C)  $\left(\frac{\pi}{2} + k\pi; \pi + k\pi\right), k \in Z$ ; D)  $(0; \pi)$ ; E)  $\left(\frac{3\pi}{2} + k\pi; 2k\pi\right), k \in Z$ .

57\*.  $y = \sqrt{1 + \log_{\frac{1}{2}} \cos x}$  funksiya  $x$  ning qanday qiymatlarida

aniqlangan ( $x \in [0; 2\pi]$ )?

A)  $\left[0; \frac{\pi}{3}\right] \cup \left[\frac{5\pi}{3}; 2\pi\right]$ ; B)  $\left[0; \frac{\pi}{2}\right] \cup \left[\frac{3\pi}{2}; 2\pi\right]$ ; D)  $[0; \pi]$ ;

E)  $\left[0; \frac{\pi}{4}\right] \cup \left[\frac{7\pi}{4}; 2\pi\right]$ .

58\*.  $\cos x < \sin x$  tengsizlikni yeching.

A)  $\left(\frac{\pi}{4} + 2k\pi; \frac{5\pi}{4} + 2k\pi\right), k \in Z$ ; B)  $\left(\frac{\pi}{4} + k\pi; \frac{3\pi}{4} + k\pi\right), k \in Z$ ;

C)  $\left(\frac{\pi}{4} + 2k\pi; \frac{3\pi}{4} + 2k\pi\right), k \in Z$ ; D)  $\left(\frac{\pi}{4} + k\pi; \frac{5\pi}{4} + k\pi\right), k \in Z$ ;

E)  $(2k\pi; \pi + 2k\pi), k \in Z$ .

59.  $\left(\frac{\pi}{6} - \frac{e}{6}\right)^{\ln(2\cos x)} \geq 1$  tengsizlikni yeching ( $x \in [0; 2\pi]$ ).

A)  $\left[\frac{\pi}{3}; \frac{\pi}{2}\right] \cup \left(\frac{3\pi}{2}; \frac{5\pi}{3}\right]$ ; B)  $\left[\frac{\pi}{3}; \frac{\pi}{2}\right] \cup \left[\frac{3\pi}{2}; \frac{5\pi}{3}\right]$ ; C)  $\left[\frac{3\pi}{2}; \frac{5\pi}{3}\right]$ ;

D)  $\left[\frac{\pi}{3}; \frac{\pi}{2}\right]$ ; E)  $\left[\frac{\pi}{6}; \frac{\pi}{2}\right] \cup \left(\frac{3\pi}{2}; \frac{5\pi}{6}\right]$ .

60\*.  $y = \arccos(2\sin x)$  funksiyaning aniqlanish sohasiga tegishli bo'lgan  $x$  ning  $[-\pi; \pi]$  kesmadagi barcha qiymatlarini aniqlang.

A)  $\left[-\pi; -\frac{2\pi}{3}\right] \cup \left[-\frac{\pi}{3}; \frac{\pi}{3}\right] \cup \left[\frac{2\pi}{3}; \pi\right]$ ; B)  $\left[-\frac{\pi}{3}; \frac{\pi}{3}\right]$ ;

C)  $\left[-\frac{\pi}{4}; \frac{\pi}{4}\right]$ ; D)  $\left[-\frac{\pi}{6}; \frac{\pi}{6}\right]$ ; E)  $\left[-\pi; -\frac{5\pi}{6}\right] \cup \left[-\frac{\pi}{6}; \frac{\pi}{6}\right] \cup \left[\frac{5\pi}{6}; \pi\right]$ .

61\*.  $\frac{2\sin 3x - 4}{2x - 3x^2 + 1} < 0$  tengsizlik nechta butun yechimga ega?

A) cheksiz ko'p; B) 4; C) 3; D) 2; E) 1.

62\*.  $\sin x + \frac{1}{2} \sin 2x + \frac{1}{3} \sin 3x > 0$  tengsizlikni yeching.

A)  $(2k\pi; \pi + 2k\pi)$ ,  $k \in \mathbb{Z}$ ; B)  $\left(k\pi; \frac{\pi}{2} + k\pi\right)$ ,  $k \in \mathbb{Z}$ ;

C)  $\left(\frac{2k\pi}{3}; \frac{\pi}{3} + \frac{2k\pi}{3}\right)$ ,  $k \in \mathbb{Z}$ ; D)  $\left(2k\pi; \frac{\pi}{2} + 2k\pi\right)$ ,  $k \in \mathbb{Z}$ ;

E)  $\left(-\frac{\pi}{2} + 2k\pi; \frac{\pi}{2} + 2k\pi\right)$ ,  $k \in \mathbb{Z}$ .

63\*.  $\arcsin x < \arcsin(1 - x)$  tengsizlikni yeching.

A)  $\left(-\infty; \frac{1}{2}\right)$ ; B)  $(0; 2)$ ; C)  $\emptyset$ ; D)  $[-1; 1]$ ; E)  $\left[0; \frac{1}{2}\right)$ .

64\*.  $\arcsin x > \arccos x$  tengsizlikni yeching.

A)  $\left[0; \frac{\sqrt{2}}{2}\right)$ ; B)  $[0; 1]$ ; C)  $\left[\frac{\sqrt{2}}{2}; 1\right)$ ; D)  $\left(\frac{\sqrt{2}}{2}; 1\right)$ ; E)  $\emptyset$ .

65\*.  $x^2 - 4x + \arccos(x^2 - 4x + 5) < 0$  tengsizlikni yeching.

A)  $\{2\}$ ; B)  $[-1; 1]$ ; C)  $[-2; 2]$ ; D)  $(-2; 0)$ ; E)  $(0; 2)$ .

## HOSILA VA UNING TATBIQLARI

## 1-§. Funksiyaning limiti

## 1.1. Funksiyaning nuqtadagi limiti.

Ta'rif. Agar  $y = f(x)$  funksiya  $x = a$  nuqtaning biror atrofida aniqlangan bo'lib ( $x = a$  nuqtaning o'zida aniqlanmagan bo'lishi mumkin), istalgan  $\varepsilon > 0$  son uchun shunday  $\delta > 0$  son mavjud bo'lsaki,  $|x - a| < \delta$  tengsizlikni qanoatlantiradigan barcha  $x \neq a$  nuqtalar uchun  $|f(x) - b| < \varepsilon$  tengsizlik bajarilsa, u holda  $b$  chekli son  $y = f(x)$  funksiyaning  $x = a$  nuqtadagi (yoki  $x \rightarrow a$  dagi ( $x$   $a$  ga intilgandagi)) limiti deyiladi va quyidagicha yoziladi:

$$\lim_{x \rightarrow a} f(x) = b.$$

Keltirilgan ta'rif quyidagi geometrik talqinga ega: agar istalgan  $\varepsilon > 0$  son uchun shunday  $\delta > 0$  son mavjud bo'lsaki,  $a$  dan masofasi  $\delta$  dan ortiq bo'lmagan  $(a - \delta; a + \delta)$  oraliqdagi barcha  $x$  lar uchun  $f(x)$  funksiyaning qiymatlari  $(b - \varepsilon; b + \varepsilon)$  oraliqqa tushsa,  $b$  son  $f(x)$  funksiyaning  $x \rightarrow a$  dagi limiti bo'ladi (157-rasm).

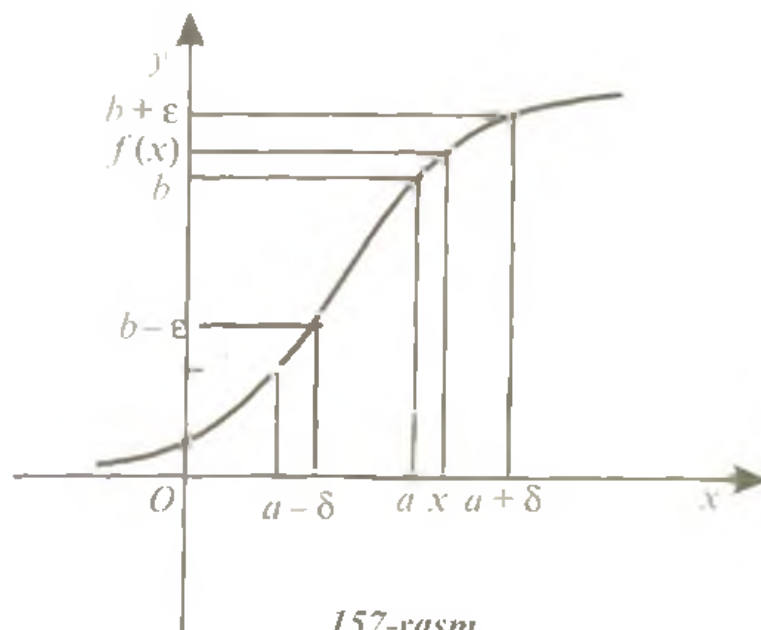

1-misol.  $\lim_{x \rightarrow 3} (3x - 4) = 5$  ekanligini funksiya limitining ta'rifidan foydalanib isbotlang.

Yechilishi. Ixtiyoriy  $\varepsilon > 0$  ni olamiz va  $|x - 3| < \delta$  tengsizlik o'rinli bo'lgan barcha  $x$  lar uchun  $|(3x - 4) - 5| < \varepsilon$  tengsizlik bajarilishini ko'rsatamiz:

$$|(3x - 4) - 5| < \varepsilon \Leftrightarrow |3x - 9| < \varepsilon \Leftrightarrow 3|x - 3| < \varepsilon \Leftrightarrow |x - 3| < \frac{\varepsilon}{3}.$$

Shunday qilib, agar  $\delta = \frac{\varepsilon}{3}$  deb olinsa, u holda  $|x - 3| < \delta$  tengsizlikning bajarilishidan

$$|(3x - 4) - 5| < \varepsilon$$

tengsizlikning bajarilishi kelib chiqadi. Demak, ta'rifga ko'ra

$$\lim_{x \rightarrow 3} (3x - 4) = 5.$$

2-misol.  $\lim_{x \rightarrow 2} \frac{x^2 - 4}{x - 2} = 4$  ekanligini ta'rifdan foydalanib isbotlang.

Yechilishi. Berilgan funksiya  $x = 2$  nuqtadan boshqa barcha nuqtalarda aniqlangan. Shuning uchun  $x \neq 2$  da

$$|f(x) - 4| = \left| \frac{x^2 - 4}{x - 2} - 4 \right| < \varepsilon \Leftrightarrow \left| \frac{(x - 2)(x + 2)}{x - 2} - 4 \right| < \varepsilon \Leftrightarrow |x + 2 - 4| < \varepsilon \Leftrightarrow |x - 2| < \varepsilon.$$

Shunday qilib, agar  $|x - 2| < \varepsilon$  ( $\delta = \varepsilon$ ) va  $x \neq 2$  bo'lsa,

$$\left| \frac{x^2 - 4}{x - 2} - 4 \right| < \varepsilon.$$

ya'ni nuqtaning  $\varepsilon$  atrofidan olingan barcha  $x \neq 2$  lar uchun

$$\left| \frac{x^2 - 4}{x - 2} - 4 \right| < \varepsilon.$$

Demak,

$$\lim_{x \rightarrow 2} \frac{x^2 - 4}{x - 2} = 4.$$

**1.2. Bir tomonlama limitlar.** Ko'pincha  $y = f(x)$  funksiyaning  $a$  nuqtadagi **bir tomonlama** limitlari, ya'ni **o'ngdan** limiti va **chapdan** limiti qaraladi. Bunda limitning ta'rifida  $x \neq a$  shartni  $x > a$  ( $x < a$ ) sharti bilan almashtiriladi. Masalan, o'ngdan limit quyidagicha ta'riflanadi:



Agar istalgan  $\varepsilon > 0$  son uchun shunday  $\delta > 0$  son mavjud bo'lsaki,  $|x - a| < \delta$  tengsizlikni qanoatlantiruvchi barcha  $x > a$  nuqtalar uchun  $|f(x) - b| < \varepsilon$  tengsizlik bajarilsa, u holda  $b$  son  $f(x)$  funksiyaning  $a$  nuqtadagi o'ngdan limiti deyiladi va  $\lim_{x \rightarrow a+0} f(x) = b$  kabi belgilanadi.

Chapdan limit  $\lim_{x \rightarrow a-0} f(x)$  belgi bilan belgilanadi.

Agar funksiyaning ikkala bir tomonlama limiti mavjud bo'lib, ular o'zaro teng bo'lsa,  $f(x)$  funksiya  $x \rightarrow a$  da **ikki tomonlama** limitga ega yoki oddiygina  $x \rightarrow a$  da limitga ega deyiladi.

### 1.3. Funksiyaning cheksizlikdagi limiti.

Ta'rif. Agar  $y = f(x)$  funksiya  $x$  ning yetarlicha katta qiymatlarida aniqlangan bo'lib, ixtiyoriy  $\varepsilon > 0$  son uchun shunday  $N > 0$  mavjud bo'lsaki,  $|x| > N$  tengsizlikni qanoatlantiradigan barcha  $x$  lar uchun  $|f(x) - b| < \varepsilon$  tengsizlik bajarilsa, o'zgarmas  $b$  son  $f(x)$  funksiyaning  $x \rightarrow +\infty$  ( $x$  cheksizga intilgandagi)dagi limiti deyiladi va

$$\lim_{x \rightarrow +\infty} f(x) = b$$

kabi yoziladi.

Bu ta'rifning geometrik ma'nosi  $y = f(x)$  funksiya grafigidagi absissalari  $N$  dan katta bo'lgan barcha nuqtalarning ordinatalari  $b - \varepsilon$  va  $b + \varepsilon$  sonlar orasida yotishini, ya'ni  $x$  ning  $N$  sonidan katta barcha qiymatlari uchun  $f(x)$  funksiya grafigi  $y = b - \varepsilon$  va  $y = b + \varepsilon$  to'g'ri chiziqlar bilan chegaralangan kamarda yotishini anglatadi (158-rasm).

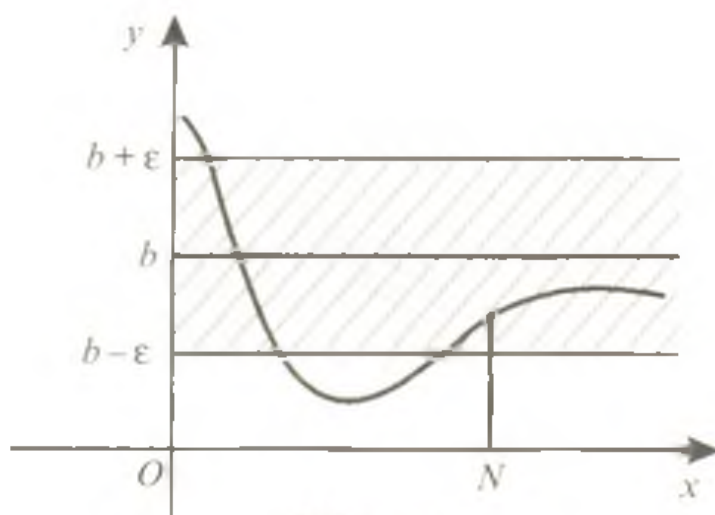

158-rasm

3-misol.  $\lim_{x \rightarrow +\infty} \left( \frac{x+1}{x} \right) = 1$  ekanligini ta'rifdan foydalanib isbotlang.

Yechilishi:  $|x| > N$  da istalgan  $\varepsilon > 0$  uchun

$$\left| \left( \frac{x+1}{x} \right) - 1 \right| < \varepsilon$$

bo'lishini ko'rsatamiz. Bunda  $N$  son  $\varepsilon$  ning tanlanishiga bog'liq.

$$\left| \left( \frac{x+1}{x} \right) - 1 \right| < \varepsilon \Leftrightarrow \left| \frac{x+1-x}{x} \right| < \varepsilon \Leftrightarrow \frac{1}{|x|} < \varepsilon \Leftrightarrow |x| > \frac{1}{\varepsilon} = N.$$

Shunday qilib,

$$\lim_{x \rightarrow +\infty} \left( \frac{x+1}{x} \right) = \lim_{x \rightarrow +\infty} \left( 1 + \frac{1}{x} \right) = 1.$$

#### 1.4. Funktsiyalarning limitlari haqidagi asosiy teoremlar.

1. O'zgarmasning limiti shu o'zgarmasning o'ziga teng:

$$\lim_{x \rightarrow a} c = c.$$

2. O'zgarmas ko'paytuvchini limit belgisidan tashqariga chiqarish mumkin:

$$\lim_{x \rightarrow a} (k \cdot f(x)) = k \cdot \lim_{x \rightarrow a} f(x).$$

3. Funktsiyalar yig'indisining (ayirmasining) limiti funktsiyalar limitlarining yig'indisiga (ayirmasiga) teng.

$$\lim_{x \rightarrow a} (f(x) \pm \varphi(x)) = \lim_{x \rightarrow a} f(x) \pm \lim_{x \rightarrow a} \varphi(x).$$

4. Funktsiyalar ko'paytmasining limiti shu funktsiyalar limitlarining ko'paytmasiga teng:

$$\lim_{x \rightarrow a} (f(x) \cdot \varphi(x)) = \lim_{x \rightarrow a} f(x) \cdot \lim_{x \rightarrow a} \varphi(x).$$

5. Agar bo'luvchining limiti nolga teng bo'lmasa, ikki funksiya nisbatining limiti shu funktsiyalar limitlarining nisbatiga teng:

$$\lim_{x \rightarrow a} \frac{f(x)}{\varphi(x)} = \frac{\lim_{x \rightarrow a} f(x)}{\lim_{x \rightarrow a} \varphi(x)} \quad (\lim_{x \rightarrow a} \varphi(x) \neq 0).$$

6. Agar  $f_1(x)$ ,  $f_2(x)$  va  $\varphi(x)$  funktsiyalarning mos qiymatlari uchun

$$f_1(x) \leq \varphi(x) \leq f_2(x)$$

tengsizlik bajarilib,  $\lim_{x \rightarrow a} f_1(x) = \lim_{x \rightarrow a} f_2(x) = A$  bo'lsa, u holda

$\lim_{x \rightarrow a} \varphi(x) = A$  bo'ladi.

Funksiyalarning limitlarini topishga doir bir necha misollar qaraymiz.

4-misol.  $\lim_{x \rightarrow 4} \frac{5x-4}{3x+4}$  ni hisoblang.

Yechilishi. 2 va 5-teoremlardan foydalanamiz:

$$\lim_{x \rightarrow 4} \frac{5x-4}{3x+4} = \frac{\lim_{x \rightarrow 4} (5x-4)}{\lim_{x \rightarrow 4} (3x+4)} = \frac{5 \lim_{x \rightarrow 4} x - 4}{3 \lim_{x \rightarrow 4} x + 4} = \frac{5 \cdot 4 - 4}{3 \cdot 4 + 4} = \frac{16}{16} = 1.$$

Javob: 1.

5-misol.  $\lim_{x \rightarrow 2} \frac{x^2 - 6x + 8}{x^2 - 5x + 6}$  ni hisoblang.

Yechilishi.  $x \rightarrow 2$  da kasrning surat va maxraji nolga intilganligi sababli bo'linmaning limiti haqidagi 5-teoremani bevosita tatbiq etib bo'lmaydi. Lekin berilgan kasrning surat va maxrajini ko'paytuvchilarga ajratib uni qisqartirish mumkin. Shunday qilib,

$$\lim_{x \rightarrow 2} \frac{x^2 - 6x + 8}{x^2 - 5x + 6} = \lim_{x \rightarrow 2} \frac{(x-2)(x-4)}{(x-2)(x-3)} = \lim_{x \rightarrow 2} \frac{x-4}{x-3} = \frac{\lim_{x \rightarrow 2} x - 4}{\lim_{x \rightarrow 2} x - 3} = \frac{2-4}{2-3} = \frac{-2}{-1} = 2.$$

Javob: 2.

6-misol.  $\lim_{x \rightarrow 0} \frac{x + 2\sqrt{x}}{x - 3\sqrt{x}}$  ni toping.

Yechilishi: Funksiya  $x > 0$ ,  $x \neq 9$  da aniqlangan, shu sababli uning o'ngdan limitini topamiz:

$$\lim_{x \rightarrow 0+0} \frac{x + 2\sqrt{x}}{x - 3\sqrt{x}} = \lim_{x \rightarrow 0+0} \frac{\sqrt{x}(\sqrt{x} + 2)}{\sqrt{x}(\sqrt{x} - 3)} = \frac{\lim_{x \rightarrow 0+0} (\sqrt{x} + 2)}{\lim_{x \rightarrow 0+0} (\sqrt{x} - 3)} = -\frac{2}{3}.$$

Javob:  $-\frac{2}{3}$ .

7-misol.  $\lim_{x \rightarrow 0} \frac{10x}{\sqrt{1+x} - 1}$  ni toping.

Yechilishi. Ikki funksiya nisbatining limiti haqidagi 5-teoremani bu limitini hisoblashda ham bevosita qo'llab bo'lmaydi. Berilgan kasr ifoda maxrajini irratsionallikdan qutqarib, limitni hisoblaymiz:

$$\lim_{x \rightarrow 0} \frac{10x}{\sqrt{1+x}-1} = \lim_{x \rightarrow 0} \frac{10x(\sqrt{1+x}+1)}{(\sqrt{1+x}-1)(\sqrt{1+x}+1)} = \lim_{x \rightarrow 0} \frac{10x(\sqrt{1+x}+1)}{1+x-1} =$$

$$= \lim_{x \rightarrow 0} 10 \cdot (\sqrt{1+x}+1) = 10 \left( \lim_{x \rightarrow 0} \sqrt{1+x}+1 \right) = 10 + 10 = 20.$$

Javob: 20.

8-misol.  $\lim_{x \rightarrow +\infty} \frac{5x^2 - 4x + 6}{x^2 + x + 3}$  ni hisoblang.

Yechilishi. O'zgaruvchi  $x$  cheksiz ortib borsa, berilgan kasr ifodaning surati ham, maxraji ham cheksiz ortadi. Shu sababli bu yerda ham 5-teoremani bevosita qo'llab bo'lmaydi. Biroq kasrning surat va maxrajini  $x^2$ ga bo'lsak, uning qiymati o'zgarmaydi va  $x \rightarrow +\infty$  da limiti mavjud bo'lgan ifoda hosil bo'ladi. Shunday qilib,

$$\lim_{x \rightarrow +\infty} \frac{5x^2 - 4x + 6}{x^2 + x + 3} = \lim_{x \rightarrow +\infty} \frac{5 - \frac{4}{x} + \frac{6}{x^2}}{1 + \frac{1}{x} + \frac{3}{x^2}} = \frac{\lim_{x \rightarrow +\infty} \left( 5 - \frac{4}{x} + \frac{6}{x^2} \right)}{\lim_{x \rightarrow +\infty} \left( 1 + \frac{1}{x} + \frac{3}{x^2} \right)}.$$

Bu yerda  $\lim_{x \rightarrow +\infty} \frac{4}{x}$ ,  $\lim_{x \rightarrow +\infty} \frac{6}{x^2}$ ,  $\lim_{x \rightarrow +\infty} \frac{1}{x}$  va  $\lim_{x \rightarrow +\infty} \frac{3}{x^2}$  lar cheksiz kichik miqdorlar, shu sababli

$$\lim_{x \rightarrow +\infty} \left( 5 - \frac{4}{x} + \frac{6}{x^2} \right) = 5, \quad \lim_{x \rightarrow +\infty} \left( 1 + \frac{1}{x} + \frac{3}{x^2} \right) = 1.$$

Demak,  $\lim_{x \rightarrow +\infty} \frac{5x^2 - 4x + 6}{x^2 + x + 3} = \frac{5}{1} = 5.$

Javob: 5.

## 2-§. Birinchi va ikkinchi ajoyib limitlar

### 2.1. Birinchi ajoyib limit.

**Teorema.**  $y = \frac{\sin x}{x} = 1$  funksiya  $x \rightarrow 0$  da 1 ga teng limitga ega:

$$\lim_{x \rightarrow 0} \frac{\sin x}{x} = 1.$$

Isboti. Birlik aylanada radianlarda ifodalangan  $x$  burchak  $0 < x < \frac{\pi}{2}$  oraliqda yotadi deb faraz qilamiz. ( $\frac{\sin x}{x}$  funksiya juft

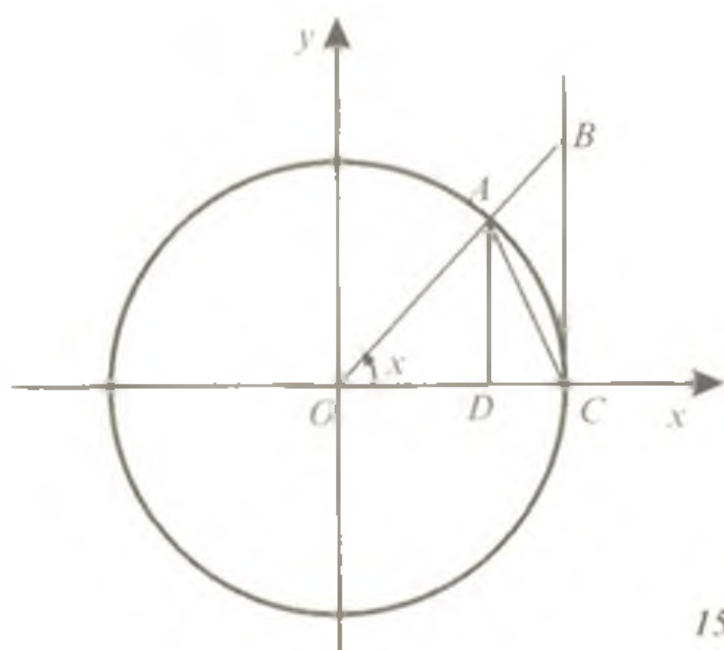

159-rasm

funksiya bo'lganligi sababli  $x > 0$  holni qarash yetarlidir). 159-rasmdagi chizmadan ko'rinib turibdiki,  $OAC$  uchburchak,  $OAC$  sektor va  $OBC$  uchburchak yuzalari uchun

$$S_{\Delta OAC} < S_{\text{sek.}OAC} < S_{\Delta OBC}$$

tengsizlik o'rinli.

$$S_{\Delta OAC} = \frac{1}{2} OA \cdot OC \sin x = \frac{1}{2} \sin x, \quad S_{\text{sek.}OAC} = \frac{1}{2} OA^2 \cdot \overset{\cup}{AC} = \frac{x}{2},$$

$$S_{\Delta OBC} = \frac{1}{2} OC \cdot BC = \frac{1}{2} \operatorname{tg} x \text{ bo'lganligidan,}$$

$$\sin x < x < \operatorname{tg} x$$

tengsizlikka egamiz. Bu tengsizlikni har bir hadini  $\sin x$  ga bo'lamiz. U holda

$$1 < \frac{x}{\sin x} < \frac{1}{\cos x} \Leftrightarrow \cos x < \frac{\sin x}{x} < 1.$$

Shunday qilib,  $\frac{\sin x}{x}$  funksiya 6-teoremaga ko'ra  $\lim_{x \rightarrow 0} \cos x = 1$ ,

$\lim_{x \rightarrow 0} 1 = 1$  bo'lganligi sababli  $x \rightarrow 0$  da 1 ga teng limitga ega:

$$\lim_{x \rightarrow 0} \frac{\sin x}{x} = 1. \quad (1)$$

(1) limit **birinchi ajoyib limit** deb ataladi.

1-misol.  $\lim_{x \rightarrow 0} \frac{\sin 5x}{x}$  ni hisoblang.

Yechilishi.  $\lim_{x \rightarrow 0} \frac{\sin 5x}{x} = \lim_{x \rightarrow 0} \frac{5 \sin 5x}{5x} = 5 \lim_{x \rightarrow 0} \frac{\sin 5x}{5x} = 5 \cdot 1 = 5.$

Javob: 5.

2-misol.  $\lim_{x \rightarrow 0} \frac{\operatorname{tg} x}{x}$  ni hisoblang.

Yechilishi.  $\lim_{x \rightarrow 0} \frac{\operatorname{tg} x}{x} = \lim_{x \rightarrow 0} \frac{\sin x}{x} \cdot \frac{1}{\cos x} = \lim_{x \rightarrow 0} \frac{\sin x}{x} \lim_{x \rightarrow 0} \frac{1}{\cos x} = 1 \cdot 1 = 1.$

Javob: 1.

3-misol.  $\lim_{x \rightarrow 0} \frac{1 - \cos x}{x}$  ni hisoblang.

Yechilishi.

$$\lim_{x \rightarrow 0} \frac{1 - \cos x}{x} = \lim_{x \rightarrow 0} \frac{2 \sin^2 \frac{x}{2}}{x} = \lim_{x \rightarrow 0} \frac{\sin \frac{x}{2}}{\frac{x}{2}} \cdot \lim_{x \rightarrow 0} \sin \frac{x}{2} = 1 \cdot 0 = 0.$$

Javob: 0.

**2.2. Ikkinchi ajoyib limit.  $e$  soni.** Umumiy hadi  $x_n = \left(1 + \frac{1}{n}\right)^n$  ga teng bo'lgan ketma-ketlikni ko'rib chiqamiz. Bu ketma-ketlik monoton o'suvchi va chegaralangan ekanligini ko'rsatamiz.

1)  $(n+1)$  ta  $\underbrace{\left(1 + \frac{1}{n}\right), \left(1 + \frac{1}{n}\right), \dots, \left(1 + \frac{1}{n}\right)}_{n \text{ ta}}$  sonlarning o'rta arif-

metigi va o'rta geometrigi uchun

$$\frac{n \left(1 + \frac{1}{n}\right) + 1}{n+1} > \sqrt[n+1]{\left(1 + \frac{1}{n}\right)^n \cdot 1}$$

tengsizlik o'rinlidir (II bob, 7-§ ga qarang). Bu tengsizlikning chap qismini soddalashtirib, so'ngra har ikkala qismini  $(n+1)$  darajaga ko'tarib, ushbu

$$\left(1 + \frac{1}{n+1}\right)^{n+1} > \left(1 + \frac{1}{n}\right)^n$$

tengsizlikka ega bo'lamiz. Bundan  $x_{n+1} > x_n$ . Shu bilan ko'rilayotgan ketma-ketlik monoton o'suvchi ekanligi isbotlandi.

2) Endi qaralayotgan ketma-ketlikning chegaralangan ekanligini ko'rsatamiz. Buning uchun umumiy hadi  $a_n = \left(1 - \frac{1}{n}\right)^n$  ga teng

bo'lgan ketma-ketlikni ko'rib chiqamiz.  $\{x_n\}$  ketma-ketlikning monotonligini isbotlaganimizga o'xshash  $\{a_n\}$  ketma-ketlikning monotonligini isbotlash mumkin:

$a_{n+1} > a_n.$

$\{x_n\}$  va  $\{a_n\}$  ketma-ketliklar umumiy hadlari ko'paytmasi

$$x_n \cdot a_n = \left(1 + \frac{1}{n}\right)^n \left(1 - \frac{1}{n}\right)^n = \left(1 - \frac{1}{n^2}\right)^n < 1.$$

Shunga ko'ra barcha  $n > 1$  lar uchun

$$x_n < \frac{1}{a_n}.$$

$\{a_n\}$  ketma-ketlik monoton o'suvchi ekanligi sababli uning barcha hadlari, uchinchisidan boshlab, ikkinchi hadidan katta. Shunga ko'ra barcha  $n \geq 3$  uchun

$$a_n > a_2; a_n > \left(1 - \frac{1}{2}\right)^2 \Rightarrow a_n > \frac{1}{4}.$$

Demak, barcha  $n \geq 3$  uchun  $x_n < \frac{1}{a_n} < 4$ . Bu tengsizlik  $n = 1, n = 2$  bo'lganda ham to'g'ridir. Shu sababli barcha natural  $n$  uchun

$$0 < \left(1 + \frac{1}{n}\right)^n < 4.$$

Shu bilan  $\{x_n\}$  ketma-ketlikning chegaralanganligi isbotlandi. Bu ketma-ketlik monoton va chegaralangan bo'lganligi uchun uning limiti mavjud. Bu limitni  $e$  harfi bilan belgilash qabul qilingan:

$$\lim_{n \rightarrow \infty} \left(1 + \frac{1}{n}\right)^n = e. \quad (2)$$

$e = 2.718218284\dots$  – irratsional sonidir. (2) limit ko'pgina matematik tekshirishlarning asosida yotadigan ajoyib limitlardan biri bo'lib, u **ikkinchi ajoyib limit** deb ataladi.

$\lim_{\alpha \rightarrow +\infty} \left(1 + \frac{1}{\alpha}\right)^\alpha = e$  ekanligini eslatib o'tamiz.

4-misol.  $\lim_{x \rightarrow +\infty} \left(1 + \frac{1}{x}\right)^{3x}$  ni hisoblang.

Yechilishi.

$$\lim_{x \rightarrow +\infty} \left(1 + \frac{1}{x}\right)^{3x} = \lim_{x \rightarrow +\infty} \left[\left(1 + \frac{1}{x}\right)^x\right]^3 = \left(\lim_{x \rightarrow +\infty} \left(1 + \frac{1}{x}\right)^x\right)^3 = e^3.$$

Javob:  $e^3$ .

5-misol.  $\lim_{x \rightarrow +\infty} 2 \left(1 + \frac{1}{x^2}\right)^x$  ni hisoblang.

Yechilishi.  $\lim_{x \rightarrow +\infty} 2 \left(1 + \frac{1}{x^2}\right)^x = 2 \lim_{x \rightarrow +\infty} \left( \left(1 + \frac{1}{x^2}\right)^{x^2} \right)^{\frac{1}{x}} = 2e^0 = 2 \cdot 1 = 2$ .

Javob: 2.

### 3-§. Funksiyaning uzluksizligi

**3.1. Funksiyaning nuqtada va oraliqda uzluksizligi. Ta'rif.** Agar  $y = f(x)$  funksiya  $x_0$  nuqtada va uning biror atrofida aniqlangan bo'lib, funksiyaning  $x_0$  nuqtadagi limiti uning shu nuqtadagi qiymatiga teng, ya'ni

$$\lim_{x \rightarrow x_0} f(x) = f(x_0)$$

bo'lsa, bu funksiya  $x_0$  nuqtada uzluksiz deyiladi.

Agar funksiya  $f$  oraliqning har bir nuqtasida uzluksiz bo'lsa, u holda bu funksiya shu oraliqda uzluksiz deyiladi. Bunda  $f$  oraliq  $f(x)$  funksiyaning uzluksizlik oralig'i deyiladi. Har qanday ratsional funksiya o'zi aniqlangan nuqtalarning hammasida uzluksizdir.

**Ta'rif.** Agar funksiya  $x_0$  nuqtaning biror atrofida aniqlangan bo'lib,  $x_0$  nuqtaning o'zida aniqlanmagan bo'lsa yoki uning  $x_0$  nuqtadagi limiti funksiyaning shu nuqtadagi qiymatiga teng bo'lmasa, funksiya  $x_0$  nuqtada uzilishga ega deyiladi,  $x_0$  nuqta esa funksiyaning uzilish nuqtasi deyiladi.

Masalan,  $y = \frac{k}{x}$  funksiya  $x = 0$  dan boshqa barcha nuqtalarda aniqlangan,  $x = 0$  nuqtada esa uzilishga ega.

#### 3.2. Nuqtada uzluksiz funksiyalarning xossalari.

1. Agar  $f(x)$  va  $\varphi(x)$  funksiyalar  $x_0$  nuqtada uzluksiz bo'lsa, u holda  $f(x) \pm \varphi(x)$  funksiya ham  $x_0$  nuqtada uzluksiz funksiyadir.

2. Agar  $f(x)$  va  $\varphi(x)$  funksiyalar  $x_0$  nuqtada uzluksiz bo'lsa, u holda  $f(x) \cdot \varphi(x)$  ko'paytma ham  $x_0$  nuqtada uzluksiz funksiyadir.

3. Agar  $f(x)$  va  $\varphi(x)$  funksiyalar  $x_0$  nuqtada uzluksiz bo'lib,  $\varphi(x_0) \neq 0$  bo'lsa, u holda ularning bo'linmasi  $\frac{f(x)}{\varphi(x)}$  ham  $x_0$  nuqtada uzluksiz bo'ladi.



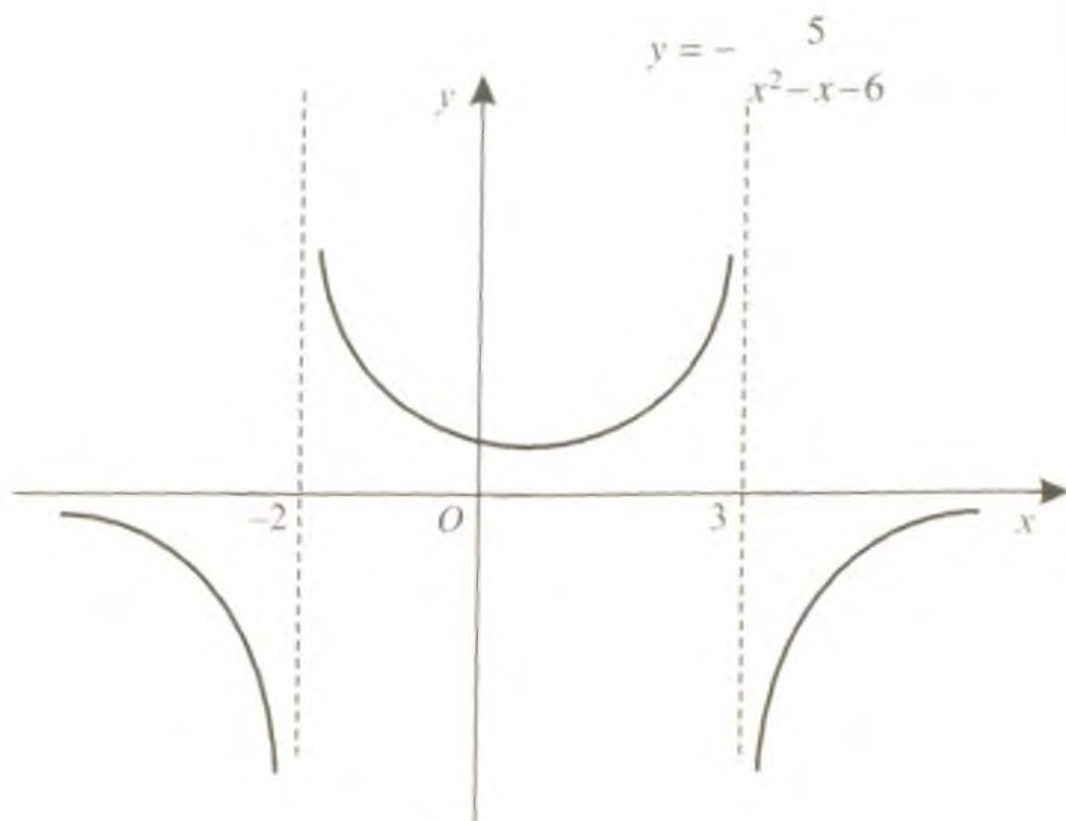

160-rasm

1-misol.  $y = -\frac{5}{x^2 - x - 6}$  funksiyaning uzluksizlik oraliqlarini toping.

Yechilishi. Berilgan ratsional funksiyaning aniqlanish sohasi  $(-\infty; -2) \cup (-2; 3) \cup (3; +\infty)$  oraliqlar birlashmasidan iborat. Demak, bu funksiya shu oraliqlarning barcha nuqtalarida uzluksiz bo'lib,  $x = -2$  va  $x = 3$  nuqtalarda uzilishga ega (160-rasm).

Javob:  $(-\infty; -2) \cup (-2; 3) \cup (3; +\infty)$ .

2-misol.  $f(x) = \begin{cases} x+2, & x > 0, \\ x-1, & x \leq 0 \end{cases}$  funksiyaning uzilish nuqtasini va

shu nuqtadagi qiymatini toping.

Yechilishi. Berilgan funksiya  $x = 0$  nuqtada uzilishga ega, chunki  $x$  nolga intilganda uning limiti mavjud emas (161-rasm). Funksiyaning uzilish nuqtasidagi qiymati  $f(0) = 0 - 1 = -1$  ga teng.

Javob: 0; -1.

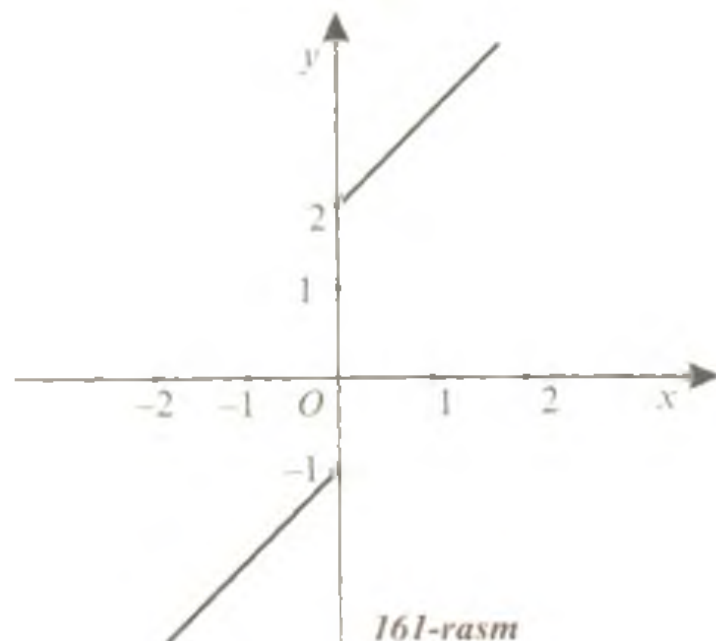

#### 4-§. Erkli o'zgaruvchi va funksiya orttirmasi

$y = f(x)$  funksiya  $I$  oraliqda aniqlangan.  $x_0$  va  $x$  esa erkli o'zgaruvchining shu oraliqqa tegishli ikki qiymati bo'lsin; u holda  $x - x_0$  ayirma **erkli o'zgaruvchining** (yoki **argumentning**) **orttirmasi** deyiladi va  $\Delta x$  kabi belgilanadi. Shunday qilib,

$$\Delta x = x - x_0. \quad (1)$$

(1) dan  $x = x_0 + \Delta x$ . Bu tenglik erkli o'zgaruvchining dastlabki qiymati  $\Delta x$  orttirma olganligini anglatadi. Bunda funksiyaning qiymati mos ravishda

$$f(x) - f(x_0) = f(x_0 + \Delta x) - f(x_0) \quad (2)$$

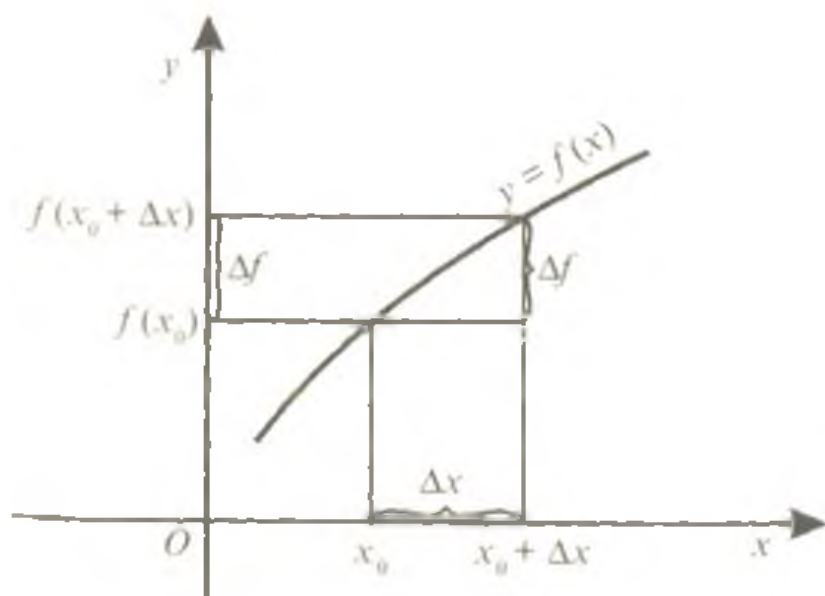

162-rasm

miqdorga o'zgaradi. (2) tenglikdagi funksiyaning  $f(x_0 + \Delta x)$  yangi qiymati bilan uning boshlang'ich qiymati  $f(x_0)$  orasidagi ayirma **funksiyaning  $x_0$  nuqtadagi orttirmasi** deyiladi va  $\Delta f(x_0)$  belgi bilan belgilanadi (162-rasm). Shunday qilib,

$$\Delta f(x_0) = f(x_0 + \Delta x) - f(x_0) \quad (3)$$

Funksiyaning berilgan  $x_0$  nuqtadagi orttirmasi qisqacha  $\Delta f$  yoki  $\Delta y$  orqali belgilanadi.

(3) munosabatdan  $\Delta f$  orttirma  $x_0$  ga ham,  $\Delta x$  ga ham bog'liq ekanligi ko'rinib turibdi. Tayin  $x_0$  da esa  $\Delta f$  orttirma  $\Delta x$  ning funksiyasi bo'lib, u argument  $\Delta x$  ga o'zgarganda funksiya qanchaga o'zgarганиni ko'rsatadi.

1-misol. Agar  $x_0 = 1$ ,  $x = 3$  bo'lsa,  $y = x^3$  funksiya orttirmasini toping.

Yechilishi.

$$\Delta y = y(x_0 + \Delta x) - y(x_0) = y(3) - y(1) = 3^3 - 1^3 = 27 - 1 = 26.$$

Javob: 26.

2-misol. Agar  $x_0 = 2$ ,  $\Delta x = 0,2$  bo'lsa,  $y = x^2 - 2x + 1$  funksiyaning orttirmasini toping.

Yechilishi. Funksiya orttirmasini topamiz:

$$\begin{aligned} \Delta y &= y(x_0 + \Delta x) - y(x_0) = (x_0 + \Delta x)^2 - 2(x_0 + \Delta x) + 1 - x_0^2 + 2x_0 - 1 = \\ &= x_0^2 + 2x_0\Delta x + \Delta x^2 - 2x_0 - 2\Delta x + 1 - x_0^2 + 2x_0 - 1 = \Delta x^2 + 2x_0\Delta x - \\ &- 2\Delta x = (0,2)^2 + 2 \cdot 2 \cdot 0,2 - 2 \cdot 0,2 = 0,04 + 0,8 - 0,4 = 0,44. \end{aligned}$$

Javob: 0,44.

## 5-§. Hosila

### 5.1. Hosilaning ta'rifi.

**Ta'rif.** Funksiyani  $x_0$  nuqtadagi orttirmasi  $\Delta y$  ning argument orttirmasi  $\Delta x$  ga nisbatining  $\Delta x$  nolga intilgandagi limiti  $y = f(x)$  funksiyaning  $x_0$  nuqtadagi hosilasi deb ataladi.

Bu limit  $y'$ ,  $f'(x_0)$ ,  $\frac{dy}{dx}$ ,  $\frac{df}{dx}$  belgilardan biri bilan belgilanadi. Shunday qilib,

$$f'(x_0) = \lim_{\Delta x \rightarrow 0} \frac{\Delta y}{\Delta x} = \lim_{\Delta x \rightarrow 0} \frac{f(x_0 + \Delta x) - f(x_0)}{\Delta x}.$$

Berilgan funksiyaning hosilasini topish **differensiallash** deyiladi, hosilaga ega bo'lgan funksiya esa **differensiallanuvchi funksiya** deyiladi.

Hosilaning ta'rifidan funksiya  $x_0$  nuqtada va uning biror atrofida aniqlangan bo'lsagina hosilaga ega bo'lishi mumkinligi kelib chiqadi. Berilgan nuqtada funksiyaning uzluksiz bo'lishi uning shu nuqtada hosilaga ega bo'lishining **zaruriy sharti** hisoblanadi. Ammo teskari tasdiq o'rinli emas. Masalan,  $f(x) = |x - 1|$  funksiya  $(-\infty; +\infty)$  da uzluksiz, lekin  $x_0 = 1$  nuqtada hosilaga ega emas. Haqiqatan ham,

$$\lim_{\Delta x \rightarrow +\infty} \frac{\Delta f(x_0)}{\Delta x} = \begin{cases} 1, & \text{agar } \Delta x > 0, \\ -1, & \text{agar } \Delta x < 0, \end{cases}$$

bo'lib, bu funksiyaning  $\Delta x \rightarrow 0$  da limiti mavjud emas.

**Ta'rif.** Agar  $y = f(x)$  funksiya  $l$  oraliqning har bir nuqtasida hosilaga ega bo'lsa, u shu oraliqda differensiallanuvchi deb ataladi.

1-misol.  $y = x$  funksiyaning hosilasini toping.

**Yechilishi.** Funksiya argumentiga biror  $x$  nuqtada  $\Delta x$  orttirma beramiz. U holda funksiya shu nuqtada

$$\Delta y = f(x + \Delta x) - f(x) = (x + \Delta x) - x = \Delta x$$

orttirma oladi.

Funksiya orttirmasining argument orttirmasi  $\Delta x$  ga nisbatining  $\Delta x$  nolga intilgandagi limitini topamiz:

$$y' = \lim_{\Delta x \rightarrow 0} \frac{\Delta y}{\Delta x} = \lim_{\Delta x \rightarrow 0} \frac{\Delta x}{\Delta x} = 1;$$

Javob: 1.

2-misol.  $y = x^2$  funksiyaning hosilasini toping.

**Yechilishi.** Funksiya argumentining biror  $x$  nuqtadagi  $\Delta x$  orttirmasiga mos keluvchi funksiyaning orttirmasini topamiz:

$$\Delta y = f(x + \Delta x) - f(x) = (x + \Delta x)^2 - x^2 = x^2 + 2x\Delta x + (\Delta x)^2 - x^2 = 2x\Delta x + (\Delta x)^2.$$

Funksiya orttirmasining argument orttirmasiga nisbatining  $\Delta x$  nolga intilgandagi limitini topamiz:

$$y' = \lim_{\Delta x \rightarrow 0} \frac{\Delta y}{\Delta x} = \lim_{\Delta x \rightarrow 0} \frac{2x\Delta x + (\Delta x)^2}{\Delta x} = \lim_{\Delta x \rightarrow 0} (2x + \Delta x) = 2x.$$

Javob:  $2x$ .

3-misol.  $y = \frac{1}{x}$  funksiyaning hosilasini toping.

**Yechilishi.** Berilgan funksiya  $x = 0$  dan boshqa barcha nuqtalarida aniqlangan. Funksiyaning aniqlanish sohasiga tegishli biror  $x$  nuqtada argumentga  $\Delta x$  orttirma berib, shu orttirmaga mos keluvchi funksiya orttirmasini topamiz:

$$\Delta y = \frac{1}{x+\Delta x} - \frac{1}{x} = \frac{x-x-\Delta x}{x(x+\Delta x)} = -\frac{\Delta x}{x(x+\Delta x)}.$$

$\frac{\Delta y}{\Delta x}$  nisbatning  $\Delta x \rightarrow 0$  dagi limitini hisoblaymiz:

$$y' = \lim_{\Delta x \rightarrow 0} \frac{\Delta y}{\Delta x} = -\lim_{\Delta x \rightarrow 0} \frac{\Delta x}{\Delta x \cdot x(x+\Delta x)} = -\lim_{\Delta x \rightarrow 0} \frac{1}{x(x+\Delta x)} = -\frac{1}{x^2}.$$

Javob:  $-\frac{1}{x^2}$ .

4-misol. O'zgarmasning hosilasi nolga teng ekanligini isbotlang. Isboti.  $x$  argument  $\Delta x$  orttirma olganda funksiya ushbu orttirmani oladi:

$$\Delta y = f(x + \Delta x) - f(x) = C - C = 0.$$

Demak,

$$y' = \lim_{\Delta x \rightarrow 0} \frac{\Delta y}{\Delta x} = 0.$$

Shunday qilib,  $y = C$  ( $C$  - const) bo'lsa,  $y' = 0$  yoki  $C' = 0$ .

5-misol.  $y = \sqrt{x}$ , ( $x > 0$ ) funksiyaning hosilasini toping.

Yechilishi. Hosilaning ta'rifiga ko'ra funksiya orttirmasini argument orttirmasiga nisbatining  $\Delta x \rightarrow 0$  dagi limitini topamiz:

$$\begin{aligned} y' &= \lim_{\Delta x \rightarrow 0} \frac{\Delta y}{\Delta x} = \lim_{\Delta x \rightarrow 0} \frac{\sqrt{x+\Delta x} - \sqrt{x}}{\Delta x} = \lim_{\Delta x \rightarrow 0} \frac{(\sqrt{x+\Delta x} - \sqrt{x})(\sqrt{x+\Delta x} + \sqrt{x})}{\Delta x(\sqrt{x+\Delta x} + \sqrt{x})} = \\ &= \lim_{\Delta x \rightarrow 0} \frac{x+\Delta x - x}{\Delta x(\sqrt{x+\Delta x} + \sqrt{x})} = \lim_{\Delta x \rightarrow 0} \frac{1}{\sqrt{x+\Delta x} + \sqrt{x}} = \frac{1}{\sqrt{x+0} + \sqrt{x}} = \frac{1}{2\sqrt{x}}. \end{aligned}$$

Javob:  $\frac{1}{2\sqrt{x}}$ .

**5.2. Differensiallashning asosiy qoidalari.** Hosilani hisoblashda quyidagi differensiallash qoidalaridan foydalaniladi:

1. Ikki  $u(x)$  va  $v(x)$  funksiyalar biror oraliqda aniqlangan bo'lib, shu oraliqqa tegishli  $x$  nuqtada differensiallanuvchi bo'lsa, u holda ularning algebraik yig'indisi ham shu nuqtada differensiallanuvchi bo'ladi va

$$(u(x) \pm v(x))' = u'(x) \pm v'(x). \quad (1)$$

(1) formula qo'shiluvchilar soni istalgan chekli son bo'lganda ham o'rinlidir.

$$(u_1 + u_2 + \dots + u_n)' = u_1' + u_2' + \dots + u_n'$$

2. Differensiallanuvchi ikki  $u$  va  $v$  funksiyalar ko'paytmasining hosilasi

$$(uv)' = u'v + v'u \quad (2)$$

formula bilan topiladi.

3. O'zgarmas ko'paytuvchi hosila belgisidan tashqariga chiqarilishi mumkin:

$$(cf(x))' = cf'(x). \quad (3)$$

4. Agar  $u$  va  $v$  funksiyalar  $x$  nuqtada differensiallanuvchi bo'lib,  $v(x) \neq 0$  bo'lsa,  $u$  holda  $\frac{u}{v}$  bo'linma ham differensiallanuvchi bo'ladi va uning hosilasi

$$\left(\frac{u}{v}\right)' = \frac{u'v - uv'}{v^2} \quad (4)$$

formula bilan topiladi.

6-misol.  $2x^2 - 3x + \sqrt{x} + 10$  funksiyaning hosilasini toping.

Yechilishi. Berilgan funksiya hosilasini topishda 1, 2, 4 va 5 misollar yechimlaridan hamda differensiallashning 1, 3-qoidalaridan foydalanamiz:

$$(2x^2 - 3x + \sqrt{x} + 10)' = (2x^2)' - (3x)' + (\sqrt{x})' + (10)' = 2(x^2)' - 3(x)' + (\sqrt{x})' + 0 = 2 \cdot 2x - 3 \cdot 1 + \frac{1}{2\sqrt{x}} = 4x + \frac{1}{2\sqrt{x}} - 3.$$

Javob:  $4x + \frac{1}{2\sqrt{x}} - 3.$

7-misol.  $y = x^3$  funksiyaning hosilasini toping.

Yechilishi.  $x^3 = x^2 \cdot x$  deb, differensiallashning ko'paytma uchun formulasi (2) dan foydalanamiz.

$$y' = (x^2 \cdot x)' = (x^2)' \cdot x + x' \cdot x^2 = 2x \cdot x + 1 \cdot x^2 = 2x^2 + x^2 = 3x^2.$$

Javob:  $3x^2.$

8-misol.  $y = \frac{x-1}{\sqrt{x}}$  funksiyaning hosilasini toping.

Yechilishi. Differensiallashning bo'linma uchun qoidasidan foydalanamiz:

$$y' = \left(\frac{x-1}{\sqrt{x}}\right)' = \frac{(x-1)' \cdot \sqrt{x} - (x-1) \cdot (\sqrt{x})'}{(\sqrt{x})^2} = \frac{(1-0)\sqrt{x} - (x-1) \cdot \frac{1}{2\sqrt{x}}}{x} = \frac{2x - x + 1}{2x \cdot \sqrt{x}} = \frac{x+1}{2x\sqrt{x}}.$$

Javob:  $\frac{x+1}{2x\sqrt{x}}.$

**5.3. Darajali funksiyaning hosilasi.** Hosila ta'rifidan va differensiallash qoidalaridan foydalanib

$$(c)' = 0; (x)' = 1; (x^2)' = 2x; (x^3)' = 3x^2; \left(\frac{1}{x}\right)' = -\frac{1}{x^2} \quad (x \neq 0);$$

$(\sqrt{x})' = \frac{1}{2\sqrt{x}} \quad (x > 0)$  larni hosil qildik. Bunda  $y = x$ ,  $y = x^2$

$y = x^3$ ,  $y = \frac{1}{x} = x^{-1}$ ,  $y = \sqrt{x} = x^{\frac{1}{2}}$  funksiyalarning hosilalari

$y = x^p$  darajali funksiyaning  $p$  daraja ko'rsatkichi 1, 2, 3; -1 va  $\frac{1}{2}$  larga teng bo'lgan holdagi hosilalaridir. Umuman, istalgan **haqiqiy ko'rsatkichli darajali funksiyaning hosilasi**

$$(x^p)' = p \cdot x^{p-1} \quad (5)$$

**formula bilan topiladi.** Bu formula  $x$  ning (5) formulaning o'ng qismi ma'noga ega bo'ladigan qiymatlarida o'rinli.

9-misol.  $y = \frac{1}{4}x^4 + x\sqrt{x}$  bo'lsa,  $y'$  (4) ni hisoblang.

Yechilishi.  $x\sqrt{x} = x^{\frac{3}{2}}$  ekanligini hisobga olib, (5) formuladan foydalanamiz:

$$y' = \frac{1}{4}(x^4)' + (x^{\frac{3}{2}})' = \frac{1}{4} \cdot 4x^{4-1} + \frac{3}{2}x^{\frac{3}{2}-1} = x^3 + \frac{3}{2}x^{\frac{1}{2}} = x^3 + \frac{3}{2}\sqrt{x}.$$

Endi, hosilaning  $x = 4$  nuqtadagi qiymatini hisoblaymiz:

$$y'(4) = 4^3 + \frac{3}{2}\sqrt{4} = 64 + 3 = 67.$$

Javob: 67.

**5.4. Murakkab funksiyaning hosilasi.** Agar  $y$  o'zgaruvchi  $u$  ning funksiyasi bo'lib, ya'ni  $y = f(u)$ ,  $u$  esa o'z navbatida  $x$  argumentning funksiyasi bo'lsa, ya'ni  $u = \varphi(x)$  bo'lsa,  $u$  holda o'zgaruvchi  $y$  o'zgaruvchi  $x$  ga **oraliq argument**  $u$  orqali bog'liq deyilib,  $x$  ning **murakkab funksiyasi** deyiladi (funksiyadan funksiya) va  $y = f(\varphi(x))$  kabi yoziladi.

**Teorema.** Agar  $y = f(u)$  va  $u = \varphi(x)$  funksiyalar differensiallanuvchi funksiyalar bo'lsa, murakkab  $y = f(\varphi(x))$  funksiyaning erkli o'zgaruvchi  $x$  bo'yicha hosilasi bu funksiyaning oraliq argumenti bo'yicha hosilasining oraliq argumentning erkli o'zgaruvchi  $x$  bo'yicha hosilasiga ko'paytmasiga teng, ya'ni

$$y'_x = y'_u \cdot u'_x \quad (6)$$

10-misol.  $y = (kx + b)^n$  funksiyaning hosilasini toping.

Yechilishi.  $y = u^n$ ;  $u = kx + b$  deb, (6) formuladan foydalanamiz:

$$y' = (u^n)' \cdot n' = nu^{n-1} \cdot u' = n(kx + b)^{n-1} \cdot k = nk(kx + b)^{n-1}.$$

Javob:  $nk(kx + b)^{n-1}$ .

11-misol.  $y = \sqrt[3]{7x^2 + 5x - 3}$  funksiyaning hosilasini toping.

Yechilishi.  $y = \sqrt[3]{u}$ ;  $u = 7x^2 + 5x - 3$ .

$$y' = \left(u^{\frac{1}{3}}\right)' \cdot u' = \frac{1}{3}u^{-\frac{2}{3}} \cdot (7x^2 + 5x - 3)' = \frac{1}{3\sqrt[3]{u^2}} \cdot (14x + 5) =$$

$$= \frac{14x + 5}{3\sqrt[3]{(7x^2 + 5x - 3)^2}}.$$

Javob:  $\frac{14x + 5}{3\sqrt[3]{(7x^2 + 5x - 3)^2}}$ .

Differensiallash borasida tajriba ortgan sari oraliq argumentni maxsus belgilab olishga zaruriyat qolmaydi.

## 6-§. Hosilaning geometrik va fizik ma'nolari

**6.1. Hosilaning geometrik ma'nosi.** Biror  $[a; b]$  oraliqda aniqlangan  $y = f(x)$  funksiya berilgan bo'lsin. Uning grafigiga tegishli  $M(x_0; y_0)$  va  $N(x_0 + \Delta x; y_0 + \Delta y)$  nuqtalarni olamiz (163-rasm). Egri chiziqning ikki nuqtasini tutashtiruvchi to'g'ri chiziq **kesuvchi** deb ataladi. Agar  $M$  nuqta qo'zg'almas,  $N$  nuqta esa grafik bo'ylab harakatlanib,  $M$  nuqtaga yaqinlashsa, u holda  $MN$  kesuvchi  $M$  nuqta atrofida burilib biror  $MT$  limit to'g'ri chiziqqa yaqinlashadi. Bu  $MT$  to'g'ri chiziq  $y = f(x)$  funksiyaga  $M$  nuqtada o'tkazilgan **urinma** deb ataladi. 163-rasmdagi chizmada  $MT$  urinma  $Ox$  o'qi bilan  $\alpha$  burchak,  $MN$  kesuvchi esa  $\beta$  burchak tashkil qiladi.  $MNK$  to'g'ri burchakli uchburchakda

$$\operatorname{tg} \beta = \frac{\Delta y}{\Delta x}.$$

$y = f(x)$  funksiya grafigi bo'ylab  $N \rightarrow M$  da  $\Delta x \rightarrow 0$  bo'ladi va  $\beta \rightarrow \alpha$ . Bu holatni quyidagicha yozish mumkin:



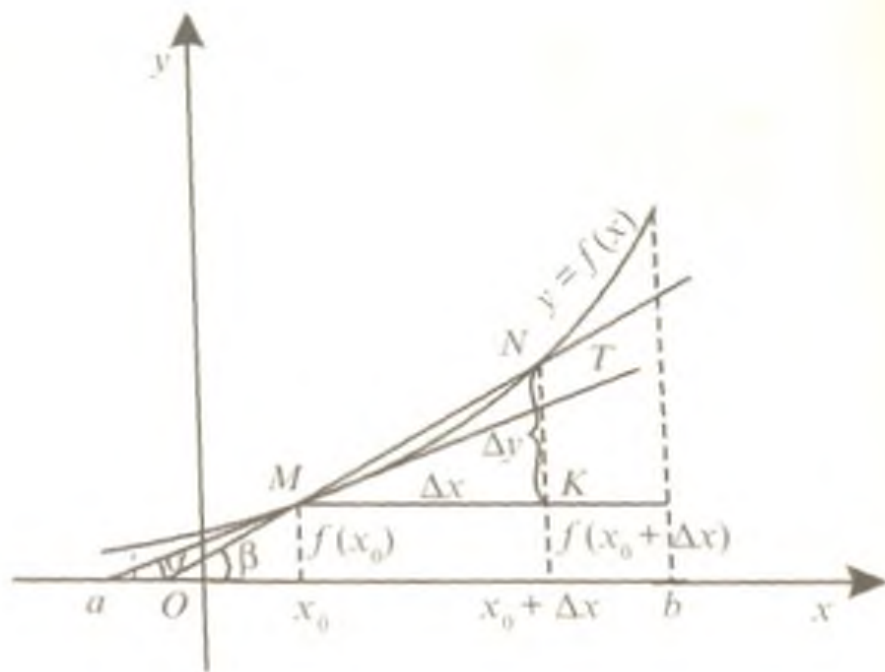

163-rasm

$$\lim_{\Delta x \rightarrow 0} \operatorname{tg} \beta = \lim_{\Delta x \rightarrow 0} \frac{\Delta y}{\Delta x}.$$

Shunday qilib,

$$\operatorname{tg} \alpha = f'(x_0). \quad (1)$$

$y = kx + b$  chiziqli funksiyaning grafigi to'g'ri chiziq ekanligini eslatib o'tamiz. Bunda  $k = \operatorname{tg} \alpha$  son to'g'ri chiziqning burchak ko'effitsiyenti,  $\alpha$  burchak esa shu to'g'ri chiziq bilan  $Ox$  o'qi orasidagi burchak deb ataladi.

Demak,  $y = f(x)$  funksiyaning  $x_0$  nuqtadagi hosilasi funksiya grafigiga  $x_0$  abssissali  $M$  nuqtada o'tkazilgan  $MT$  urinmaning  $Ox$  o'qining musbat yo'nalishi bilan hosil qilgan burchagining tangensiga, ya'ni urinmaning burchak ko'effitsiyentiga teng. Hosilaning geometrik ma'nosi ana shundan iborat.

1-masala.  $y = x^3$  funksiya grafigiga (1;1) nuqtada o'tkazilgan urinmaning  $Ox$  o'qining musbat yo'nalishi bilan hosil qilgan burchagini toping.

Yechilishi.  $y' = (x^3)' = 3x^2$ . (1) formulaga ko'ra  $\operatorname{tg} \alpha = y'(1) = 3 \cdot 1 = 3$ . Bundan

$$\alpha = \operatorname{arctg} 3.$$

Javob:  $\operatorname{arctg} 3$ .

2-masala.  $y = \frac{1}{3}x^3 + \frac{1}{2}x^2 - 6x$  funksiyaning grafigiga o'tkazilgan urinma erkli o'zgaruvchi  $x$  ning qanday qiymatlarida  $y = 6x - 1$  to'g'ri chiziqqa parallel bo'ladi?

Yechilishi. Funksiya grafigiga o'tkazilgan urinma tenglamasini  $y = k_1x + b_1$  ko'rinishda yozish mumkin, bunda

$$k_1 = \operatorname{tg} \alpha = y'(x) = \left( \frac{1}{3}x^3 + \frac{1}{2}x^2 - 6x \right)' = x^2 + x - 6.$$

Berilgan  $y = 6x - 1$  to'g'ri chiziqning burchak koeffitsiyenti 6 ga teng:  $k_2 = 6$ .

Ikki to'g'ri chiziqning parallellik sharti  $k_1 = k_2$  tenglikdan foydalanib,

$$x^2 + x - 6 = 6$$

tenglamaga ega bo'lamiz. Bu tenglamaning ildizlari  $x_1 = -4$  va  $x_2 = 3$  qo'yilgan masalaning yechimlari bo'ladi.

Javob:  $-4$  va  $3$ .

**6.2. Urinma tenglamasi.** Differrensiallanuvchi  $y = f(x)$  funksiya grafigiga  $(x_0; f(x_0))$  nuqtada o'tkazilgan urinmaning tenglamasini keltirib chiqaramiz.

Urinma tenglamasi  $y = kx + b$  ko'rinishda bo'lsin. U holda (1) formulaga ko'ra  $k = \operatorname{tg} \alpha = f'(x_0)$  bo'lib, urinma tenglamasi  $y = f'(x_0)x + b$  ko'rinishga ega bo'ladi. Urinma  $(x_0; f(x_0))$  nuqtada o'tkazilganligi sababli bu tenglamaga nuqtaning koordinatalarini qo'yib,  $y = f'(x_0) \cdot x + b$  ga ega bo'lamiz. Bundan  $b = f(x_0) - f'(x_0) \cdot x_0$ . Shunday qilib urinmaning tenglamasi  $y = f'(x_0) \cdot x + f(x_0) - f'(x_0) \cdot x_0$  yoki

$$y = f(x_0) + f'(x_0)(x - x_0). \quad (2)$$

3-masala.  $f(x) = x - 3x^2$  funksiya grafigiga  $x_0 = 2$  absissali nuqtada o'tkazilgan urinmaning tenglamasini yozing.

Yechilishi. Berilgan funksiyaning va uning hosilasining  $x_0 = 2$  nuqtadagi qiymatlarini topamiz:

$$f(2) = 2 - 3 \cdot 2^2 = -10;$$

$$f'(2) = (1 - 6x)_{x=2} = 1 - 12 = -11.$$

Topilgan qiymatlarni (2) formulaga qo'yib, urinma tenglamasini hosil qilamiz:

$$y = -10 - 11(x - 2) = -11x + 12.$$

Javob:  $y = -11x + 12$ .

4-masala.  $y = e^{2-x} \cdot \cos \frac{\pi x}{2}$  funksiya grafigiga absissasi  $x_0 = 2$  bo'lgan nuqtada o'tkazilgan urinma tenglamasini toping.

Yechilishi:

$$f(2) = e^{2-2} \cdot \cos \frac{\pi \cdot 2}{2} = e^0 \cdot \cos \pi = -1.$$

$$f'(2) = \left( (2-x)' e^{2-x} \cdot \cos \frac{\pi x}{2} - e^{2-x} \cdot \left( \frac{\pi x}{2} \right)' \sin \frac{\pi x}{2} \right)_{x=2} =$$

$$= -e^{2-2} \cdot \cos \frac{\pi \cdot 2}{2} - e^{2-2} \cdot \frac{\pi}{2} \sin \frac{\pi \cdot 2}{2} = -1 \cdot (-1) - 1 \cdot \frac{\pi}{2} \cdot 0 = 1.$$

Funksiyaning va hosilasining topilgan qiymatlarini (2) formula-ga qo'yamiz:

$$y = -1 + (x-2) = x-3.$$

Javob:  $y = x-3$ .

**6.3. Hosilaning mexanik ma'nosi.** Biror  $M$  moddiy nuqta to'g'ri chiziq bo'ylab harakatlanayotgan bo'lsin (164-rasm).  $M_0$  boshlang'ich vaziyatdan  $M$  nuqttagacha bo'lgan  $s$  masofa  $t$  vaqtga



164-rasm

bog'liq, ya'ni  $s = f(t)$ . Vaqtning biror  $t$  momentida  $M$  moddiy nuqta  $M_0$  boshlang'ich vaziyatdan  $s$  masofada, navbatdagi biror  $t + \Delta t$  momentda esa  $N$  vaziyatda, ya'ni boshlang'ich  $M_0$  vaziyatdan  $s + \Delta s$  masofada bo'lsin. Shunday qilib, moddiy nuqta  $\Delta t$  vaqt oralig'ida  $\Delta s$  masofani bosib o'tadi va  $s$  kattalik  $\Delta s$  ga o'zgaradi.

Moddiy nuqtaning  $\Delta t$  vaqt oralig'idagi o'rtacha tezligi  $v_{\text{ort}} = \frac{\Delta s}{\Delta t}$  tenglik bilan aniqlanishi fizika kursidan ma'lum. Biroq

$$\lim_{\Delta t \rightarrow 0} v_{\text{ort}} = v$$

berilgan  $t$  momentdagi oniy tezlik bo'lib,

$$\lim_{\Delta t \rightarrow 0} \frac{\Delta s}{\Delta t} = s'(t)$$

esa hosila. Shunday qilib,

$$v = s'(t). \quad (3)$$

Hosilaning mexanik ma'nosi shundan iborat va qisqacha bunday deyiladi: **tezlik yo'ldan vaqt bo'yicha olingan hosiladir.**

Harakatning tezlanishi haqida ham shunga o'xshash fikrni aytish mumkin. Moddiy nuqtaning  $v$  tezligi  $t$  vaqtning funksiyasi, ya'ni  $v = v(t)$ . Bu funksiyaning hosilasi esa harakatning tezlanishi deyiladi:

$$a = v'(t). \quad (4)$$

Shunday qilib, **tezlanish tezlikdan vaqt bo'yicha olingan hosiladir** (yoki yo'ldan vaqt bo'yicha olingan ikkinchi hosila tezlanishdir:  $a = s''(t) = (s'(t))'$ ).

5-masala. To'g'ri chiziq bo'ylab  $s(t) = -t^3 + 6t^2 + 15t$  qonuniyat bilan harakatlanayotgan moddiy nuqta harakat boshlangandan necha sekund o'tgach to'xtaydi?

**Yechilishi.** (3) formula bo'yicha harakat tezligini aniqlaymiz.

$$v(t) = (-t^3 + 6t^2 + 15t)' = (-3t^2 + 12t + 15) \text{ m/s.}$$

Moddiy nuqta harakatdan to'xtasa, uning tezligi nolga teng bo'lishi ravshan. Shu sababli

$$-3t^2 + 12t + 15 = 0 \Leftrightarrow t^2 - 4t - 5 = 0 \Rightarrow \begin{cases} t_1 = -1, \\ t_2 = 5. \end{cases}$$

Vaqt manfiy kattalik emas. Demak, moddiy nuqta harakat boshlangandan 5 sekund o'tgach to'xtaydi.

**Javob:** 5 s.

6-masala. Moddiy nuqta  $s(t) = -\frac{1}{6}t^3 + 3t^2 - 5$  qonuniyat bo'yicha harakatlanyapti. Uning tezlanishi nolga teng bo'lganda, tezligi qanchaga teng bo'ladi?

**Yechilishi.** (3) va (4) formulalardan foydalanib tezlik va tezlanishni  $t$  vaqtning funksiyalari sifatida ifodalaymiz:

$$v = s'(t) = -3 \cdot \frac{1}{6}t^2 + 2 \cdot 3t = \left(-\frac{1}{2}t^2 + 6t\right);$$

$$a = v'(t) = (-t + 6).$$

Masala shartidan foydalanib, harakat boshlangandan qancha vaqt birligi o'tgach moddiy nuqta tezlanishi nolga teng bo'lishini aniqlaymiz:

$$a = 0 \Leftrightarrow -t + 6 = 0 \Rightarrow t = 6 \text{ vaqt birligi.}$$

Topilgan vaqt birligining qiymatini tezlikning ifodasiga qo'yib, masala yechimini topamiz.

$$v = \left(-\frac{1}{2}t^2 + 6t\right)_{t=6} = -\frac{1}{2} \cdot 6^2 + 6 \cdot 6 = -18 + 36 = 18 \text{ tezlik birligi.}$$

**Javob:** 18 tezlik birligi.

## 7-§. Ba'zi elementar funksiyalarning hosilalari

Elementar funksiya deb darajali, ko'rsatkichli, logarifmik va trigonometrik funksiyalarga, shuningdek ularning turli kombinatsiyalariga aytiladi.

**7.1. Trigonometrik funksiyalarning hosilalari.** Sinusning va kosinusning hosilalarini topish formulalarini keltirib chiqarishda hosila ta'rifidan va birinchi ajoyib limitdan foydalanamiz.

$$\begin{aligned} 1. (\sin x)' &= \lim_{\Delta x \rightarrow 0} \frac{\sin(x+\Delta x) - \sin x}{\Delta x} = \lim_{\Delta x \rightarrow 0} \frac{2 \sin \frac{x+\Delta x-x}{2} \cos \frac{x+\Delta x+x}{2}}{\Delta x} = \\ &= \lim_{\Delta x \rightarrow 0} \frac{2 \sin \frac{\Delta x}{2} \cos \left(x + \frac{\Delta x}{2}\right)}{\Delta x} = \lim_{\Delta x \rightarrow 0} \frac{\sin \frac{\Delta x}{2}}{\frac{\Delta x}{2}} \lim_{\Delta x \rightarrow 0} \cos \left(x + \frac{\Delta x}{2}\right) = 1 \cdot \cos x = \cos x. \end{aligned}$$

Shunday qilib, sinusning hosilasi kosinusga teng:

$$(\sin x)' = \cos x. \quad (1)$$

$$\begin{aligned} 2. (\cos x)' &= \lim_{\Delta x \rightarrow 0} \frac{\cos(x+\Delta x) - \cos x}{\Delta x} = - \lim_{\Delta x \rightarrow 0} \frac{2 \sin \frac{x+\Delta x-x}{2} \sin \frac{x+\Delta x+x}{2}}{\Delta x} = \\ &= - \lim_{\Delta x \rightarrow 0} \frac{\sin \frac{\Delta x}{2}}{\frac{\Delta x}{2}} \sin \left(x + \frac{\Delta x}{2}\right) = - \lim_{\Delta x \rightarrow 0} \frac{\sin \frac{\Delta x}{2}}{\frac{\Delta x}{2}} \lim_{\Delta x \rightarrow 0} \sin \left(x + \frac{\Delta x}{2}\right) = -1 \cdot \sin x = \\ &= -\sin x. \end{aligned}$$

Demak, kosinusning hosilasi qarama-qarshi ishora bilan olingan sinusga teng:

$$(\cos x)' = -\sin x. \quad (2)$$

Tangensning va kotangensning hosilalari uchun formulalarni hosil qilishda bo'linmaning hosilasini topish qoidasidan (5-§, 5.2-band) foydalanamiz.

$$\begin{aligned} 3. (\operatorname{tg} x)' &= \left( \frac{\sin x}{\cos x} \right)' = \frac{(\sin x)' \cos x - \sin x (\cos x)'}{\cos^2 x} = \frac{\cos^2 x + \sin^2 x}{\cos^2 x} = \\ &= \frac{1}{\cos^2 x}. \text{ Demak,} \end{aligned}$$

$$(\operatorname{tg} x)' = \frac{1}{\cos^2 x}. \quad (3)$$

$$4. (\operatorname{ctg}x)' = \left(\frac{\cos x}{\sin x}\right)' = \frac{(\cos x)' \cdot \sin x - \cos x \cdot (\sin x)'}{\sin^2 x} = \frac{-\sin^2 x - \cos^2 x}{\sin^2 x} = -\frac{1}{\sin^2 x}.$$

Demak,

$$(\operatorname{ctg}x)' = -\frac{1}{\sin^2(x)}. \quad (4)$$

## 7.2. Teskari trigonometrik funksiyalarning hosilalari.

**Teorema.** Agar biror  $x$  nuqtada differensiallanuvchi va noldan farqli hosilaga ega bo'lgan  $y = f'(x)$  funksiyaning  $x = \varphi(y)$  teskari funksiyasi mavjud bo'lsa, u holda bu teskari funksiya ham shu nuqtada differensiallanuvchi bo'ladi va uning hosilasi

$$\varphi'(y) = \frac{1}{f'(x)} \quad (5)$$

ga teng bo'ladi.

1.  $y = \operatorname{arsin}x$  funksiyaning hosilasi. Bu funksiya sinusning teskari funksiyasi bo'lgani uchun  $x = \sin y$ . Demak,  $x' = (\sin y)' \Rightarrow x' = \cos y$

(5) formuladan  $y' = f'(x) = \frac{1}{\cos y} = \frac{1}{\sqrt{1-\sin^2 y}}$ .

Shunday qilib,

$$(\operatorname{arsin} x)' = \frac{1}{\sqrt{1-x^2}}. \quad (6)$$

2.  $y = \operatorname{arccos}x$  funksiyaning hosilasi:

$$(\operatorname{arccos} x)' = -\frac{1}{\sqrt{1-x^2}}. \quad (7)$$

3.  $y = \operatorname{arctg}x$  funksiyaning hosilasi:

$$(\operatorname{arctg}x)' = \frac{1}{1+x^2}. \quad (8)$$

4.  $y = \operatorname{arctg}x$  funksiyaning hosilasi:

$$(\operatorname{arctg}x)' = -\frac{1}{1+x^2}. \quad (9)$$

## 7.3. Logarifmik va ko'rsatkichli funksiyalarning hosilalari.

1.  $y = \log x$  funksiyaning hosilasi. Bu funksiyaning hosilasi uchun formulani keltirib chiqarishda hosila ta'rifidan va ikkinchi ajoyib limitdan foydalanamiz:

$$\lim_{\Delta x \rightarrow 0} \frac{\Delta y}{\Delta x} = \lim_{\Delta x \rightarrow 0} \frac{\log_a(x+\Delta x) - \log_a x}{\Delta x} = \lim_{\Delta x \rightarrow 0} \frac{\log_a \frac{x+\Delta x}{x}}{\Delta x} = \lim_{\Delta x \rightarrow 0} \frac{\log_a \left(1 + \frac{\Delta x}{x}\right)}{\Delta x} =$$

$$= \lim_{\Delta x \rightarrow 0} \log_a \left(1 + \frac{\Delta x}{x}\right)^{\frac{1}{\Delta x}} = \frac{1}{x} \lim_{\Delta x \rightarrow 0} \log_a \left(1 + \frac{\Delta x}{x}\right)^{\frac{x}{\Delta x}}$$

$\frac{\Delta x}{x} = \alpha$  belgilash kiritamiz.  $\Delta x \rightarrow 0$  da  $\alpha \rightarrow 0$ . U holda

$$\lim_{\alpha \rightarrow 0} (1 + \alpha)^\alpha = e \text{ ekanligidan}$$

$$\lim_{\Delta x \rightarrow 0} \frac{\Delta y}{\Delta x} = \frac{1}{x} \log_a e = \frac{1}{x \ln a}.$$

Shunday qilib,

$$(\log_a x)' = \frac{1}{x} \log_a e = \frac{1}{x \ln a}. \quad (10)$$

Agar  $a = e$  bo'lsa,

$$(\ln x)' = \frac{1}{x} \quad (11)$$

ga ega bo'lamiz.

2.  $y = a^x$  **funksiyaning hosilasi**. Ko'rsatkichli funksiya hosilasini topishda **logarifmlash usulidan** foydalanamiz.  $y = a^x$  tenglikning har ikki qismini  $e$  asos bo'yicha logarifmlaymiz.

$$\ln y = x \ln a.$$

Hosil bo'lgan tenglikning har ikkala qismini differensiallaymiz:

$$\frac{y'}{y} = \ln a.$$

Bundan  $y' = y \ln a$  yoki  $y' = a^x \ln a$ .

Shunday qilib,

$$(a^x)' = a^x \ln a. \quad (12)$$

Agar  $a = e$  bo'lsa,

$$(e^x)' = e^x. \quad (13)$$

#### 7.4. Asosiy elementar funksiyalarni differensiallash formulalari

$u = \varphi(x)$  bo'lsa:

1.  $(u^p)' = pu^{p-1} \cdot u'$ .
2.  $(\sin u)' = u' \cdot \cos u$ .
3.  $(\cos u)' = -u' \cdot \sin u$ .

$u = x$  bo'lsa:

- $(x^p)' = px^{p-1}$ .
- $(\sin x)' = \cos x$ .
- $(\cos x)' = -\sin x$ .

$$4. (\operatorname{tgu})' = \frac{u'}{\cos^2 u}$$

$$5. (\operatorname{ctgu})' = -\frac{u'}{\sin^2 u}$$

$$6. (\log_a u)' = \frac{u'}{u} \log_a e = \frac{u'}{u \ln a}$$

$$(\ln u)' = \frac{u'}{u}$$

$$7. (a^u)' = u' \cdot a^u \ln a$$

$$(e^u)' = u' \cdot e^u$$

$$8. (\arcsin u)' = \frac{u'}{\sqrt{1-u^2}}$$

$$9. (\arccos u)' = -\frac{u'}{\sqrt{1-u^2}}$$

$$10. (\operatorname{arctgu})' = \frac{u'}{1+u^2}$$

$$11. (\operatorname{arccetgu})' = -\frac{u'}{1+u^2}$$

$$(\operatorname{tg} x)' = \frac{1}{\cos^2 x}$$

$$(\operatorname{ctg} x)' = -\frac{1}{\sin^2 x}$$

$$\log_a x = \frac{1}{x} \log_a e = \frac{1}{x \ln a}$$

$$(\ln x)' = \frac{1}{x}$$

$$(a^x)' = a^x \ln a$$

$$(e^x)' = e^x$$

$$(\arcsin x)' = \frac{1}{\sqrt{1-x^2}}$$

$$(\arccos x)' = -\frac{1}{\sqrt{1-x^2}}$$

$$(\operatorname{arctg} x)' = \frac{1}{1+x^2}$$

$$(\operatorname{arccetg} x)' = -\frac{1}{1+x^2}$$

Differensiallash qoidalari va formulalaridan foydalanib quyidagi funksiyalar hosilalarini toping.

$$1) y = \sqrt{2x} + \frac{1}{\sqrt{x}} + 0,1x^{10};$$

$$2) y = x \cdot \sin 2x;$$

$$3) y = \cos(x^2 - 3);$$

$$4) y = \sin x^3 + \cos 3x;$$

$$5) y = \frac{1 - \cos x}{1 + \cos x};$$

$$6) y = -\operatorname{ctg} \frac{x}{2} - \frac{1}{3} \operatorname{ctg}^3 \frac{x}{2};$$

$$7) y = \operatorname{tg}^2 \sqrt{2x};$$

$$8) y = \ln \cos^2 x;$$

$$9) y = \log_2(x^2 + 3x);$$

$$10) y = \frac{1 - e^x}{e^x};$$

$$11) y = x \cdot 2^{3x};$$

$$12) y = e^{\sin^2 x};$$



13)  $y = \arccos \sqrt{x}$ ;

14)  $y = \operatorname{arctg}(\ln x)$ .

Yechilishi.

$$1) y' = \left( \sqrt{2x} + \frac{1}{\sqrt{x}} + 0,1 \cdot x^{10} \right)' = \left( (2x)^{\frac{1}{2}} \right)' + \left( x^{-\frac{1}{2}} \right)' + \\ + (0,1x^{10})' = \frac{1}{2} (2x)^{\frac{1}{2}-1} \cdot (2x)' - \frac{1}{2} x^{-\frac{1}{2}-1} + 10 \cdot 0,1 \cdot x^{10-1} = \frac{2}{2(2x)^{\frac{1}{2}}} - \frac{1}{2x^{\frac{3}{2}}} + \\ + x^9 = \frac{1}{\sqrt{2x}} - \frac{1}{2x\sqrt{x}} + x^9.$$

Javob:  $\frac{1}{\sqrt{2x}} - \frac{1}{2x\sqrt{x}} + x^9$ .

2)  $y' = (x \sin 2x)' = x' \sin 2x + x \cdot (\sin 2x)' = \sin 2x + 2x \cos 2x$ .

Javob:  $\sin 2x + 2x \cos 2x$ .

3)  $y' = (\cos(x^2 - 3))' = -(x^2 - 3)' \sin(x^2 - 3) = -2x \sin(x^2 - 3)$ .

Javob:  $-2x \sin(x^2 - 3)$ .

4)  $y' = (\sin x^3 + \cos 3x)' = 3x^2 \cos x^3 - 3 \sin 3x$ .

Javob:  $3x^2 \cos x^3 - 3 \sin 3x$ .

5)  $y = \frac{1 - \cos x}{1 + \cos x} = \frac{2 \sin^2 \frac{x}{2}}{2 \cos^2 \frac{x}{2}} = \operatorname{tg}^2 \frac{x}{2}$ .

$$y' = \left( \operatorname{tg}^2 \frac{x}{2} \right)' = 2 \operatorname{tg} \frac{x}{2} \cdot \frac{\left( \frac{x}{2} \right)'}{\cos^2 \frac{x}{2}} = \frac{\sin \frac{x}{2}}{\cos^3 \frac{x}{2}}$$

Javob:  $\frac{\sin \frac{x}{2}}{\cos^3 \frac{x}{2}}$ .

$$6) y' = \left( -\operatorname{ctg} \frac{x}{2} - \frac{1}{3} \operatorname{ctg}^3 \frac{x}{2} \right)' = \frac{1}{2} \cdot \frac{1}{\sin^2 \frac{x}{2}} + \frac{1}{3} \cdot 3 \cdot \frac{1}{2} \operatorname{ctg}^2 \frac{x}{2} \cdot \frac{1}{\sin^2 \frac{x}{2}} = \\ = \frac{1}{2 \sin^2 \frac{x}{2}} + \frac{\operatorname{ctg}^2 \frac{x}{2}}{2 \sin^2 \frac{x}{2}} = \frac{1 + \operatorname{ctg}^2 \frac{x}{2}}{2 \sin^2 \frac{x}{2}} = \frac{1}{2 \sin^4 \frac{x}{2}}$$

Javob:  $\frac{1}{2\sin^4 x}$ .

$$7) y' = (\operatorname{tg}^2 \sqrt{2x})' = 2\operatorname{tg} \sqrt{2x} \cdot (\operatorname{tg} \sqrt{2x})' = 2\operatorname{tg} \sqrt{2x} \cdot \frac{(\sqrt{2x})'}{\cos^2 \sqrt{2x}} =$$

$$= \frac{\sqrt{2x} \cdot \sin \sqrt{2x}}{x \cos^3 \sqrt{2x}}.$$

Javob:  $\frac{\sqrt{2x} \cdot \sin \sqrt{2x}}{x \cos^3 \sqrt{2x}}$ .

$$8) y' = (\ln \cos^2 x)' = \frac{(\cos^2 x)'}{\cos^2 x} = -\frac{2\cos x \sin x}{\cos^2 x} = -2\operatorname{tg} x.$$

Javob:  $-2 \operatorname{tg} x$ .

$$9) y' = (\log_2(x^2 + 3x))' = \frac{(x^2 + 3x)'}{(x^2 + 3x)\ln 2} = \frac{2x + 3}{(x^2 + 3x)\ln 2}.$$

Javob:  $\frac{2x + 3}{(x^2 + 3x)\ln 2}$ .

$$10) y' = \left(\frac{1 - e^x}{e^x}\right)' = (e^{-x} - 1)' = -e^{-x}.$$

Javob:  $-e^{-x}$ .

$$11) y' = (x \cdot 2^{3x})' = 1 \cdot 2^{3x} + x \cdot 2^{3x} \cdot 3 \ln 2 = 2^{3x}(1 + 3x \ln 2).$$

Javob:  $2^{3x}(1 + 3x \ln 2)$ .

$$12) y' = \left(e^{\sin^2 x}\right)' = e^{\sin^2 x} \cdot 2 \sin x \cdot \cos x = \sin 2x \cdot e^{\sin^2 x}.$$

Javob:  $\sin 2x \cdot e^{\sin^2 x}$ .

$$13) y' = (\arccos \sqrt{x})' = -\frac{(\sqrt{x})'}{\sqrt{1-x}} = -\frac{\frac{1}{2\sqrt{x}}}{\sqrt{1-x}} = -\frac{1}{2\sqrt{x(1-x)}}.$$

Javob:  $-\frac{1}{2\sqrt{x(1-x)}}$ .

$$14) y' = (\operatorname{arctg}(\ln x))' = \frac{(\ln x)'}{1 + \ln^2 x} = \frac{1}{x(1 + \ln^2 x)}.$$

Javob:  $\frac{1}{x(1 + \ln^2 x)}$ .

## 8-§. Hosilaning taqribiy hisoblashlarga tatbiqi

8.1. **Funksiya orttirmasining bosh qismi.** Biror  $y = f(x)$  funksiya  $[a; b]$  kesmada differensiallanuvchi bo'lsin, ya'ni

$$f'(x) = \lim_{\Delta x \rightarrow 0} \frac{\Delta y}{\Delta x}. \quad (1)$$

Bu tenglikni  $f'(x) \neq 0$  deb faraz qilib,

$$\frac{\Delta y}{\Delta x} = f'(x) + \alpha \quad (2)$$

ko'rinishda yozish mumkin, bunda  $\Delta x \rightarrow 0$  da  $\alpha \rightarrow 0$ . Demak, yetarlicha kichik barcha  $\Delta x$  lar uchun ushbu

$$\frac{\Delta y}{\Delta x} \approx f'(x) \quad (3)$$

taqribiy tenglik o'rinli. (2) tenglikda hamma hadlarni  $\Delta x$  ga ko'paytirib,

$$\Delta y = f'(x) \Delta x + \alpha \cdot \Delta x$$

munosabatga ega bo'lamiz.  $\beta = \alpha \cdot \Delta x$  deb belgilasak,

$$\Delta y = f'(x) \Delta x + \beta. \quad (4)$$

(4) tenglikdagi birinchi qo'shiluvchi  $f'(x) \cdot \Delta x$  **funksiya orttirmasining bosh qismi** yoki **funksiyaning differensial** deyiladi va  $dy$  yoki  $df(x)$  kabi belgilanadi. Shunday qilib,

$$dy = f'(x) \cdot \Delta x \quad (5)$$

$y = x$  funksiyaning differensialini topaylik.  $y' = 1$  bo'lgani uchun

$$dy = dx = 1 \cdot \Delta x$$

yoki

$$dx = \Delta x,$$

ya'ni erkli o'zgaruvchi orttirmasi uning differensialiga teng. Demak, (5) formulani

$$dy = f'(x)dx \quad (6)$$

shaklda yozish mumkin. Bundan

$$f'(x) = \frac{dy}{dx}.$$

ya'ni hosilani funksiya differensialining erkli o'zgaruvchi differensialiga nisbati deb qarash mumkin.

1-misol.  $y = \sin x$  funksiya differensialini toping.

Yechilishi.  $y' = \cos x$  bo'lgani uchun (6) formulaga ko'ra

$$dy = \cos x dx.$$

Javob:  $\cos x dx$ .

2-misol.  $y = \ln x$  funksiya differensialini toping.

Yechilishi.  $y' = \frac{1}{x}$  bo'lgani uchun  $dy = \frac{dx}{x}$ .

Javob:  $dy = \frac{dx}{x}$ .

**8.2. Taqribiy hisoblashlarda differensialdan foydalanish.** (3) taqribiy tenglikni quyidagicha yozish mumkin:

$$\Delta y \approx dy$$

yoki

$$f(x + \Delta x) - f(x) \approx f'(x) \Delta x.$$

Bundan taqribiy hisoblashlarda keng qo'llaniladigan

$$f(x + \Delta x) \approx f(x) + f'(x) \Delta x \quad (7)$$

formulaga ega bo'lamiz. Agar  $f(x)$ ,  $f'(x)$  va  $x$  ma'lum bo'lsa, (7) taqribiy tenglikdan funksiyaning  $x$  nuqtadagi qiymatini bilgan holda uning  $x + \Delta x$  nuqtadagi qiymatini taqribiy hisoblashda foydalaniladi. Bu qiymat  $\Delta x$  qancha kichik bo'lsa, shuncha aniq bo'ladi.

(7) formulani tatbiqiga doir bir nechta masalalar qaraymiz.

1-masala.  $y = \sqrt[n]{x}$  funksiya uchun taqribiy hisoblash formulasini keltirib chiqaring.

Yechilishi.  $y' = \frac{1}{n \cdot x^{\frac{n-1}{n}}} = \frac{1}{n \sqrt[n]{x^{n-1}}}$  bo'lgani uchun

$$dy = \frac{dx}{n \sqrt[n]{x^{n-1}}} = \frac{\sqrt[n]{x}}{nx} dx$$

ga egamiz.  $\Delta y \approx dy$ ,  $\Delta x \approx dx$  ekanligidan

$$\sqrt[n]{x + \Delta x} \approx \sqrt[n]{x} + \frac{\sqrt[n]{x}}{nx} \Delta x \quad (8)$$

ga ega bo'lamiz. Xususiyl holda, agar  $x = 1$  bo'lsa, (8) formula ushbu ko'rinishda yoziladi:

$$\sqrt[n]{1 + \Delta x} \approx 1 + \frac{\Delta x}{n}. \quad (9)$$

Hosil qilingan (8) formulani  $\sqrt[3]{24}$  ning taqribiy qiymatini hisoblashga tatbiq qilamiz. Bunda  $n = 3$ ,  $x = 27$ ,  $\Delta x = -3$  desak.

$$\sqrt[3]{24} = \sqrt[3]{27 - 3} \approx \sqrt[3]{27} + \frac{\sqrt[3]{27}}{3 \cdot 27} (-3) = 3 - \frac{1}{9} = 2, (8).$$

(9) formulani  $\sqrt{1,1}$  ning taqribiy qiymatini topishga tatbiqini ko'raylik. Bunda  $n = 2$ ,  $\Delta x = 0,1$  deb olsak,

$$\sqrt{1,1} \approx 1 + \frac{0,1}{2} = 1,05.$$

2-masala.  $\sin 31^\circ$  ning taqribiy qiymatini 0,0001 aniqlikda hisoblang.

Yechilishi.  $x = \frac{\pi}{6}$  ning  $30^\circ$  li burchakka,  $\Delta x = \frac{\pi}{180}$  ning  $1^\circ$  li burchakka mos kelishini e'tiborga olib, (7) formulaga ko'ra ushbuga ega bo'lamiz:

$$\begin{aligned} \sin 31^\circ &= \sin \left( \frac{\pi}{6} + \frac{\pi}{180} \right) \approx \sin \frac{\pi}{6} + \left( \cos \frac{\pi}{6} \right) \cdot \frac{\pi}{180} \approx \\ &\approx 0,5 + 0,8660 \cdot 0,0174 = 0,5151. \end{aligned}$$

Javob: 0,5151.

### 9-§. Hosilani funksiyalarining o'sish va kamayish oraliqlarini topishga tatbiqi

Biror  $(a, b)$  oraliqda  $y = f(x)$  funksiya hosilasining qiymatlari musbat, ya'ni  $f'(x) > 0$  bo'lsa, u holda shu oraliqning har bir nuqtasida funksiya grafigiga o'tkazilgan urinmaning burchak koeffitsiyenti  $k = \operatorname{tg} \alpha = f'(x)$  (6-§ ga qarang) musbat bo'ladi. Bu funksiya grafigiga o'tkazilgan urinmalarning  $Ox$  o'qining musbat yo'nalishi bilan hosil qilgan burchaklari o'tkir bo'lgandagina mumkin bo'ladi (165-a rasm). Demak,  $y = f(x)$  funksiyaning grafigi  $x$  argumentning qiymati ortishi bilan yuqoriga ko'tarila boradi. Bu esa funksiyaning monoton o'sishini bildiradi.

$(a, b)$  oraliqda  $f'(x) < 0$  bo'lsa, funksiya grafigiga o'tkazilgan urinmalarning burchak koeffitsiyentlari manfiy bo'ladi va urinma-

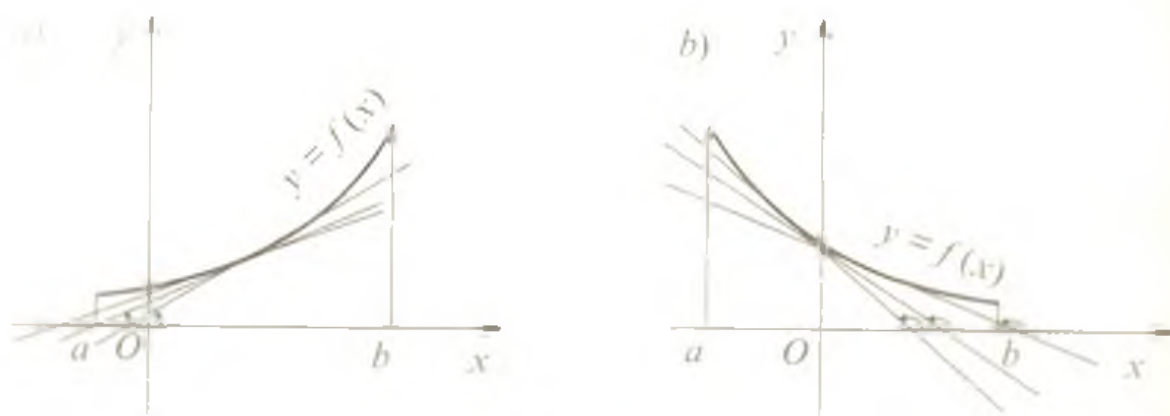

165-rasm

larning  $Ox$  o'qining musbat yo'nalishi bilan hosil qilgan burchaklari o'tmas burchak bo'lib (165-b rasm),  $y = f(x)$  funksiyaning grafigi  $x$  argumentning qiymati ortgan sari pastga tusha boradi. Bu esa funksiyaning qaralayotgan oraliqda monoton kamayishini bildiradi.

**Teorema (funksiya o'sishining (kamayishining) yetarlilik sharti).**

1) Agar  $y = f(x)$  funksiya  $(a; b)$  oraliqning har bir nuqtasida musbat hosilaga ega bo'lsa ( $f'(x) > 0$ ), u holda shu oraliqda monoton o'sadi;

2) agar  $y = f(x)$  funksiya  $(a; b)$  oraliqning har bir nuqtasida manfiy hosilaga ega bo'lsa ( $f'(x) < 0$ ), u holda shu oraliqda monoton kamayadi.

Agar  $y = f(x)$  funksiya  $(a; b)$  oraliqda monoton bo'lib,  $a$  va  $b$  nuqtalarda uzluksiz bo'lsa, u holda bu funksiya  $[a; b]$  kesmada ham monoton ekanligini eslatib o'tamiz.

1-misol.  $y = \frac{1}{3}x^3 - 64x$  funksiyaning o'sish oraliqlarini toping.

Yechilishi. Dastlab funksiyaning hosilasini topamiz:  $y' = x^2 - 64$ .

So'ngra  $f'(x) \geq 0$  tengsizlikni, ya'ni  $x^2 - 64 \geq 0$  tengsizlikni yechib, funksiyaning o'sish oraliqini topamiz:

$$x^2 - 64 \geq 0 \Rightarrow (x-8)(x+8) \geq 0 \Rightarrow x \in (-\infty; -8] \cup [8; +\infty).$$

Javob:  $(-\infty; -8] \cup [8; +\infty)$ .

2-misol.  $y = x \cdot e^{-3x}$  funksiyaning kamayish oraliqini toping.

Yechilishi.  $y' = e^{-3x} - 3xe^{-3x} \leq 0 \Leftrightarrow e^{-3x}(1-3x) \leq 0 \Leftrightarrow$

$$\Leftrightarrow 3x-1 \geq 0 \Rightarrow \left[ x \geq \frac{1}{3} \right].$$

Javob:  $\left[ \frac{1}{3}; +\infty \right)$ .

3-misol.  $y = 3x + 2 \cos 3x$  funksiyaning o'sish oraliqlarini toping.

Yechilishi.  $y' = 3 - 6 \sin 3x \geq 0 \Leftrightarrow \sin 3x \leq \frac{1}{2} \Rightarrow 2k\pi - \frac{7\pi}{6} \leq$

$$\leq 3x \leq \frac{\pi}{6} + 2k\pi \Leftrightarrow \frac{2k\pi}{3} - \frac{7\pi}{18} \leq x \leq \frac{\pi}{18} + \frac{2k\pi}{3}, k \in Z.$$

Javob:  $\left[ \frac{2k\pi}{3} - \frac{7\pi}{18}; \frac{\pi}{18} + \frac{2k\pi}{3} \right], k \in Z.$

## 10-§. Funksiyaning ekstremumlari

**10.1. Funksiyaning maksimumi va minimumi.** Funksiyalarni tekshirishda erkli o'zgaruvchi  $x$  ning o'sish va kamayish oralig'larini ajratuvchi qiymatlari muhim ahamiyat kasb etadi. Bu qiymatlardan o'tilayotganda (chapdan o'ngga) o'suvchi funksiya kamayuvchi bo'lib qoladi yoki, aksincha, kamayuvchi funksiya o'sa boshlaydi.

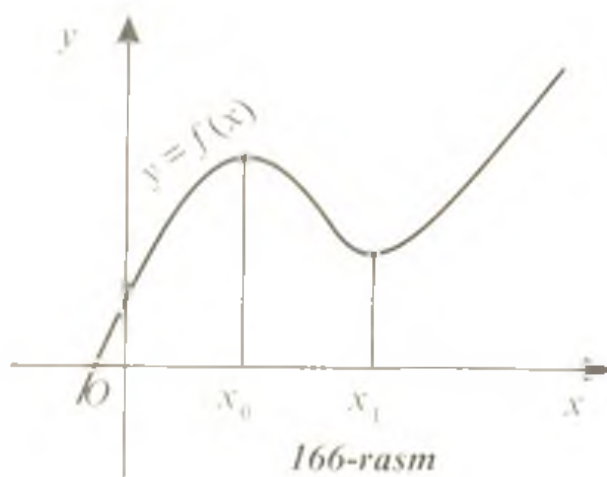

166-rasmda  $x_0$  nuqta o'sish oralig'ini kamayish oralig'idan.  $x_1$  nuqta esa kamayish oralig'ini o'sish oralig'idan ajratadi.  $x_0$  nuqtaning shunday atrofi mavjudki, shu atrofdagi barcha nuqtalarda funksiyaning qiymati  $x_0$  nuqtadagi qiymatidan kichik.  $x_1$  nuqtaning ham shunday atrofi mavjudki, bu atrofdagi barcha nuqtalarda funksiyaning qiymati  $x_1$

nuqtadagi qiymatidan katta.

**Ta'rif.** *Funksiyaning aniqlanish sohasiga tegishli  $x_0$  nuqtaning shunday  $\delta$ -atrofi  $(x_0 - \delta; x_0 + \delta)$  mavjud bo'lsaki, shu atrofga tegishli barcha  $x \neq x_0$  nuqtalar uchun  $f(x) < f(x_0)$  tengsizlik bajarilsa,  $x_0$  nuqta funksiyaning maksimum nuqtasi deb ataladi (167-a rasm).*

**Ta'rif.** *Funksiyaning aniqlanish sohasiga tegishli  $x_0$  nuqtaning shunday  $\delta$ -atrofi  $(x_0 - \delta; x_0 + \delta)$  mavjud bo'lsaki, shu atrofga tegishli barcha  $x \neq x_0$  nuqtalar uchun  $f(x) > f(x_0)$  tengsizlik bajarilsa,  $x_0$  nuqta funksiyaning minimum nuqtasi deb ataladi (167-b rasm).*

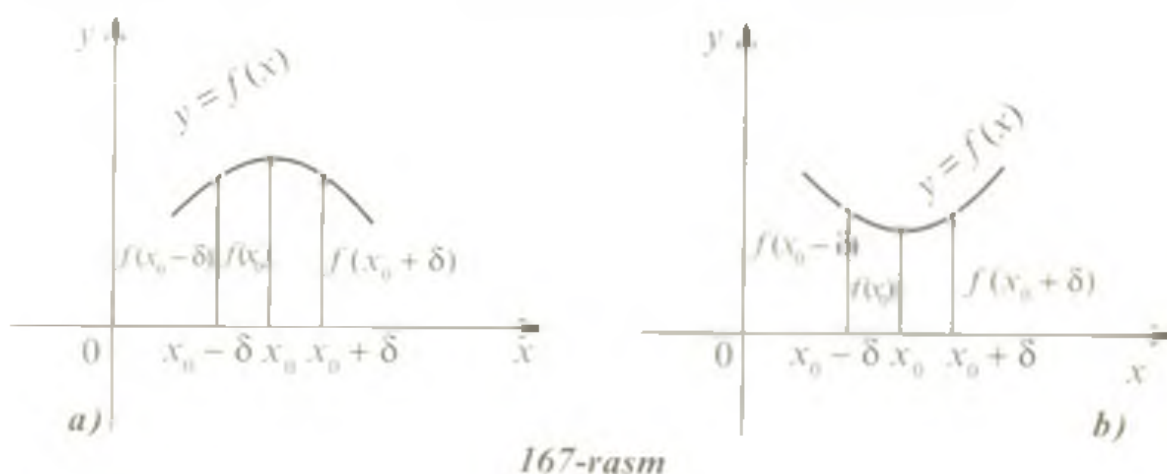

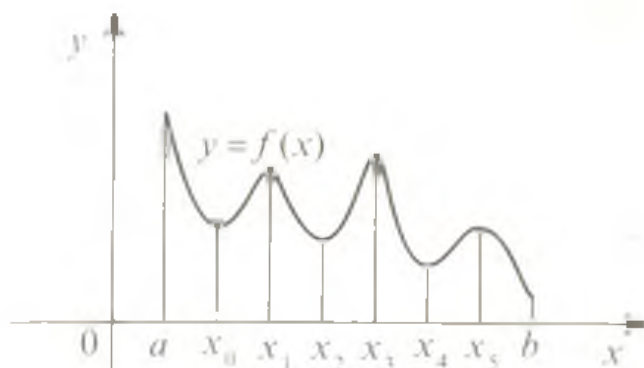

168-rasm

talarda minimumlarga ( $y_{\min}$ ),  $x_1, x_3, x_5$  nuqtalarda esa maksimumlarga ( $y_{\max}$ ) ega.  $[a; b]$  kesmaning  $a$  va  $b$  nuqtalari funksiyaning aniqlanish sohasiga tegishli atrofga ega bo'lmaganligi sababli  $f(x)$  funksiyaning ekstremum nuqtalari bo'lib hisoblanmasligini eslatib o'tamiz.

**10.2. Ekstremum mavjudligining zaruriy sharti.** Nuqta ekstremum nuqtasi bo'lishining zaruriy sharti Ferma teoremasida keltiriladi.

**Teorema.** Agar  $x_0$  nuqta  $f(x)$  funksiyaning ekstremum nuqtasi bo'lsa va bu nuqtada hosila mavjud bo'lsa, bu hosila nolga teng bo'ladi:  $f'(x_0) = 0$ .

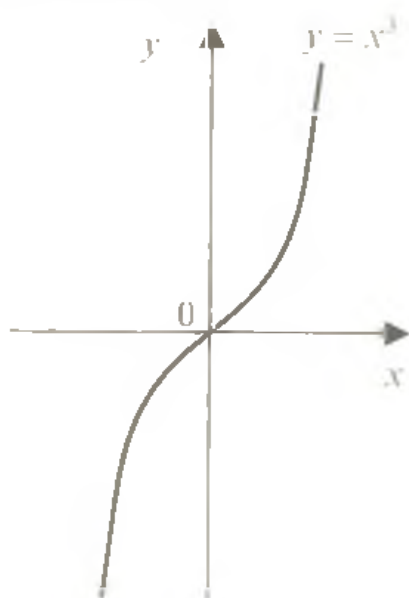

170-rasm

Ferma teoremasining geometrik ma'nosi ekstremum nuqtasida urinma abssissalar o'qiga parallel ekanligini va shuning uchun uning  $k = f'(x_0)$  burchak koeffitsiyenti nolga teng bo'lishini anglatadi (169-rasm).

Ferma teoremasi ekstremumning zaruriy shartidir xolos: hosilaning  $x_0$  nuqtada 0 ga teng bo'lishidan bu nuqtada funksiya albatta ekstremumga ega ekanligi kelib chiqmaydi.

Masalan,  $y = x^3$  funksiyaning hosilasi  $y' = 3x^2$   $x = 0$  nuqtada nolga teng, lekin funksiya bu nuqtada ekstremumga ega emas, chunki u butun sonlar o'qida o'sadi (170-rasm).

Funksiyaning maksimum va minimum nuqtalari uning *ekstremum nuqtalari* deyilib, bu nuqtalardagi qiymatlari mos ravishda funksiyaning *maksimumi* va *minimumi* (*ekstremumlari*) deyiladi. Grafigi 168-rasmda tasvirlangan  $[a; b]$  kesmada aniqlangan funksiya  $x_0, x_2, x_4$  nuq-

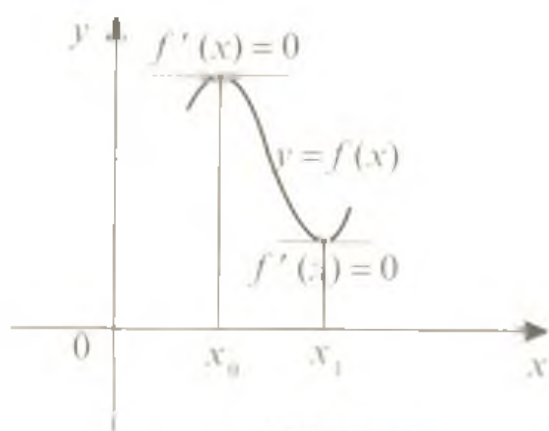

169-rasm



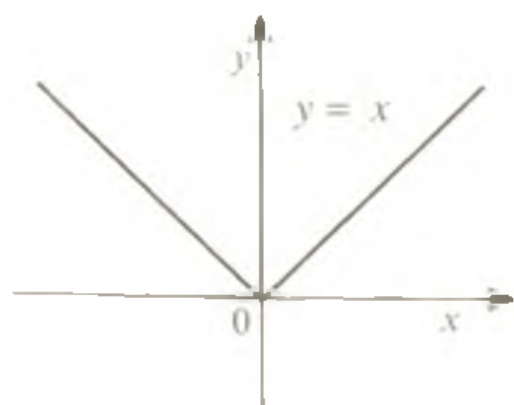

171-rasm

Demak, agar  $f'(x) = 0$  bo'lsa, u holda bu nuqta albatta funktsiyaning ekstremum nuqtasi bo'ladi, deb tasdiqlash yetarli emas va qo'shimcha tekshirishni talab qiladi.

Funktsiyaning hosilasi nolga teng bo'ladigan nuqtalar *statsionar nuqtalar* deb ataladi.

Funktsiya hosilasi mavjud bo'lmaydigan nuqtalarda ham ekstremumga ega bo'lishi yoki ega bo'lmasligi mumkin.

1-misol.  $y = |x|$  funktsiya  $x = 0$  nuqtada hosilaga ega emas, ammo bu nuqtada minimumga ega (171-rasm).

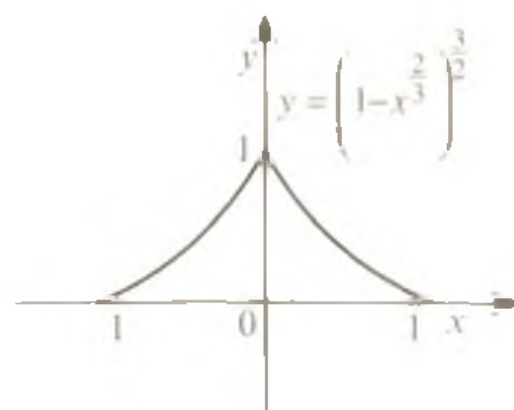

172-rasm

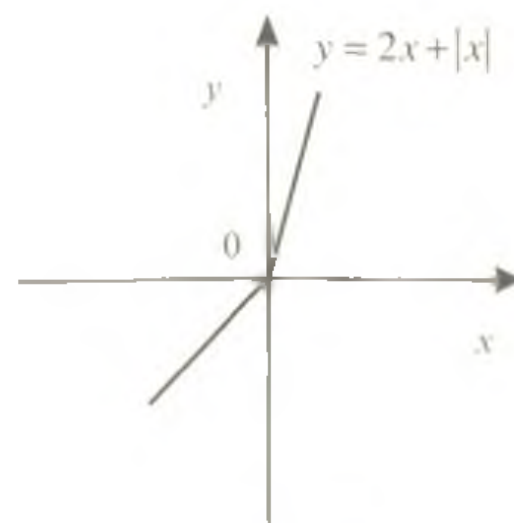

173-rasm

2-misol.  $y = \left(1 - x^3\right)^{\frac{2}{3}}$  funktsiya  $x = 0$  nuqtada aniqlangan va maksimumga ega, lekin uning

$$y' = -\frac{\left(1 - x^3\right)^{\frac{1}{3}}}{x^3}$$

hosilasi bu nuqtada mavjud emas (cheksizlikka aylanadi) (172-rasm).

3-misol.  $y = 2x + |x|$  funktsiya  $x = 0$  nuqtada ekstremumga ega emas, bu nuqtada funktsiya hosilaga ham ega emas (173-rasm).

Ta'rif. *Funktsiya aniqlanish sohasining hosila mavjud bo'lmaydigan yoki nolga teng bo'ladigan ichki nuqtalari funktsiyaning kritik nuqtalari deyiladi.*

**10.3. Ekstremumning yetarlilik shartlari.** Statsionar nuqta ekstremum nuqtasi bo'lishligining yetarlilik shartlarini keltiramiz.

1. Ekstremumning birinchi yetarlilik shartlari.

**Teorema.** Agar  $f(x)$  funksiya  $x_0$  nuqtada uzluksiz bo'lib,  $(a; x_0)$  oraliqda  $f'(x) > 0$  va  $(x_0; b)$  oraliqda  $f'(x_0) < 0$  bo'lsa, u holda  $x_0$  nuqta  $f(x)$  funksiyaning maksimum nuqtasi bo'ladi.

**Teorema.** Agar  $f(x)$  funksiya  $x_0$  nuqtada uzluksiz bo'lib,  $(a; x_0)$  oraliqda  $f'(x) < 0$  va  $(x_0; b)$  oraliqda  $f'(x_0) > 0$  bo'lsa, u holda  $x_0$  nuqta  $f(x)$  funksiyaning minimum nuqtasi bo'ladi.

Bu teoremlarning ushbu soddalashtirilgan mazmunidan foydalanish qulay: agar  $f(x)$  funksiyaning hosilasi statsionar nuqtadan chapda musbat, o'ngda esa manfiy bo'lsa, ya'ni bu nuqtadan o'tishda hosila ishorasini + dan - ga almashtirsa, u holda bu statsionar nuqta funksiyaning maksimum nuqtasi bo'ladi. Agar hosila statsionar nuqtadan chapda manfiy, o'ngda esa musbat bo'lsa, ya'ni bu nuqtadan o'tishda hosila ishorasini - dan + ga almashtirsa, u holda bu statsionar nuqta funksiyaning minimum nuqtasi bo'ladi.

4-misol.  $y = 6x^4 - 8x^3 - 3x^2 + 6x$  funksiyaning ekstremumlarini toping.

Yechilishi. Funksiya hosilasini topamiz:

$$y' = 24x^3 - 24x^2 - 6x + 6 = 6(4x^3 - 4x^2 - x + 1).$$

statsionar nuqtalarni topamiz:

$$6(4x^3 - 4x^2 - x + 1) = 0 \Leftrightarrow 4x^2(x-1) - (x-1) = 0 \Leftrightarrow (x-1)(4x^2 - 1) =$$

$$= 0 \Leftrightarrow (x-1)(2x-1)(2x+1) = 0 \Rightarrow \begin{cases} x_1 = -\frac{1}{2}, \\ x_2 = \frac{1}{2}, \\ x_3 = 1. \end{cases}$$

Bu nuqtalar sonlar o'qini  $(-\infty; -\frac{1}{2})$ ,  $(-\frac{1}{2}; \frac{1}{2})$ ,  $(\frac{1}{2}; 1)$  va  $(1; +\infty)$  oraliqlarga ajratadi. Bu oraliqlarning har birida hosila ishorasini aniqlaymiz (174-rasm):  $y'(-1) < 0$ ;  $y'(0) > 0$ ;  $y'(\frac{3}{4}) < 0$ ;  $y'(2) > 0$ ;

$x = -\frac{1}{2}$  va  $x = 1$  nuqtalarda hosila ishorasini - dan + ga almash-tiryapti, demak, bu nuqtalar funksiyaning minimum nuqtalari.  $x = \frac{1}{2}$



174-rasm

nuqtadan o'tayotganda hosila ishorasi + dan - ga almashadi, shu sababli bu nuqta funksiyaning maksimum nuqtasi bo'ladi.

Funksiyaning bu nuqtalardagi qiymatlarini hisoblab, uning ekstremumlarini topamiz:

$$y_{\min} \left(-\frac{1}{2}\right) = -2\frac{3}{8}; \quad y_{\min}(1) = 1; \quad y_{\max} \left(\frac{1}{2}\right) = 1\frac{5}{8}.$$

2. Ekstremumning ikkinchi yetarlilik sharti.

**Teorema.** Agar  $f'(x_0) = 0$  bo'lib, ikkinchi hosila mavjud va u noldan farqli ( $f''(x_0) \neq 0$ ) bo'lsa, u holda  $x_0$  nuqta funksiyaning ekstremum nuqtasidir; agar  $f''(x_0) < 0$  bo'lsa,  $x_0$  nuqta funksiyaning maksimum nuqtasi, agar  $f''(x_0) > 0$  bo'lsa, minimum nuqtasi bo'ladi.

5-misol.  $y = \cos^2 x - \sin x$  funksiyaning ekstremumlarini toping.

**Yechilishi.** Berilgan funksiyaning eng kichik musbat davri  $2\pi$  ga teng. Shu sababli uning ekstremumlarini  $[-\pi; \pi]$  kesmada topish yetarli. Funksiyaning hosilasini topamiz:

$$y' = -2\cos x \sin x - \cos x.$$

Funksiyaning  $[-\pi; \pi]$  kesmaga tegishli statsionar nuqtalarini topamiz:

$$-2\cos x \sin x - \cos x = 0 \Leftrightarrow \cos x (2\sin x + 1) = 0 \Leftrightarrow \begin{cases} \cos x = 0, \\ \sin x = -\frac{1}{2}. \end{cases} \Rightarrow$$

$$x_1 = -\frac{5\pi}{6}; \quad x_2 = -\frac{\pi}{2}; \quad x_3 = -\frac{\pi}{6}; \quad x_4 = \frac{\pi}{2}.$$

Funksiya ekstremumlarini topishda ikkinchi yetarlilik shartidan foydalanamiz:

$$y'' = (-2\cos x \sin x - \cos x)' = (-\sin 2x - \cos x)' = -2\cos 2x + \sin x.$$

$$y''\left(-\frac{5\pi}{6}\right) = -2 \cdot \frac{1}{2} - \frac{1}{2} < 0; \quad y''\left(-\frac{\pi}{2}\right) = -2 \cdot (-1) - 1 > 0;$$

$$y''\left(-\frac{\pi}{6}\right) = -2 \cdot \frac{1}{2} - \frac{1}{2} < 0; \quad y''\left(\frac{\pi}{2}\right) = -2 \cdot (-1) + 1 > 0.$$

Shunday qilib,

$$y_{\max}\left(-\frac{5\pi}{6}\right) = 1\frac{1}{4}; \quad y_{\min}\left(-\frac{\pi}{2}\right) = 1;$$

$$y_{\max}\left(-\frac{\pi}{6}\right) = 1\frac{1}{4}; \quad y_{\min}\left(\frac{\pi}{2}\right) = -1.$$

$$\text{Javob: } y_{\max}\left(-\frac{5\pi}{6}\right) = y_{\max}\left(-\frac{\pi}{6}\right) = 1\frac{1}{4};$$

$$y_{\max}\left(-\frac{\pi}{2}\right) = 1; \quad y_{\min}\left(\frac{\pi}{2}\right) = -1.$$

## 11-§. Funksiyani hosila yordamida tekshirish va uning grafigini yasash

Ko'pchilik hollarda funksiya grafigi «nuqtalar bo'yicha» – erkli o'zgaruvchining qiymatlariga mos keluvchi funksiya qiymatlarini hisoblash yo'li bilan yasaladi. Grafik yasashning bu usulida funksiyaning ayrim muhim xususiyatlari e'tibordan chetda qolishi, masalan, ekstremum nuqtalari noto'g'ri tasvirlanishi yoki umuman o'tkazilib yuborilishi mumkin. Shuning uchun grafik yasashni funksiyaning tekshirishdan boshlash maqsadga muvofiqdir. Buni quyidagi ketma-ketlikda bajarish tavsiya etiladi:

- 1) Funksiyaning aniqlanish sohasini topish;
- 2) Funksiya nollarini (agar ular mavjud bo'lsa) topish;
- 3) Funksiyaning juft yoki toqligini aniqlash;
- 4) Funksiyaning hosilasini, stasionar nuqtalarini topish, o'sish va kamayish oraliqlarini aniqlash;
- 5) Funksiyaning ekstremumlarini topish;
- 6) Tekshirish natijalari bo'yicha funksiya grafigini yasash.

Grafikni aniqroq yasash uchun funksiyaning bir nechta nuqtalardagi qiymatlaridan ham foydalanish mumkin.

Masala.  $y = \frac{x^3}{3} + x^2 - 3x$  funksiyaning tekshirish va uning grafigini yasash.

1. Funksiyaning aniqlanish sohasi barcha haqiqiy sonlar to'plamidan iborat:  $x \in R$ .

2. Funksiya nollarini topamiz:

$$\frac{x^3}{3} + x^2 - 3x = 0 \Leftrightarrow x \left( \frac{x^2}{3} + x - 3 \right) = 0 \Rightarrow \begin{cases} x = 0 \\ x^2 + 3x - 9 = 0 \end{cases} \Rightarrow$$

$$\Rightarrow \begin{cases} x_1 = 0, \\ x_2 = -1,5 - 1,5\sqrt{5} \\ x_3 = -1,5 + 1,5\sqrt{5} \end{cases}$$

Shunday qilib, funksiya grafigi absissalar o'qi bilan  $0$ ,  $-1,5 - 1,5\sqrt{5}$  va  $-1,5 + 1,5\sqrt{5}$  nuqtalarda kesishadi.

3. Funksiyaning juft yoki toqligini aniqlaymiz:

$y(-x) = -\frac{x^3}{3} + x^2 + 3x = -\left(\frac{x^3}{3} - x^2 - 3x\right)$ , demak, funksiya toq ham emas, juft ham emas. Berilgan funksiya davriy funksiya emas.

4. Funksiyaning hosilasini, statsionar nuqtalarini, o'sish va kamayish oraliqlarini topamiz:

$$y' = x^2 + 2x - 3:$$

$$y' = 0: x^2 + 2x - 3 = 0 \Rightarrow \begin{cases} x_1 = -3, \\ x_2 = 1. \end{cases}$$

Topilgan statsionar nuqtalar sonlar o'qini  $(-\infty; -3)$ ,  $(-3; 1)$  va  $(1; +\infty)$  bo'lgan oraliqlarga bo'ladi. 175-rasmda funksiya hosilasi-



175-rasm

ning shu oraliqlardagi ishoralari ko'rsatilgan.

Funksiya  $(-\infty; -3)$  va  $(1; +\infty)$  oraliqlarda o'sadi,  $(-3; 1)$  oraliqda esa kamayadi.

5. Funksiya  $x = -3$  nuqtada maksimumga,  $x = 1$  nuqtada esa minimumga erishadi.

$$y_{\max}(-3) = \frac{(-3)^3}{3} + (-3)^2 - 3(-3) = -9 + 9 + 9 = 9;$$

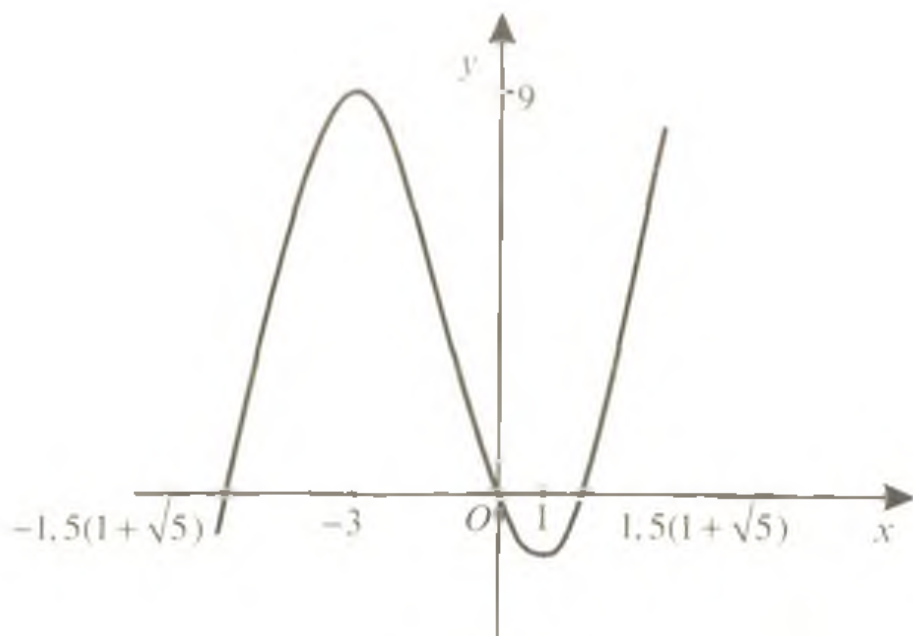

176-rasm

$$y_{\min}(1) = \frac{1}{3} + 1 - 3 = -1\frac{2}{3}.$$

Tekshirish natijalarini ushbu jadval ko'rinishida berish qulay:

$x$	$(-\infty; 3)$	$-3$	$(-3; 1)$	$1$	$(1; \infty)$	$-1,5(1+\sqrt{5})$	$0$	$1,5(-1+\sqrt{5})$
$f'(x)$	$+$	$0$	$-$	$0$	$+$			
$f''(x)$	o'sadi	$y_{\max} = 9$	kamayadi	$y_{\min} = -1\frac{2}{3}$	o'sadi	$0$	$0$	$0$

6. Funksiya grafigini yasashda jadvaldagi ma'lumotlardan tashqari  $f(-1,5) = 5\frac{5}{8}$  va  $f(3) = 9$  nuqtalarni ham olamiz. Funksiya grafigi 176-rasmda keltirilgan.

### 12-§. Funksiyaning eng katta va eng kichik qiymatlari

Ko'pgina amaliy masalalarni yechish kesmada uzluksiz bo'lgan funksiyaning eng katta va kichik qiymatlarini topishga keltiriladi.

Funksiyaning  $[a; b]$  kesmadagi eng katta va eng kichik qiymatini topish uchun funksiyaning  $(a; b)$  oraliqqa tegishli statsionar nuqtalarini topish, funksiyaning shu statsionar nuqtalardagi va kesmaning oxirlaridagi  $f(a), f(b)$  qiymatlarini hisoblash va topilgan qiymatlar orasida eng kattasini hamda eng kichigini tanlash kerak.

1-misol.  $y = 2x^3 - 3x^2 - 12x + 1$  funksiyaning  $[-2; 2,5]$  kesmadagi eng kichik va eng katta qiymatlarini toping.

Yechilishi. Funksiyaning hosilasini topamiz:  $y' = 6x^2 - 6x - 12$ . Topilgan hosilani nolga tenglashtirib,  $(-2; 2,5)$  oraliqqa tegishli statsionar nuqtalarni aniqlaymiz:

$$6x^2 - 6x - 12 = 0 \Leftrightarrow x^2 - x - 2 = 0 \Rightarrow \begin{cases} x_1 = 2, \\ x_2 = -1. \end{cases}$$

Statsionar nuqtalarning har ikkisi ham berilgan oraliqqa tegishli. Funksiyaning  $x = -1$ ;  $x = 2$  statsionar nuqtalardagi va kesmaning oxirlaridagi qiymatlarini hisoblaymiz:

$$f(-2) = 2 \cdot (-8) - 3 \cdot 4 - 12(-2) + 1 = -16 - 12 + 24 + 1 = -3;$$

$$f(-1) = -2 - 3 + 12 + 1 = 8;$$

$$f(2) = 16 - 12 - 24 + 1 = -19;$$

$$f(2,5) = \frac{125}{4} - \frac{75}{4} - 29 = -16,5.$$

Demak, berilgan funktsiyaning eng kichik qiymati  $-19$  ga, eng katta qiymati esa  $8$  ga teng.

Javob:  $-19; 8$ .

2-misol.  $y = x^2 \cdot \ln x$  funktsiyaning  $[1; e]$  kesmadagi eng kichik qiymatini toping.

Yechilishi. Funktsiyaning statsionar nuqtalarini topamiz:

$$y' = 2x \cdot \ln x + x^2 \cdot \frac{1}{x} = x(2 \ln x + 1) = 0 \Rightarrow \begin{cases} x_1 = 0, \\ x_2 = \frac{1}{\sqrt{e}}. \end{cases}$$

Topilgan statsionar nuqtalarning har ikkisi ham  $[1; e]$  kesmaga tegishli bo'lmaganligi sababli funktsiyaning faqat kesma oxirlaridagi qiymatlarini hisoblaymiz:

$$y(1) = 1 \cdot \ln 1 = 0; \quad y(e) = e^2 \cdot \ln e = e^2.$$

Shunday qilib,  $y(1) = 0$  funktsiyaning berilgan kesmadagi eng kichik qiymati,  $y(e) = e^2$  esa eng katta qiymatidir.

Javob:  $0$ .

Masala. Radiusi  $R$  ga teng bo'lgan aylanaga ichki chizilgan barcha to'g'ri to'rtburchaklar orasidan eng katta yuzaga ega bo'lganini toping.

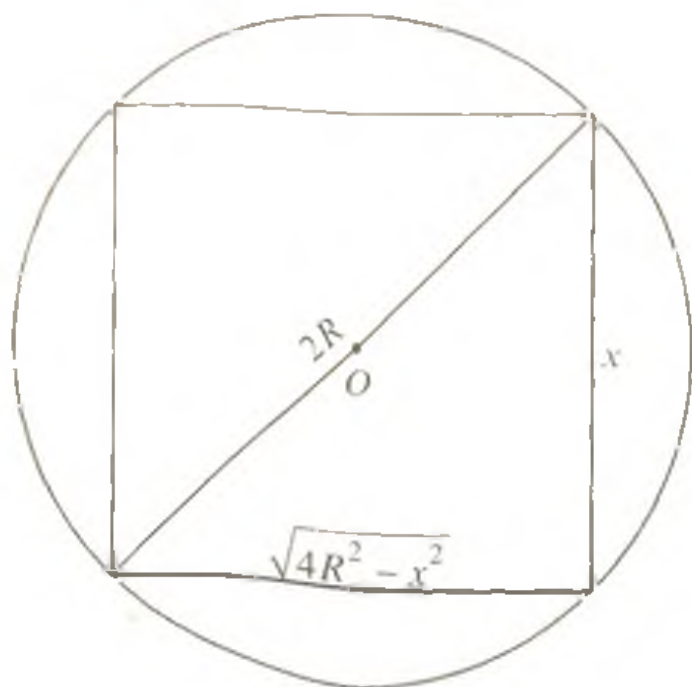

177-rasm

Y e c h i l i s h i .  
To'rtburchak tomonlaridan birini  $x$  deb belgilaymiz (177-rasm), u holda ikkinchi tomoni Pifagor teoremasiga ko'ra

$\sqrt{4R^2 - x^2}$  ga teng bo'ladi. Bunda

$0 < x < 2R$ . To'g'ri to'rtburchakning yuzi

$S(x) = x \cdot \sqrt{4R^2 - x^2}$  tenglik bilan ifodalanadi.

Masala  $x$  ning  $S(x)$  funksiya  $(0; 2R)$  oraliqdagi

eng katta qiymatga erishadigan qiymatini topishga keltirildi.  $S(x)$  funksiyaning  $(0; 2R)$  oraliqqa tegishli statsionar nuqtasini topamiz:

$$S'(x) = \sqrt{4R^2 - x^2} - \frac{x^2}{\sqrt{4R^2 - x^2}} = 0 \Leftrightarrow 4R^2 - 2x^2 = 0 \Leftrightarrow$$

$$\Leftrightarrow (\sqrt{2} \cdot R - x)(\sqrt{2} \cdot R + x) = 0.$$

$x = R\sqrt{2}$  statsionar nuqta  $(0; 2R)$  oraliqqa tegishli nuqta, bu nuqta funksiyaning maksimum nuqtasi. To'g'ri to'rtburchakning ikkinchi tomoni ham  $R\sqrt{2}$  ga teng:  $\sqrt{4R^2 - x^2} = R\sqrt{2}$ .

Shunday qilib, izlanayotgan to'g'ri to'rtburchak tomoni  $R\sqrt{2}$  teng bo'lgan kvadrat bo'lib, uning yuzi  $2R^2$  ga teng.

Javob: tomoni  $R\sqrt{2}$  ga teng kvadrat.

### 13-§. Ikkinchi tartibli hosila tushunchasi.

#### Yuqori tartibli hosilalar

$y = f(x)$  funksiya differentsiallanuvchi funksiya bo'lsin.  $f'(x)$  hosilaning qiymatlari, umuman aytganda,  $x$  ga bog'liq, ya'ni  $f'(x)$  hosila ham o'zgaruvchi  $x$  ning funksiyasidir:

$$f'(x) = \varphi(x).$$

Shu sababli hosilaning hosilasi to'g'risida gapirish mumkin.

**1-ta'rif.** Berilgan funksiya hosilasidan olingan hosila shu funksiyaning ikkinchi tartibli hosilasi yoki ikkinchi hosila deyiladi va  $y''$  yoki  $f''(x)$  kabi belgilanadi:

$$y'' = (y')' = f''(x).$$

1-misol.  $y = 3x^3 - 5x^2 + 7$  funksiyaning ikkinchi hosilasini toping.

Yechilishi.  $y' = (3x^3 - 5x^2 + 7)' = 9x^2 - 10x$ .

$$y'' = (y')' = (9x^2 - 10x)' = 18x - 10.$$

Javob:  $18x - 10$ .

2-misol.  $y = \cos^2 2x$  funksiya ikkinchi tartibli hosilasining  $x = \frac{\pi}{2}$  nuqtadagi qiymatini toping.

Yechilishi.  $y'(x) = (\cos^2 2x)' = -2 \cos 2x \cdot 2 \cdot \sin 2x = -2 \sin 4x$ ;

$$y''(x) = (-2 \sin 4x)' = -8 \cos 4x; \quad y''\left(\frac{\pi}{2}\right) = -8 \cos 2\pi = -8.$$

Javob:  $-8$ .



Ikkinchi tartibli hosilaning mexanik ma'nosi harakat tezlanishi-  
ni anglatishini eslatib o'tamiz(6-§).

**2-ta'rif.** *Ikkinchi tartibli hosiladan olingan hosila uchinchi tar-  
tibli hosila yoki uchinchi hosila deyiladi va  $y'''$  yoki  $f'''(x)$  kabi belgi-  
lanadi:*

$$y'''(x) = (y'')' = f'''(x).$$

**3-ta'rif.**  *$(n-1)$ - tartibli hosiladan olingan hosila  $n$ -tartibli hosila  
deyiladi va  $y^{(n)}$  yoki  $f^{(n)}(x)$  kabi belgilanadi:*

$$y^{(n)} = \left( y^{(n-1)} \right)' = f^{(n)}(x).$$

3-misol.  $y = 2^x$  funksiyaning 4-tartibli hosilasini toping.

Yechilishi.  $y' = (2^x)' = 2^x \ln 2$ ;  $y'' = (2^x \ln 2)' = 2^x \ln^2 2$ ;

$$y''' = (2^x \ln^2 2)' = 2^x \ln^3 2$$

$$y^{IV} = (2^x \ln^3 2)' = 2^x \ln^4 2.$$

Javob:  $2^x \ln^4 2$ .

#### **14-§. Ko'phadning koeffitsiyentlarini shu ko'phad hosilalarning qiymatlari orqali ifodalash**

Ushbu

$$P(x) = a_0 + a_1x + a_2x^2 + a_3x^3 + a_4x^4 + \dots + a_nx^n \quad (1)$$

ko'phad berilgan bo'lsin. U holda

$$P'(x) = 1 \cdot a_1 + 2 \cdot a_2x + 3 \cdot a_3x^2 + 4 \cdot a_4x^3 + \dots + n \cdot a_nx^{n-1};$$

$$P''(x) = 2 \cdot 1 \cdot a_2 + 3 \cdot 2 \cdot a_3x + 4 \cdot 3 \cdot a_4x^2 + \dots + n(n-1) \cdot a_nx^{n-2};$$

$$P'''(x) = 3 \cdot 2 \cdot 1 \cdot a_3 + 4 \cdot 3 \cdot 2 \cdot a_4x + \dots + n(n-1)(n-2) \cdot a_nx^{n-3};$$

.....

$$P^{(n)}(x) = n(n-1)(n-2) \cdot \dots \cdot 2 \cdot 1 \cdot a_n.$$

Qaralayotgan (1) ko'phadning va uning hosilalarining  $x = 0$  nuq-  
tadagi qiymatlarini hisoblab quyidagilarni hosil qilamiz:

$$P(0) = a_0, P'(0) = 1 \cdot a_1, P''(0) = 1 \cdot 2 \cdot a_2, P'''(0) = 1 \cdot 2 \cdot 3 \cdot a_3, \dots,$$

$$P^{(n)}(0) = 1 \cdot 2 \cdot 3 \cdot \dots \cdot (n-2)(n-1) \cdot n \cdot a_n.$$

Bulardan koeffitsiyentlarning qiymatlarini topamiz:

$$a_0 = P(0), a_1 = \frac{P'(0)}{1}, a_2 = \frac{P''(0)}{1 \cdot 2}, a_3 = \frac{P'''(0)}{1 \cdot 2 \cdot 3}, \dots, a_n = \frac{P^{(n)}(0)}{1 \cdot 2 \cdot 3 \cdot \dots \cdot n}. \quad (2)$$

Bu yerda  $1 \cdot 2 \cdot 3 \cdot \dots \cdot n$  ko'paytmani  $n!$  bilan belgilash qabul qilingan (en faktorial deb o'qiladi). Shuning uchun (2) da  $a_n$  ni quyidagicha yozish mumkin:

$$a_n = \frac{P^{(n)}(0)}{n!}. \quad (3)$$

Misol.  $(x+1)^{12}$  ko'phadning  $x^3$  qatnashgan hadi oldidagi koeffitsiyentini toping.

Yechilishi. Izlanayotgan koeffitsiyentni  $a_3$  deb belgilab, (3) formuladan foydalanamiz. Buning uchun berilgan ko'phadning uchinchi tartibli hosilasining  $x=0$  dagi qiymatini topamiz:

$$P'(x) = 12(x+1)^{11}; P''(x) = 12 \cdot 11(x+1)^{10};$$

$$P'''(x) = 12 \cdot 11 \cdot 10(x+1)^9; P'''(0) = 1320.$$

(3) formulaga ko'ra

$$a_3 = \frac{P'''(0)}{3!} = \frac{1320}{1 \cdot 2 \cdot 3} = 220.$$

Javob: 220.

### 15-§. Nyuton binomi

Bizga  $a+b$  ikki had ikkinchi va uchinchi darajalarining

$$(a+b)^2 = a^2 + 2ab + b^2, (a+b)^3 = a^3 + 3a^2b + 3ab^2 + b^3$$

formulalari ma'lum. Bu formulalar ushbu paragrafda keltirib chiqariladigan ixtiyoriy natural ko'rsatkichli  $(a+b)^n$  daraja formulasi-ning xususiy hollaridir.

$n$ -darajali  $P(x) = (x+a)^n$  ko'phadni qaraymiz, bunda  $a$  – berilgan biror son. Bu ko'phadning ozod hadi

$$a_n = P(0)$$

ga teng.  $x$  ning darajalari oldidagi koeffitsiyentlarni topish uchun oldingi paragrafdagi (3) formuladan foydalanamiz. Buning uchun  $P(x)$  ko'phadning hosilalarini topamiz:

$$P'(x) = n(x+a)^{n-1},$$

$$P''(x) = n(n-1)(x+a)^{n-2},$$

$$P'''(x) = n(n-1)(n-2)(x+a)^{n-3},$$

.....

$$P^{(k)}(x) = n(n-1)(n-2)\dots(n-k+1)(x+a)^{n-k}.$$

Topilgan hosilalarda  $x = 0$  desak,  $P(x) = (x+a)^n$  daraja ko'rsatkichning ko'phad shaklidagi yoyilmasidagi  $x$ ,  $x^2$ ,  $x^3$  va hokazo  $x^k$  ning

oldidagi koeffitsiyentlar mos ravishda  $na^{n-1}$ ,  $\frac{n(n-1)}{2!}a^{n-2}$ ,

$\frac{n(n-1)(n-2)}{3!}a^{n-3}$ , ...,  $\frac{n(n-1)(n-2)\dots(n-k+1)}{k!}a^{n-k}$  larga teng bo'ladi.

$\frac{n(n-1)(n-2)\dots(n-k+1)}{k!}$  ifodani  $C_n^k$  (o'qilishi: en dan ka tadan olingan  $C$ ) bilan belgilash qabul qilingan. Shuning uchun  $P(x)$  ko'phadning  $x^k$  oldidagi koeffitsiyentini  $C_n^k a^{n-k}$  deb yozib, ko'phadning o'zini

$$(x+a)^n = a^n + C_n^1 a^{n-1}x + C_n^2 a^{n-2}x^2 + \dots + C_n^{n-1} ax^{n-1} + C_n^n x^n$$

ko'rinishda yozish mumkin. Bu tenglikda  $x = b$  desak:

$$(a+b)^n = a^n + C_n^1 a^{n-1}b + C_n^2 a^{n-2}b^2 + \dots + C_n^{n-1} ab^{n-1} + C_n^n b^n. \quad (1)$$

(1) formula **Nyuton binomi** formulasi, undagi  $1, C_n^1, C_n^2, \dots, C_n^{n-1}, C_n^n$  koeffitsiyentlar **binomial koeffitsiyentlar** deyiladi.

Misol.  $(a+b)^4$  ni ko'phad shaklida yozing.

Yechilishi. (1) formuladan foydalanamiz:

$$(a+b)^4 = a^4 + C_4^1 a^3 b + C_4^2 a^2 b^2 + C_4^3 ab^3 + C_4^4 b^4.$$

$$C_4^1 = \frac{4}{1} = 4; C_4^2 = \frac{4 \cdot 3}{2!} = 6; C_4^3 = \frac{4 \cdot 3 \cdot 2}{3!} = 4; C_4^4 = \frac{4 \cdot 3 \cdot 2 \cdot 1}{4!} = 1.$$

$$(a+b)^4 = a^4 + 4a^3 b + 6a^2 b^2 + 4ab^3 + b^4.$$

Javob:  $a^4 + 4a^3 b + 6a^2 b^2 + 4ab^3 + b^4$ .

### Mustaqil ishlash uchun test topshiriqlari

1.  $\lim_{x \rightarrow \frac{1}{2}} \frac{8x^3 - 1}{6x^2 - 5x + 1}$  ni toping.

A) 0;      B) 1,2;      C) 4;      D) 5;      E) 6.

2.  $\lim_{x \rightarrow 1} \frac{(x-1)\sqrt{2-x}}{x^2-1}$  ni toping.

A) 0;      B)  $\frac{1}{2}$ ;      C)  $\frac{3}{4}$ ;      D) 1;      E) 2.

3.  $\lim_{x \rightarrow 1} \left( \frac{1}{1-x} - \frac{3}{1-x^3} \right)$  ni hisoblang.

A) -3;      B) -2;      C) -1;      D) 0;      E) 1.

4.  $\lim_{x \rightarrow \infty} \frac{x+1}{x}$  ni toping.

A) mavjud emas;      B) 1;      C) 0,5;      D) 1,5;      E) 5.

5.  $\lim_{x \rightarrow \infty} \frac{(x+1)^2}{2x^2}$  ni toping.

A) mavjud emas;      B) 0,5;      C) 1;      D) 1,5;      E) 2.

6.  $\lim_{x \rightarrow \infty} \frac{x^3 - 100x^2 + 1}{100x^2 + 15x}$  ni hisoblang.

A) mavjud emas;      B) -10;      C) 10;      D) -1;      E) 1.

7.  $\lim_{x \rightarrow 0} \frac{\sin 10x}{x}$  ni toping.

A) 0;      B)  $\frac{1}{2}$ ;      C)  $\frac{\sqrt{3}}{2}$ ;      D) 10;      E) 0,1.

8\*.  $\lim_{x \rightarrow 0} \frac{1 - \cos x}{x^2}$  ni toping.

A)  $\frac{1}{2}$ ;      B) 2;      C) 0;      D)  $-\frac{1}{2}$ ;      E) 1.

9\*.  $\lim_{x \rightarrow \infty} \left( \frac{x}{1+x} \right)^x$  ni toping.

A)  $e$ ;      B)  $e^{-1}$ ;      C)  $2e$ ;      D)  $e^{-2}$ ;      E) mavjud emas.

10\*.  $\lim_{x \rightarrow \infty} \left( 1 + \frac{1}{x} \right)^{x+1}$  ni toping.

A)  $e^2$ ;      B)  $e$ ;      C)  $e^{-1}$ ;      D) 1;      E) 2.

11.  $y = -\frac{3}{x}$  funksiya hosilasini toping.

A)  $-3$ ; B)  $3$ ; C)  $\frac{3}{x}$ ; D)  $\frac{3}{x^2}$ ; E)  $-3x$ .

12.  $f(x) = (x-5)(2x-5)$  bo'lsa,  $f'(5)$  ni toping.

A)  $0$ ; B)  $10$ ; C)  $5$ ; D)  $12$ ; E)  $7$ .

13.  $f(x) = 2\sqrt{x} - \frac{1}{x} + \sqrt[3]{3}$  funksiya hosilasini toping.

A)  $2 - \frac{1}{x^2}$ ; B)  $\frac{1}{2\sqrt{x}} - \frac{1}{x}$ ; C)  $\frac{1}{\sqrt{x}} + \frac{1}{x^2}$ ;

D)  $\frac{\sqrt{x}+1}{x^2}$ ; E)  $\frac{x\sqrt{x}+2}{2x^2}$ .

14.  $f(x) = 3x - 2\sqrt{x}$ ,  $f'(4)$ ?

A)  $2,5$ ; B)  $2$ ; C)  $\frac{\sqrt{2}}{2}$ ; D)  $3$ ; E)  $1$ .

15.  $y = \frac{x}{x^2+1}$  funksiyaning  $x = 1$  nuqtadagi hosilasini toping.

A)  $0$ ; B)  $\frac{1}{4}$ ; C)  $1$ ; D)  $\frac{1}{2}$ ; E)  $-1$ .

16.  $y = \frac{1+x}{\sqrt{1-x}}$  funksiyaning hosilasini toping.

A)  $-\frac{x}{\sqrt{(1-x)^3}}$ ; B)  $-\frac{x}{2\sqrt{(1-x)^3}}$ ; C)  $\frac{2x}{(1-x)\sqrt{1-x}}$ ;

D)  $-\frac{3-2x}{(1-x)\sqrt{1-x}}$ ; E)  $\frac{3-2x}{2(1-x)\sqrt{1-x}}$ .

17.  $y = \sqrt[3]{\frac{1}{1+x^3}}$  funksiyaning hosilasini toping.

A)  $-\frac{2x}{3(1+x^2)^3\sqrt{1+x^2}}$ ; B)  $\frac{2x}{3(1+x^2)^3\sqrt{1+x^2}}$ ; C)  $\frac{2x}{3(1+x^2)^2\sqrt[3]{(1+x^2)^2}}$ ;

D)  $-\frac{2x}{3(1+x^2)^2\sqrt[3]{(1+x^2)^2}}$ ; E)  $\frac{2x}{3\sqrt[3]{(1+x^2)^2}}$ .

18.  $y = \sin x + \cos x$  funksiyaning hosilasini toping.

- A)  $\cos x + \sin x$ ;      B)  $\cos x - \sin x$ ;  
C)  $-(\cos x - \sin x)$ ;      D) 0;      E) 1.

19.  $y = x \sin x + \cos x$  funksiyaning hosilasini toping.

- A)  $x \cos x - \sin x$ ;      B)  $\sin x + \cos x$ ;  
C)  $x \cos x$ ;      D)  $x \sin x$ ;      E)  $\sin x - \cos x$ .

20.  $y = \operatorname{tg} x + \operatorname{ctg} x$  funksiyaning hosilasini toping.

- A)  $\frac{1}{\cos^2 x \sin^2 x}$ ;      B)  $\operatorname{tg}^2 x$ ;      C)  $\operatorname{ctg}^2 x$ ;  
D) 1;      E) 0.

21.  $y = \sin x \cdot \cos x$  funksiya hosilasining  $x = \frac{\pi}{2}$  nuqtadagi qiymatini toping.

- A) 0;      B) -1;      C)  $\frac{1}{2}$ ;      D)  $-\frac{1}{2}$ ;      E) 2.

22.  $y = \frac{1}{4} \operatorname{tg}^4 x$  funksiyaning hosilasini toping.

- A)  $\frac{1}{4 \cos^4 x}$ ;      B)  $\operatorname{tg}^3 x$ ;      C)  $\frac{\sin x}{\cos^3 x}$ ;      D)  $\frac{\sin^3 x}{\cos^3 x}$ ;      E)  $\frac{\sin^2 x}{\cos^3 x}$ .

23\*.  $y = \frac{1}{3} \operatorname{tg}^3 x - \operatorname{tg} x + x$  funksiyaning hosilasini toping.

- A)  $\operatorname{tg}^4 x$ ;      B)  $\operatorname{tg}^2 x - \frac{1}{\cos^2 x} + 1$ ;      C)  $\operatorname{tg}^2 x - \operatorname{ctg} x + 1$ ;

- D)  $\operatorname{ctg}^2 x - \operatorname{tg} x + 1$ ;      E)  $\operatorname{tg}^2 x + \frac{1}{\sin^2 x} + 1$ .

24.  $y = \frac{\sin x}{1 + \cos x}$  funksiya hosilasining  $x = \frac{\pi}{2}$  nuqtadagi qiymatini toping.

- A) -1;      B)  $\frac{\sqrt{2}}{2}$ ;      C)  $\frac{1}{2}$ ;      D)  $\frac{1}{4}$ ;      E) 1.

25.  $y = \operatorname{tg}^{\frac{x+1}{2}}$  funksiyaning hosilasini toping.

- A)  $\frac{1}{\cos^{2x+1}}$ ;      B)  $-\frac{1}{\cos^{2x+1}}$ ;      C)  $\frac{2}{\cos^{2x+1}}$ ;

$$D) \frac{1}{2\cos^2 x + 1}; \quad E) \frac{1}{2\sin^2 x + 1}.$$

26.  $y = \sin(\sin x)$  funksiyaning hosilasini toping.

A)  $\cos(\sin x) \cdot \cos x$ ;      B)  $\cos(\sin x)$ ;      C)  $-\cos(\sin x)$ ;  
D)  $\cos x$ ;      E)  $\cos^2 x$ .

27\*.  $f(x) = (1 + \sin^2 x)^4$ ;  $f'(\pi)$ ;  $f''(\pi)$ ?

A) 2;      B) 4;      C) -4;      D) 0;      E) 8.

28\*.  $y_1 = \cos^2 3x$ ;  $y_2 = -\sin^2 3x$  va  $y_3 = 2\sin 6x$  funksiyalardan qaysilarining hosilalari teng?

A)  $y_1$ ;  $y_3$ ;      B)  $y_1$ ;  $y_2$ ;      C)  $y_1$ ;  $y_2$ ;  $y_3$ ;      D)  $y_2$ ;  $y_3$ ;  
E) hosilasi tenglari yo'q.

29.  $y = x \cdot \arcsin x$  funksiyaning hosilasini toping.

A)  $\arcsin x$ ;      B)  $1 + \frac{1}{\sqrt{1-x^2}}$ ;      C)  $1 + \arccos x$ ;

D)  $\arccos x$ ;      E)  $\arcsin x + \frac{x}{\sqrt{1-x^2}}$ .

30.  $y = (\arccos x)^2$  funksiyaning hosilasini toping.

A)  $2 \arccos x$ ;      B)  $-\frac{2\arccos x}{\sqrt{1-x^2}}$ ;      C)  $2 \arcsin x$ ;

D)  $\frac{2\arcsin x}{\sqrt{1-x^2}}$ ;      E)  $(\arcsin x)^2$ .

31.  $y = \operatorname{arctg} \frac{x}{2}$  funksiyaning hosilasini toping.

A)  $\frac{2}{4+x^2}$ ;      B)  $-\frac{2}{4+x^2}$ ;      C)  $\operatorname{arctg} \frac{x}{2}$ ;      D)  $\frac{1}{2} \operatorname{arctg} \frac{x}{2}$ ;

E)  $\frac{4}{4+x^2}$ .

32.  $y = \operatorname{arctg} x^2$  funksiyaning hosilasini toping.

A)  $-\operatorname{arctg} x^2$ ;      B)  $2x \operatorname{arctg} x^2$ ;      C)  $\frac{2x}{1+x^4}$ ;

D)  $\frac{1}{1+x^4}$ ;      E)  $-\frac{2x}{1+x^2}$ .

33\*.  $y = \arcsin(\sin x)$  funksiyaning hosilasini toping.

A)  $\arccos(\sin x)$ ;      B)  $\frac{1}{\sqrt{1-\sin^2 x}}$ ;      C)  $-\frac{1}{|\cos x|}$ ;

D)  $\frac{\cos x}{|\cos x|}$ ;      E) 1.

34.  $y = 10^x$  funksiyaning hosilasini toping.

A)  $x \cdot 10^{x-1}$ ;      B)  $\frac{10^x}{\ln 10}$ ;      C)  $10^x \ln 10$ ;      D)  $10^x \cdot 10$ ;      E)  $\ln 10^x$ .

35.  $y = \frac{1}{3^x}$  funksiyaning hosilasini toping.

A)  $-\frac{x}{3^{x+1}}$ ;      B)  $-\frac{\ln 3}{3^x}$ ;      C)  $\frac{1}{3^{2x}}$ ;      D)  $\frac{\ln 3}{3^{2x}}$ ;      E)  $\frac{\ln 3}{3^{x+2}}$ .

36.  $y = x \cdot e^x$  funksiya hosilasining  $x = 1$  nuqtadagi qiymatini toping.

A)  $2e$ ;      B)  $e$ ;      C) 2;      D) 1      E)  $3e$ .

37.  $y = 3^{\sin x}$  funksiyaning hosilasini toping.

A)  $3^{\cos x}$ ;      B)  $3^{\cos x} \ln 3$ ;      C)  $\cos x \cdot 3^{\sin x} \ln 3$ ;  
D)  $3^{\sin x} \ln 3$ ;      E)  $\sin x \cdot 3^{\sin x - 1}$ .

38.  $y = x^2 \log_3 x$  funksiyaning hosilasini toping.

A)  $2x \log_3 x$ ;      B)  $2x \log_3 x + x$ ;      C)  $2x \log_3 x + \frac{1}{x}$ ;

D)  $2x \log_3 x + \frac{1}{\ln 3}$ ;      E)  $2x \log_3 x + \frac{x}{\ln 3}$ .

39.  $y = \ln^2 x$  funksiyaning hosilasini toping.

A)  $\frac{2 \ln x}{x}$ ;      B)  $2 \ln x$ ;      C)  $\frac{1}{x^2}$ ;

D)  $\frac{\ln x}{x^2}$ ;      E)  $\frac{\ln^3 x}{3}$ .

40.  $f(x) = \ln \operatorname{tg} x$ .  $f'\left(\frac{\pi}{4}\right)$ ?

A) 0;      B) 1;      C)  $\frac{\sqrt{2}}{2}$ ;      D) 2;      E)  $\frac{1}{2}$ .

41\*.  $y = \ln \frac{1-e^x}{e^x}$  funksiyaning hosilasini toping.



A)  $\frac{e^x}{1-e^x}$ ; B)  $\frac{1}{e^x-1}$ ; C)  $\frac{1}{1-e^x}$ ; D)  $\frac{1}{e^x}$ ; E)  $\frac{e^x}{e^x-1}$ .

42\*.  $y = \sqrt{\frac{2x-1}{3}} + \ln \frac{2x+3}{5}$  funksiyaning hosilasini toping.

A)  $\frac{1}{\sqrt{6x-3}} + \frac{2}{2x+3}$ ; B)  $\sqrt{\frac{3}{2x-1}} + \frac{5}{2x+3}$ ; C)  $\frac{2(2x-1)}{3} + \frac{2}{5}$ ;

D)  $\sqrt{\frac{2}{3}} + \frac{2}{5}$ ; E)  $\frac{6-\sqrt{2x-1}}{3} + \frac{5}{2x+3}$ .

43\*.  $y = 2 \cdot e^{\frac{1-x}{3}} + 3 \cos \frac{1-x}{2}$  funksiyaning hosilasini toping.

A)  $\frac{3}{2} \sin \frac{1-x}{2} - \frac{2}{3} e^{\frac{1-x}{3}}$ ; B)  $2 \cdot e^{\frac{1-x}{3}} + 3 \sin \frac{1-x}{2}$ ;

C)  $2 \cdot e^{\frac{1-x}{3}} - 3 \sin \frac{1-x}{2}$ ; D)  $2 \cdot e^{-\frac{1-x}{9}} + 3 \sin \frac{2+x}{4}$ ;

E)  $\frac{3}{2} \sin \frac{1-x}{2} + \frac{2}{3} e^{\frac{1-x}{3}}$ .

44\*.  $y = \ln(1-3x) \cdot \sin x$  funksiyaning hosilasini toping.

A)  $\frac{\sin x}{1-3x} + \ln(1-3x) - \cos x$ ; B)  $\frac{3 \sin x}{3x-1} + \ln(1-3x) \cdot \cos x$ ;

C)  $\frac{\cos x}{1-3x}$ ; D)  $\frac{3 \sin x}{1-3x} + \ln(1-3x) \cdot \cos x$ ; E)  $-\frac{3 \cos x}{1-3x}$ .

45\*.  $y = 0,5^x \cdot \sin 2x$  funksiyaning hosilasini toping.

A)  $(x-1)0,5^x \cos 2x$ ; B)  $x \cdot 0,5^{x-1} \cos 2x$ ;

C)  $2x \cdot 0,5^{x-1} \cos 2x$ ; D)  $0,5^x (\ln \cdot 0,5 \sin 2x + 2 \cos 2x)$ ;

E)  $0,5^x \ln 2 + 2 \cos 2x$ .

46.  $y = \frac{1}{x}$  funksiya grafigiga  $x_0 = 1$  absissali nuqtada o'tkazilgan urinma bilan  $Ox$  o'qi orasidagi burchakni toping.

A)  $30^\circ$ ; B)  $45^\circ$ ; C)  $60^\circ$ ; D)  $120^\circ$ ; E)  $135^\circ$ .

47.  $y = \ln(2x+1)$  funksiya grafigiga  $x_0 = 2$  absissali nuqtada o'tkazilgan urinmaning  $Ox$  o'qining musbat yo'nalishi bilan tashkil etgan burchagini toping.

A)  $\arctg 0,4$ ; B)  $45^\circ$ ; C)  $\arctg 0,2$ ;

D)  $\arctg 0,5$ ; E)  $\arctg 2$ .

48.  $f(x) = x^2 + \sin x$  funksiya grafigiga  $x = 0$  absissali nuqtada o'tkazilgan urinma bilan  $Oy$  o'qi orasidagi burchakni toping.

A)  $30^\circ$ ; B)  $45^\circ$ ; C)  $60^\circ$ ; D)  $120^\circ$ ; E)  $150^\circ$ .

49\*.  $f(x) = \sqrt{x+1} + e^x$  funksiya grafigiga  $x = 0$  absissali nuqtada o'tkazilgan urinma bilan  $Oy$  o'qi orasidagi burchakni toping.

A)  $0^\circ$ ; B)  $30^\circ$ ; C)  $45^\circ$ ; D)  $60^\circ$ ; E)  $90^\circ$ .

50\*.  $f(x) = 3x^2 + 7x + 1$  parabolaning qaysi nuqtasida o'tkazilgan urinma absissalar o'qi bilan  $\frac{\pi}{4}$  burchak hosil qiladi?

A) (0; 1); B) (-2; -1); C) (1; 11); D) (-3; 7); E) (-1; -3).

51\*.  $f(x) = x^3 - x - 1$  va  $\varphi(x) = 3x^2 - 4x + 1$  egri chiziq'larga o'tkazilgan urinmalar parallel bo'ladigan nuqtalar koordinatalarini toping.

A) (1; 1); B) (1; 0); C) (0; 1); D) (1; -1) va (1; 0);

E) (1; 1) va (0; 1).

52.  $f(x) = x^3 + 3x$  funksiya grafigiga  $x_0 = 2$  absissali nuqtada o'tkazilgan urinma tenglamasini yozing.

A)  $y = 30x - 54$ ; B)  $y = 15x - 16$ ; C)  $y = 6x + 8$ ;

D)  $y = 15x + 16$ ; E)  $y = 30x + 54$ .

53.  $f(x) = \operatorname{tg} x$  funksiya grafigiga  $x_0 = \frac{\pi}{3}$  absissali nuqtada o'tkazilgan urinma tenglamasini ko'rsating.

A)  $y = 4x + \sqrt{3} - \frac{\pi}{4}$ ; B)  $y = 4x - 0,5$ ; C)  $y = 4x - \frac{\sqrt{3}}{4}$ ;

D)  $y = 4x + \sqrt{3} - \frac{3}{4}$ ; E)  $y = 4x + \sqrt{3}$ .

54.  $y = 1 - e^x$  funksiya grafigiga uning  $Oy$  o'qi bilan kesishish nuqtasida o'tkazilgan urinma tenglamasini ko'rsating.

A)  $y = -\frac{1}{2}x$ ; B)  $y = \frac{1}{2}x$ ; C)  $y = 1$ ; D)  $y \neq -1$ ; E)  $y = \frac{1}{2}x - \frac{1}{2}$ .

55\*.  $f(x) = (x - 0,5)^2 + 1,5$  funksiya grafigiga o'tkazilgan urinma  $y = 3x + 7$  to'g'ri chiziqqa parallel bo'lgan urinish nuqtasidan koordinata boshigacha bo'lgan masofani toping.

A) 4,25; B) 3,75; C) 5,5; D) 6,85; E) 4,75.

56. Moddiy nuqta to'g'ri chiziq bo'ylab  $S(t) = 6t^3 - 2t^2 + 5$  qonuniyat bilan harakatlanyapti. Harakat boshlangandan 1 s o'tgach, uning tezligi qanday bo'lishini aniqlang.

A) 32 m/s; B) 9 m/s; C) 14 m/s; D) 40 m/s; E) 22 m/s.

57. Ikki moddiy nuqta  $S_1(t) = 2,5t^2 - 6t + 1$  va  $S_2(t) = 0,5t^2 + 2t - 3$  qonuniyat bo'yicha harakatlanyapti. Qaysi vaqtda birinchi nuqtaning tezligi ikkinchisidan uch marta ko'p bo'ladi?

A) 2; B) 3; C) 4; D) 5; E) 6.

58. Moddiy nuqta  $S(t) = -\frac{1}{6}t^3 + 3t^2 - 5$  qonuniyat bo'yicha harakatlanayapti. Uning tezlanishi nolga teng bo'lganda, tezligi qancha-ga teng bo'ladi?

A) 24; B) 18; C) 12; D) 6; E) 15.

59. To'g'ri chiziq bo'ylab harakatlanayotgan nuqtaning tezligi  $v(t) = \ln t - \frac{1}{8}t$  (m/s) qonuniyat bo'yicha o'zgaradi. Vaqtning qanday momentida (s) uning tezlanishi nolga teng bo'ladi?

A) 6; B) 7; C) 8; D) 9; E) 5.

60.  $y = x^4 - 2x^2$  funksiyaning o'sish oraliqlarini toping.

A)  $[-1; 1]$ ; B)  $(-\infty; -1)$ ; C)  $[-1; 0] \cup [2; +\infty]$ ;

D)  $(-\infty; +\infty)$ ; E)  $[0; +\infty)$ .

61.  $y = 1 + \frac{2}{x}$  funksiyaning kamayish oraliqlarini ko'rsating.

A)  $(-\infty; 0) \cup (0; +\infty)$ ; B)  $(-\infty; +\infty)$ ; C)  $(-\infty; 0)$ ;

D)  $(0; +\infty)$ ; E)  $[1; 2]$ .

62\*.  $y = ax - \sin x$  funksiya  $a$  ning qanday qiymatlarida sonlar o'qining barcha nuqtalarida o'sadi?

A)  $a \in (-\infty; -1]$ ; B)  $a \in (-\infty; -1)$ ; C)  $a \in [-1; +\infty)$ ;

D)  $a \in [1; +\infty)$ ; E)  $a \in (1; +\infty)$ .

63\*.  $k$  ning qanday qiymatlarida  $y = \cos x + kx$  funksiya aniqlanish sohasida kamayadi?

- A)  $k \in (-\infty; 1)$ ;      B)  $k \in (-1; +\infty)$ ; C)  $k \in [-1; +\infty)$ ;  
 D)  $k \in (-\infty; -1]$ ;      E)  $k \in [-1; 1]$ .

64\*.  $y = \ln(4x - x^2)$  funksiyaning kamayish oralig'ini ko'rsating.

- A)  $[2; 4)$ ;    B)  $(0; 2)$ ;    C)  $(2; +\infty)$ ; D)  $(-\infty; 0)$ ; E)  $(0; 4)$ .

65\*. Agar  $p$  o'zgarmas son ( $p > 0$ ) bo'lsa,  $p$  ning qanday qiymatlarida  $y = px - \ln x$  funksiya  $(0; 8]$  oraliqda kamayuvchi bo'ladi?

- A)  $\frac{1}{8}$ ;    B)  $\frac{1}{4}$ ;    C)  $\frac{3}{5}$ ;    D)  $\frac{1}{7}$ ;    E)  $1\frac{1}{6}$ .

66\*.  $y = \frac{x}{\ln x}$  funksiyaning o'sish oralig'ini ko'rsating

- A)  $(0; 1)$ ;    B)  $(1; \infty)$ ;    C)  $(1; e)$ ; D)  $(e; +\infty)$ ; E)  $(0; e)$ .

67.  $y = x^3 - 3x + 1$  funksiyaning maksimumini toping.

- A)  $-1$ ;    B)  $1$ ;    C)  $2$ ;    D)  $4$ ;    E)  $3$ .

68.  $y = \frac{x}{1+x^2}$  funksiyaning minimum nuqtasidagi qiymatini toping.

- A)  $\frac{1}{2}$ ;    B)  $2$ ;    C)  $-\frac{1}{2}$ ;    D)  $-2$ ;    E)  $-1$ .

69.  $y = x^3 - x$  funksiyaning minimum va maksimum nuqtalaridagi qiymatlari yig'indisini toping.

- A)  $4\sqrt{3}$ ;    B)  $\frac{2}{9}$ ;    C)  $0$ ;    D)  $-\sqrt{3}$ ;    E)  $\sqrt{3}$ .

70.  $y = \frac{(x-1)^2+1}{x-1}$  funksiyaning maksimum nuqtasidagi qiymatini toping.

- A)  $-1$ ;    B)  $2$ ;    C)  $-2$ ;    D)  $0$ ;    E)  $-\frac{1}{2}$ .

71.  $y = 3x^5 - 5x^3 - 3$  funksiyaning ekstremum nuqtalardagi qiymatlari yig'indisini toping.

- A)  $-6$ ;    B)  $-8$ ;    C)  $-9$ ;    D)  $-2$ ;    E)  $-4$ .

72.  $y = -\frac{x^3}{3} + 2x^2 - 3x$  funksiyaning maksimum va minimumlari ayirmasini toping.

- A)  $1\frac{1}{3}$ ;    B)  $-1\frac{1}{3}$ ;    C)  $0$ ;    D)  $1.5$ ;    E)  $-1.5$ .

73.  $f(x) = x^3 - 3x^2$  funksiyaning  $[1; 3]$  kesmadagi eng katta va eng kichik qiymatlari nisbatini toping.

- A)  $-2$ ; B)  $\frac{1}{2}$ ; C)  $0$ ; D)  $2$ ; E)  $-\frac{1}{2}$ .

74.  $f(x) = x + \sqrt{x}$  funksiyaning  $[0; 4]$  kesmadagi eng katta qiymatini toping.

- A)  $0$ ; B)  $16$ ; C)  $8$ ; D)  $6$ ; E)  $18$ .

75.  $f(x) = x - 2 \ln x$  funksiyaning  $[1; e]$  kesmadagi eng kichik qiymatini toping.

- A)  $0$ ; B)  $1$ ; C)  $2(1 - \ln 2)$ ; D)  $e - 2$ ; E)  $-1$ .

76.  $f(x) = 2 \sin x + \sin 2x$  funksiyaning  $\left[0; \frac{3\pi}{2}\right]$  kesmadagi eng kichik qiymatini ko'rsating.

- A)  $0$ ; B)  $-2$ ; C)  $-3$ ; D)  $-1.5\sqrt{3}$ ; E)  $-3\sqrt{3}$ .

77.  $y = \frac{x}{2} + \sin^2 x$  funksiyaning  $\left[-\frac{\pi}{2}; \frac{\pi}{2}\right]$  kesmadagi eng katta qiymatini toping.

- A)  $-\frac{\pi}{2} + 1$ ; B)  $-\frac{\pi}{4} + 1$ ; C)  $\frac{\pi}{6} + 1$ ; D)  $\frac{\pi}{2} + 1$ ; E)  $\frac{\pi}{4} + 1$ .

78.  $y = x \ln x - x \ln 5$  funksiyaning  $[1; 5]$  kesmadagi eng kichik qiymatini ko'rsating.

- A)  $-\frac{5}{e}$ ; B)  $-\ln 5$ ; C)  $\frac{5}{e}$ ; D)  $-\ln \frac{5}{e}$ ; E)  $0$ .

79.  $y = \sin 2x + 2 \cos x$  funksiyaning  $\left[\frac{\pi}{2}; \pi\right]$  kesmadagi eng kichik qiymatini toping.

- A)  $-2$ ; B)  $0$ ; C)  $-3$ ; D)  $-1.5\sqrt{3}$ ; E)  $-0.5\sqrt{3}$ .

80\*. To'la sirtining yuzi  $600 \text{ sm}^2$  ga teng bo'lgan barcha muntazam to'g'ri to'rtburchakli parallelepipedlar orasida eng katta hajmli parallelepipedni toping.

- A)  $1000 \text{ sm}^3$  li; B)  $1600 \text{ sm}^3$  li; C)  $900 \text{ sm}^3$  li; D)  $2500 \text{ sm}^3$  li; E)  $400 \text{ sm}^3$  li.

81\*. Tomonlarining uzunliklari  $0,8 \text{ m}$  va  $0,5 \text{ m}$  bo'lgan to'g'ri to'rtburchakli tunukaning burchaklaridan kvadratlar kesib olib, hosil bo'lgan chetlarini buklab yasaladigan usti ochiq idishning eng katta hajmini toping.

A)  $0,4 \text{ m}^3$ ; B)  $0,16 \text{ m}^3$ ; C)  $0,016 \text{ m}^3$ ; D)  $0,018 \text{ m}^3$ ; E)  $0,02 \text{ m}^3$ .

82\*. Asosi kvadratdan iborat, hajmi  $32 \text{ m}^3$  ga teng bo'lgan hovuzning yon sirti va asosini suv o'tkazmaydigan materialdan eng kam miqdorda sarflab qoplash uchun hovuz o'lchamlari qanday bo'lishi kerak?

A)  $4 \times 4 \times 2$ ; B)  $1 \times 1 \times 32$ ; C)  $2 \times 2 \times 8$ ; D)  $8 \times 8 \times 0,5$ ;  
E)  $5 \times 5 \times 1,28 \text{ m}$ .

83. Bir tomondan imorat bilan chegaralangan, qolgan tomonlari uzunligi  $80 \text{ m}$  panjara bilan o'ralgan to'g'ri to'rtburchak shaklidagi yer maydonining eng katta yuzini toping.

A) 1600; B) 1200; C) 1000; D) 800; E) 600  $\text{m}^2$ .

84.  $(x + 2)^{10}$  ko'phadning  $x^4$  qatnashgan hadi oldidagi ko'effitsiyentini toping.

A) 13440; B) 1200; C) 13200; D) 16400; E) 5040.

BOSHLANG'ICH FUNKSIYA VA INTEGRAL

1-§. Boshlang'ich funksiya. Aniqmas integral

**1.1. Boshlang'ich funksiya tushunchasi.** Agar to'g'ri chiziq bo'ylab harakatlanayotgan moddiy nuqtaning  $s(t)$  harakat qonuni ma'lum bo'lsa, u holda  $v(t)$  oniy tezlik  $s(t)$  funksiyaning hosilasiga tengligini bilamiz, ya'ni

$$v(t) = s'(t).$$

Amaliyotda teskari masala ham uchraydi: harakatlanayotgan nuqtaning  $v(t)$  tezligini bilgan holda uning harakatlanish qonunini toping, ya'ni shunday  $s(t)$  funksiyaning topish kerakki, uning hosilasi  $v(t)$  ga teng bo'lsin.  $s'(t) = v(t)$  bo'lgan bunday  $s(t)$  funksiyaning  $v(t)$  funksiyaning **boshlang'ich funksiyasi** deyiladi.

Masalan, agar  $v(t) = kt$  (bunda  $k$  – berilgan son) bo'lsa, u holda  $s(t) = \frac{kt^2}{2}$  funksiya  $v(t)$  funksiyaning boshlang'ich funksiyasi bo'ladi, chunki

$$s'(t) = \left( \frac{kt^2}{2} \right)' = \frac{2kt}{2} = kt = v(t).$$

**Ta'rif.** *Biror oraliqdagi barcha  $x$  lar uchun  $F'(x) = f(x)$  tenglik bajarilsa,  $F(x)$  funksiya shu oraliqda  $f(x)$  funksiyaning boshlang'ich funksiyasi deyiladi.*

Masalan,  $(x^4)' = 4x^3$  tenglikdan  $F(x) = x^4$  funksiya butun sonlar o'qida  $f(x) = 4x^3$  funksiyaning boshlang'ich funksiyasi ekanligi,  $(\cos x)' = -\sin x$  tenglikdan esa  $F(x) = -\cos x$  funksiya  $f(x) = \sin x$  funksiyaning boshlang'ich funksiyasi ekanligi kelib chiqadi.

Berilgan funksiyaning boshlang'ich funksiyasini topish masalasi bir qiymatli hal qilinmaydi. Haqiqatan ham, agar  $F(x)$  funksiya  $f(x)$  ning boshlang'ich funksiyasi bo'lsa, u holda  $F(x) + C$  funksiya ham (bunda  $C$  – ixtiyoriy o'zgarmas son)  $f(x)$  funksiyaning boshlang'ich funksiyasi bo'ladi, chunki  $C$  ning istalgan qiymati uchun  $(F(x) + C)' = f(x)$  bo'ladi.

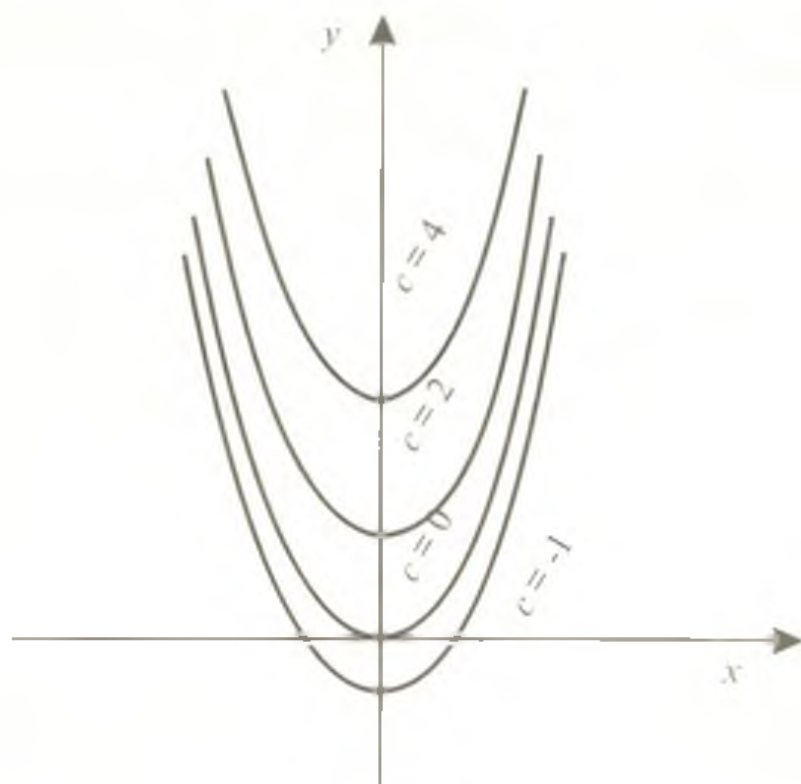

178-rasm

Masalan, yuqorida keltirilgan misolda  $F(x) = x^4$  funksiyagina emas, balki barcha  $F(x) = x^4 + C$  funksiyalar to'plami ham  $f(x) = 4x^3$  funksiyaning boshlang'ich funksiyalari bo'ladi, chunki,

$$(x^4 + C)' = 4x^3.$$

Shunga o'xshash,  $f(x) = 2x$  funksiyaning boshlang'ich funksiyalar to'plami  $F(x) = x^2 + C$  – parabolalar to'plami bo'lib, bu to'plamni ixtiyoriy  $C$  ga turli qiymatlar berib hosil qilish mumkin (178-rasm).

Ixtiyoriy o'zgarmas  $C$  ni tanlash bilan boshlang'ich funksiya grafigini berilgan nuqta orqali o'tishiga erishish mumkin.

Masalan,  $f(x) = 3x^2$  funksiyaning  $(-1; 2)$  nuqtadan o'tuvchi boshlang'ich funksiyasini topish kerak bo'lsin. Berilgan funksiyaning boshlang'ich funksiyasi  $F(x) = x^3 + C$ , chunki  $(x^3 + C)' = 3x^2$ . Shunday  $C$  ni topamizki,  $y = x^3 + C$  funksiyaning grafigi  $(-1; 2)$  nuqtadan o'tsin.  $x = -1; y = 2$  larni qo'yib,  $2 = -1 + C$  ni hosil qilamiz. Bundan  $C = 3$ , demak,

$$F(x) = x^3 + 3.$$

**1.2. Aniqmas integral.** Berilgan funksiyaning hosilasini topish amali differensiallash deb atalishini eslatib o'tamiz.

**Ta'rif.** Agar  $F(x)$  funksiya biror oraliqda  $f(x)$  funksiyaning boshlang'ich funksiyasi bo'lsa, u holda  $F(x) + C$  (bunda  $C$  – ixtiyoriy



*o'zgarmas*) funksiyalar to'plami shu oraliqda  $f(x)$  funksiyaning **aniqmas integrali** deyiladi va

$$\int f(x)dx = F(x) + C$$

kabi belgilanadi. Bu yerda  $f(x)$  – *integral ostidagi funksiya*,  $x$  – *integrallash o'zgaruvchisi*,  $\int$  – *integral belgisi*,  $f(x)dx$  *integral ostidagi ifoda*,  $C$  – *integrallash doimiysi* deyiladi. Biror oraliqda uzluksiz bo'lgan istalgan funksiya shu oraliqda boshlang'ich funksiyaga ega, demak, aniqmas integralga ham ega ekanini eslatib o'tamiz.

1-misol.  $\int \cos x dx = \sin x + C$ , chunki  $(\sin x)' = \cos x$ .

2-misol.  $\int \frac{1}{\cos^2 x} dx = \operatorname{tg} x + C$ , chunki  $(\operatorname{tg} x)' = \frac{1}{\cos^2 x}$ .

3-misol.  $\int 5x^4 dx = x^5 + C$ , chunki  $(x^5)' = 5x^4$ .

Aniqmas integralning quyidagi asosiy xossalarini keltiramiz.

1. Aniqmas integralning hosilasi integral ostidagi funksiyaga teng, ya'ni

$$\left( \int f(x)dx \right)' = f(x).$$

2. Bir necha funksiyalarning algebraik yig'indisidan olingan integral qo'shiluvchi funksiyalar integrallari yig'indisiga teng.

3. O'zgarmas ko'paytuvchini integral belgisidan tashqariga chiqarish mumkin: agar  $k = \text{const}$  bo'lsa, u holda

$$\int kf(x)dx = k \int f(x)dx.$$

4-misol.  $\int (3x^5 + 2x^3 - 3x + 1)dx$  integralni toping.

Yechilishi.  $\int (3x^5 + 2x^3 - 3x + 1)dx = 3 \int x^5 dx + 2 \int x^3 dx - 3 \int x dx + \int dx =$   
 $= \frac{x^6}{2} + \frac{x^4}{2} - \frac{3}{2}x^2 + x + C.$

Javob:  $\frac{x^6}{2} + \frac{x^4}{2} - \frac{3}{2}x^2 + x + C.$

**1.3. Boshlang'ich funksiyalar jadvali.** Ba'zi funksiyalar uchun boshlang'ich funksiyalar jadvalini hosilalar jadvalidan foydalanib tuzish mumkin. Masalan,  $(a^x)' = a^x \ln a$  ekanligini bilgan holda

$$\left( \frac{a^x}{\ln a} \right)' = a^x \text{ ni hosil qilamiz, bundan } f(x) = a^x \text{ funksiyaning boshlan-}$$

g'ich funksiyasi  $F(x) = \frac{a^x}{\ln a} + C$  ko'rinishda yoziladi.

Boshlang'ich funksiyalar jadvali.

	Funksiya	Boshlang'ich funksiyasi
1.	$x^p, p \neq -1$	$\frac{x^{p+1}}{p+1} + C$
2.	$(kx+b)^p, p \neq -1, k \neq 0$	$\frac{(kx+b)^{p+1}}{k(p+1)} + C$
3.	$\sin x$	$-\cos x + C$
4.	$\sin(kx+b), k \neq 0$	$-\frac{1}{k} \cos(kx+b) + C$
5.	$\cos x$	$\sin x + C$
6.	$\cos(kx+b), k \neq 0$	$\frac{1}{k} \sin(kx+b) + C$
7.	$\frac{1}{x}, x > 0$	$\ln x + C$
8.	$a^x$	$\frac{a^x}{\ln a} + C$
9.	$e^x$	$e^x + C$
10.	$\frac{1}{\cos^2 x}$	$\operatorname{tg} x + C$
11.	$\frac{1}{\sin^2 x}$	$-\operatorname{ctg} x + C$
12.	$\operatorname{tg} x$	$-\ln  \cos x  + C$
13.	$\operatorname{ctg} x$	$\ln  \sin x  + C$
14.	$\ln x, x > 0$	$x \ln x - x + C$

5-misol.  $f(x) = 3e^x - 2 \sin x$  funksiyaning barcha boshlang'ich funksiyalarini toping.

Yechilishi. Integrallash qoidalari va  $e^x$  hamda  $\sin x$  uchun boshlang'ich funksiyalar jadvalidan foydalanib, berilgan funksiyaning boshlang'ich funksiyalarini topamiz:

$$F(x) = 3e^x + 2 \cos x + C.$$

Javob:  $3e^x + 2 \cos x + C$ .

6-misol.  $f(x) = \frac{2}{x-2} + 2 \cos(2x+2)$  funksiyaning boshlang'ich funksiyalarini toping.

Yechilishi. Boshlang'ich funksiyalar jadvalidan foydalanamiz:

$$F(x) = 2 \ln(x-2) + \sin(2x+2), x-2 > 0.$$

$$\text{Javob: } 2 \ln(x-2) + \sin(2x+2), x-2 > 0.$$

7-misol.  $f(x) = \sqrt[3]{\frac{x}{3}} - 6 \cos(6x-1)$  funksiyaning boshlang'ich funksiyalarini toping.

Yechilishi. Integrallash qoidalari hamda boshlang'ich funksiyalar jadvalidan foydalanamiz:

$$F(x) = \frac{1}{\sqrt[3]{3}} \cdot \frac{x^{\frac{1}{3}+1}}{\frac{1}{3}+1} - 6 \cdot \frac{1}{6} \sin(6x-1) + C = \frac{x\sqrt[3]{9x}}{4} - \sin(6x-1) + C.$$

$$\text{Javob: } \frac{x\sqrt[3]{9x}}{4} - \sin(6x-1) + C.$$

1-masala.  $f(x) = 6^x + \frac{1}{2x}$  ( $x > 0$ ) funksiyaning grafigi  $M(1;6)$  nuqtadan o'tadigan boshlang'ich funksiyasini toping.

Yechilishi. Berilgan funksiyaning barcha boshlang'ich funksiyalarini boshlang'ich funksiyalar jadvalidan foydalanib topamiz:

$$F(x) = \frac{6^x}{\ln 6} + \frac{1}{2} \ln x + C.$$

Endi shunday  $C$  sonni topamizki, boshlang'ich funksiya  $M(1;6)$  nuqtadan o'tsin:

$$6 = \frac{6}{\ln 6} + \frac{1}{2} \ln 1 + C \Rightarrow \left[ C = 6 - \frac{6}{\ln 6} \right].$$

Shunday qilib,

$$F(x) = \frac{6^x}{\ln 6} + \frac{1}{2} \ln x + 6 - \frac{6}{\ln 6}.$$

$$\text{Javob: } \frac{6^x}{\ln 6} + \frac{1}{2} \ln x + 6 - \frac{6}{\ln 6}.$$

8-misol.  $f(x) = \sin^2 2x$  funksiyaning boshlang'ich funksiyalarini toping.

Yechilishi. Berilgan funksiyaning boshlang'ich funksiyalarini topish uchun

$$\sin^2 2x = \frac{1 - \cos 4x}{2}$$

tenglikdan foydalanamiz. U holda

$$F(x) = \frac{1}{2} x - \frac{1}{8} \sin 4x + C.$$

$$\text{Javob: } \frac{1}{2} x - \frac{1}{8} \sin 4x + C.$$

2-masala.  $f(x) = \sin 2x \cos 4x$  funksiyaning  $x = \frac{\pi}{6}$  da 0 ga teng qiymatni qabul qiladigan boshlang'ich funksiyasini toping.

Yechilishi. Avval berilgan funksiyani yig'indi shakliga keltiramiz:

$$\sin 2x \cos 4x = \frac{1}{2} (\sin 6x - \sin 2x).$$

Boshlang'ich funksiyalar jadvalidan foydalanib, bu funksiyaning boshlang'ich funksiyalarini topamiz:

$$F(x) = -\frac{1}{12} \cos 6x + \frac{1}{4} \cos 2x + C.$$

Endi masala shartini qanoatlantiruvchi  $C$  ni aniqlaymiz:

$$0 = -\frac{1}{12} \cos 6 \cdot \frac{\pi}{6} + \frac{1}{4} \cos 2 \cdot \frac{\pi}{6} + C \Leftrightarrow 0 = -\frac{1}{12} \cos \pi + \frac{1}{4} \cos \frac{\pi}{3} + C \Rightarrow \\ \Rightarrow C = -\frac{5}{24}.$$

Shunday qilib,  $F(x) = -\frac{1}{12} \cos 6x + \frac{1}{4} \cos 2x - \frac{5}{24}$ .

Javob:  $-\frac{1}{12} \cos 6x + \frac{1}{4} \cos 2x - \frac{5}{24}$ .

## 2-§. Aniqmas integralda o'zgaruvchini almashtirish

Boshlang'ich funksiyalar jadvalidan to'g'ridan-to'g'ri foydalanib integrallash *bevosita integrallash* deyiladi.

Boshlang'ich funksiyalar jadvaliga kirmagan  $f(x)$  funksiyaning barcha boshlang'ich funksiyalarini topish, ya'ni  $\int f(x) dx$  integralni hisoblash kerak bo'lsin. O'zgaruvchi  $x$  ni  $t$  erkli o'zgaruvchining bi-ror differensiallanuvchi funksiyasi orqali ifodalab, integrallashning yangi  $t$  o'zgaruvchisini kiritamiz:  $x = \varphi(t)$ , bunga teskari  $t = g(x)$  funksiya mavjud bo'lsin, u holda

$$dx = \varphi'(t) dt \quad (1)$$

bo'lib,

$$\int f(x) dx = \int f(\varphi(t)) \varphi'(t) dt \quad (2)$$

bo'ladi. Bu tenglikning o'ng qismida integrallashdan so'ng eski  $x$  o'zgaruvchiga qaytiladi.

1-misol.  $\int x \sqrt{x-3} dx$  integralni toping.

Yechilishi.  $\sqrt{x-3} = t$  belgilash kiritamiz, bundan  $x - 3 = t^2$ ,  $x = t^2 + 3$ ,  $dx = 2t dt$ . U holda

$$\int x\sqrt{x-3}dx = \int (t^2 + 3)t \cdot 2t \cdot dt = \\ = 2 \int (t^4 + 3t^2) dt = 2 \frac{t^5}{5} + 3 \cdot \frac{t^3}{3} + C = \frac{2}{5}t^5 + t^3 + C.$$

Eski o'zgaruvchiga qaytamiz:

$$\int x\sqrt{x-3}dx = \frac{2}{5}(\sqrt{x-3})^5 + (\sqrt{x-3})^3 + C = \frac{2(x-3)^{\frac{5}{2}}}{5} + (x-3)^{\frac{3}{2}} + C.$$

Javob:  $\frac{2(x-3)^{\frac{5}{2}}}{5} + (x-3)^{\frac{3}{2}} + C.$

2-misol.  $\int x^2 \sin(x^3) dx$  ni toping.

Yechilishi.  $x^3 = t$  belgilash kiritamiz. U holda  $3x^2 dx = dt$  ekanligini e'tiborga olsak,  $\int x^2 \sin(x^3) dx = \frac{1}{3} \int \sin t dt = -\frac{1}{3} \cos t + C =$

$= -\frac{1}{3} \cos(x^3) + C$  ni hosil qilamiz.

Javob:  $-\frac{1}{3} \cos(x^3) + C.$

3-misol.  $\int \frac{dx}{1+e^x}$  ni toping.

Yechilishi.  $1 + e^x = t$  belgilash kiritamiz, bundan  $e^x = t - 1$ ,  $x = \ln(t-1)$ ,  $dx = \frac{dt}{t-1}$ .

U holda

$$\int \frac{dx}{1+e^x} = \int \frac{dt}{t(t-1)}.$$

$\frac{1}{t(t-1)} = \frac{1}{t-1} - \frac{1}{t}$  tenglikni e'tiborga olib,

$$\int \frac{dt}{t(t-1)} = \int \frac{dt}{t-1} - \int \frac{dt}{t} = \ln|t-1| - \ln|t| + C$$

ni hosil qilamiz. Eski o'zgaruvchiga qaytamiz:

$$\int \frac{dx}{1+e^x} = \ln e^x - \ln(1+e^x) + C = x - \ln(1+e^x) + C.$$

Javob:  $x - \ln(1+e^x) + C.$

### 3-§. Bo'laklab integrallash

Integrallashning yana bir usuli, ikki funksiya ko'paytmasini differensiallash qoidasidan kelib chiqadigan

$$\int u dv = uv - \int v du$$

formuladan foydalanishga asoslangan bo'laklab integrallash usuli deb ataluvchi usulni jadvalda keltirilma~~gan~~ funksiyalarning boshlang'ich funksiyalarini topishga tatbiqini ko'rib chiqamiz.

1-misol.  $\int x \cos x dx$  ni toping.

Yechilishi.  $u = x$ ,  $dv = \cos x dx$  desak, 2-§ dagi (1) formulaga ko'ra hamda  $\cos x$  ning boshlang'ich funksiyasi  $\sin x$  ga tengligidan

$$du = dx, v = \sin x$$

larni hosil qilamiz. U holda bo'laklab integrallash formulasiga ko'ra:

$$\int x \cos x dx = x \sin x - \int \sin x dx = x \sin x + \cos x + C.$$

Javob:  $x \sin x + \cos x + C$ .

2-misol.  $\int x^2 \ln x dx$  ni toping.

Yechilishi.  $u = \ln x$ ,  $dv = x^2 dx$  deymiz, bundan

$$du = \frac{1}{x} dx, v = \int x^2 dx = \frac{x^3}{3}.$$

Bo'laklab integrallash formulasiga ko'ra

$$\begin{aligned} \int x^2 \ln x dx &= \frac{1}{3} x^3 \ln x - \frac{1}{3} \int x^3 \cdot \frac{1}{x} dx = \\ &= \frac{1}{3} x^3 \ln x - \frac{1}{3} \int x^2 dx = \frac{1}{3} x^3 \ln x - \frac{1}{3} \cdot \frac{x^3}{3} + C = \frac{x^3 \ln x}{3} - \frac{x^3}{9} + C. \end{aligned}$$

Javob:  $\frac{x^3 \ln x}{3} - \frac{x^3}{9} + C$ .

3-misol.  $\int x e^{-x} dx$  ni toping.

Yechilishi.  $u = x$ ,  $dv = e^{-x} dx$  deymiz, bundan  $du = dx$ ,  $v = -e^{-x}$ .

Bo'laklab integrallash formulasiga ko'ra

$$\int x e^{-x} dx = -x e^{-x} + \int e^{-x} dx = -x \cdot e^{-x} - e^{-x} + C.$$

Javob:  $-x e^{-x} - e^{-x} + C$ .

#### 4-§. Egri chiziqli trapetsiyaning yuzi. Aniq integral

4.1. Egri chiziqli trapetsiyaning yuzini hisoblash. Quyidan  $Ox$  o'qidagi  $[a; b]$  kesma bilan, yuqoridan musbat qiymat qabul qiladigan  $y = f(x)$  uzluksiz funksiyaning grafigi bilan, yon tomonlaridan esa  $x = a$  va  $x = b$  to'g'ri chiziqlarning kesmalari bilan chegaralangan yassi shakl (179-rasm) yuzasini hisoblash masalasini ko'rib

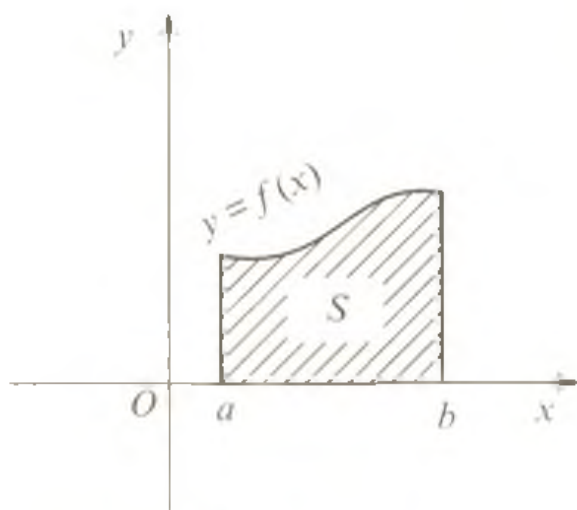

179-rasm

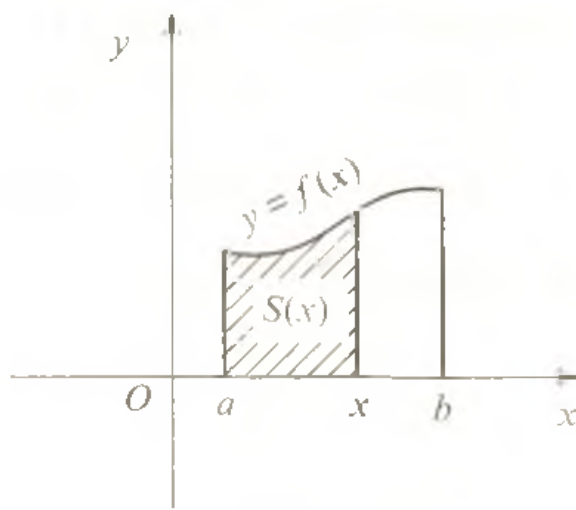

180-rasm

chiqaylik. Bunday shakl *egri chiziqli trapetsiya* deyiladi.  $[a; x]$  asosli egri chiziqli trapetsiyaning yuzini  $S(x)$  deb belgilaymiz (180-rasm), bunda  $x$  – shu  $[a; b]$  kesmaga tegishli ixtiyoriy nuqta.  $x = a$  da  $S(a) = 0$ ;  $x = b$  da  $S(b) = S$ .  $S(x)$  ni  $f(x)$  funksiyaning boshlang'ich funksiyasi, ya'ni  $S'(x) = f(x)$  ekanligini ko'rsatamiz. Buning uchun  $S(x + \Delta x) - S(x)$  ayirmani qaraymiz. Aniqlik uchun  $\Delta x > 0$  holni qaraymiz ( $\Delta x < 0$  hol ham shunga o'xshash qaraladi). Bu ayirma asosi  $[x; x + \Delta x]$  kesmadan iborat bo'lgan trapetsiya yuziga teng (181-rasm).

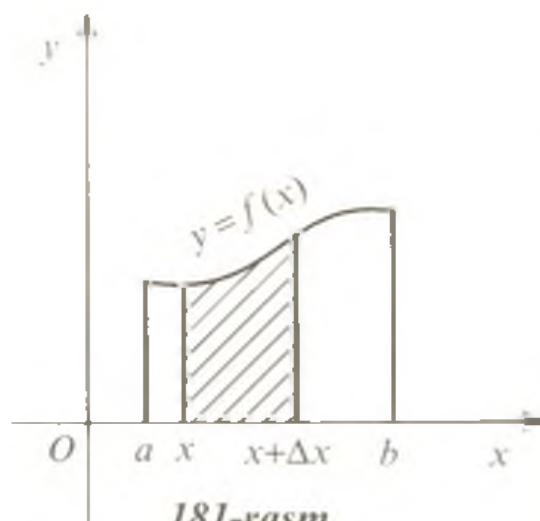

181-rasm

Agar  $\Delta x$  son kichik bo'lsa, u holda bu yuz taqriban  $f(x) \cdot \Delta x$  ga teng bo'ladi, ya'ni  $S(x + \Delta x) - S(x) = f(x)\Delta x$ . Bundan

$$\frac{S(x+\Delta x) - S(x)}{\Delta x} = f(x).$$

$\Delta x \rightarrow 0$  da bu taqribiy tenglikning chap qismi hosila ta'rifi-ga ko'ra  $S'(x)$  ga intiladi va

yaqinlashish xatoligi  $\Delta x \rightarrow 0$  da istalgancha kichik bo'lib boradi. Demak,

$$S'(x) = f(x).$$

Shunday qilib,  $S(x)$  funksiya  $f(x)$  ning boshlang'ich funksiyasi ekan. Istalgan boshqa  $F(x)$  boshlang'ich funksiya  $S(x)$  dan o'zgarmas songa farq qiladi, ya'ni

$$F(x) = S(x) + C. \quad (1)$$

Bu tenglikdan  $x = a$  da  $F(a) = S(a) + C$  ga ega bo'lamiz.  $S(a) = 0$  bo'lgani uchun  $F(a) = C$  U holda (1) tenglikni

$$S(x) = F(x) - F(a)$$

ko'rinishda yozish mumkin. Bundan  $x = b$  da

$$S(b) = F(b) - F(a)$$

ekanini topamiz. Demak, 179- rasmda tasvirlangan egri chiziqli trapetsiya yuzi

$$S = F(b) - F(a) \quad (2)$$

formula bilan topiladi, bunda  $F(x)$  berilgan  $f(x)$  funksiyaning istalgan boshlang'ich funksiyasi.

#### 4.2. Aniq integral

**Ta'rif.**  $f(x)$  funksiya uchun boshlang'ich funksiyaning  $b$  va  $a$  nuqtalaridagi qiymatlarining  $F(b) - F(a)$  ayirmasi shu funksiyaning  $a$  dan  $b$  gacha aniq integrali deyiladi.

Aniq integral

$$\int_a^b f(x) dx$$

kabi belgilanadi. Bunda  $a$  va  $b$  sonlar *integrallash chegaralari* deyiladi ( $b$  – yuqori chegara,  $a$  – quyi chegara),  $\int$  – belgi integral belgisi,  $f(x)$  – integral ostidagi funksiya,  $f(x)dx$  – integral ostidagi ifoda. Shunday qilib, ta'rifga ko'ra,

$$\int_a^b f(x) dx = F(b) - F(a). \quad (3)$$

Bu formula **Nyuton–Leybnis formulasi** deb ataladi.

(2) va (3) formulalardan egri chiziqli trapetsiya yuzini hisoblash formulasi

$$S = \int_a^b f(x) dx \quad (4)$$

ni hosil qilamiz.



**4.3. Aniq integralning xossalari.** Aniq integralning bevosita uning ta'rifidan kelib chiqadigan ayrim xossalarini keltiramiz, bunda  $f(x)$  funksiya qaralayotgan  $[a; b]$  kesmada boshlang'ich funksiyaga ega deb hisoblanadi.

1. Integrallash chegaralari almashtirilganda aniq integral ishorasi o'zgaradi:

$$\int_a^b f(x)dx = -\int_b^a f(x)dx.$$

2.  $a$  ning har qanday qiymati uchun

$$\int_a^a f(x)dx = 0$$

tenglik o'rinli.

3. Agar  $[a; b]$  kesma bir necha qismga bo'linsa, u holda bu kesma bo'yicha aniq integral har bir qism bo'yicha aniq integrallar yig'indisiga teng. Xususan,  $a < c < b$  bo'lsa, u holda

$$\int_a^b f(x)dx = \int_a^c f(x)dx + \int_c^b f(x)dx.$$

4. O'zgarmas ko'paytuvchini aniq integral belgisidan tashqariga chiqarish mumkin: agar  $k = \text{const}$  bo'lsa, u holda

$$\int_a^b k f(x)dx = k \int_a^b f(x)dx.$$

5. Bir nechta funksiyalar algebraik yig'indisining aniq integrali qo'shiluvchilar aniq integrallarining yig'indisiga teng:

$$\begin{aligned} & \int_a^b (f_1(x) \pm f_2(x) \pm \dots \pm f_k(x))dx = \\ & = \int_a^b f_1(x)dx \pm \int_a^b f_2(x)dx \pm \dots \pm \int_a^b f_k(x)dx. \end{aligned}$$

1-misol.  $\int_0^4 (x - 4\sqrt{x})$  ni hisoblang.

Yechilishi. Berilgan aniq integralni boshlang'ich funksiyalar jadvali va aniq integralning hossalariidan hamda Nyuton-Leybnis formulasidan foydalanib hisoblaymiz.

$$\int_0^4 (x - 4\sqrt{x}) dx = \left( \frac{x^2}{2} - 4 \frac{x^{\frac{3}{2}}}{\frac{3}{2}} \right) \Big|_0^4 = \left( \frac{x^2}{2} - \frac{8}{3} x\sqrt{x} \right) \Big|_0^4 =$$

$$= 8 - \frac{8}{3} \cdot 4 \cdot 2 - 0 = 8 - \frac{64}{3} = -13\frac{1}{3}.$$

Javob:  $-13\frac{1}{3}$ .

2-misol.  $\int_0^5 \frac{6}{\sqrt{3x+1}} dx$  ni hisoblang.

Yechilishi.  $\int_0^5 \frac{6}{\sqrt{3x+1}} dx = 6 \int_0^5 (3x+1)^{-\frac{1}{2}} dx = 6 \cdot \frac{1}{3} \cdot 2\sqrt{3x+1} \Big|_0^5 =$

$$= 4(\sqrt{3 \cdot 5 + 1} - \sqrt{3 \cdot 0 + 1}) = 4(4 - 1) = 12.$$

Javob: 12.

3-misol.  $\int_0^{\frac{\pi}{4}} (\cos^2 x - \sin^2 x) dx$  ni hisoblang.

Yechilishi.  $\int_0^{\frac{\pi}{4}} (\cos^2 x - \sin^2 x) dx = \int_0^{\frac{\pi}{4}} \cos 2x dx = \frac{1}{2} \sin 2x \Big|_0^{\frac{\pi}{4}} =$

$$= \frac{1}{2} (\sin 2 \cdot \frac{\pi}{4} - \sin 2 \cdot 0) = \frac{1}{2} (1 - 0) = \frac{1}{2}.$$

Javob:  $\frac{1}{2}$ .

4-misol.  $\int_{\frac{\pi}{2}}^{\frac{3\pi}{4}} \frac{dx}{\sin^2 x}$  ni hisoblang.

Yechilishi.

$$\int_{\frac{\pi}{2}}^{\frac{3\pi}{4}} \frac{dx}{\sin^2 x} = -\operatorname{ctg} x \Big|_{\frac{\pi}{2}}^{\frac{3\pi}{4}} = -(\operatorname{ctg} \frac{3\pi}{4} - \operatorname{ctg} \frac{\pi}{2}) = -(-1 - 0) = 1.$$

Javob: 1.

5-misol.  $\int_1^2 \left( \frac{1}{2x} + e^{2x} \right) dx$  ni hisoblang.

Yechilishi.

$$\int_1^2 \left( \frac{1}{2x} + e^{2x} \right) dx = \frac{1}{2} \int_1^2 \frac{dx}{x} + \int_1^2 e^{2x} dx = \left( \frac{1}{2} \ln x + \frac{1}{2} e^{2x} \right) \Big|_1^2 =$$

$$= \frac{1}{2} (\ln 2 + e^{2 \cdot 2} - \ln 1 - e^{2 \cdot 1}) = \frac{1}{2} (\ln 2 - e^4 - e^2).$$

Javob:  $\frac{1}{2} (\ln 2 - e^4 - e^2)$ .

6-misol.  $\int_{-3}^2 |x^2 + 2x - 3| dx$  ni hisoblang.

Yechilishi.  $[-3; 1]$  oraliqda  $x^2 + 2x - 3 \leq 0$  bo'lganligi uchun modulning ta'rifini hamda aniq integralning xossalari asoslanib integrallashni bajaramiz:

$$\int_3^2 |x^2 + 2x - 3| dx = - \int_3^1 (x^2 + 2x - 3) dx + \int_1^2 (x^2 + 2x - 3) dx = -$$

$$- \left( \frac{x^3}{3} + x^2 - 3x \right) \Big|_{-3}^1 + \left( \frac{x^3}{3} + x^2 - 3x \right) \Big|_1^2 =$$

$$= - \left( \frac{1}{3} + 1 - 3 - (-9 + 9 + 9) \right) + \left( 3 \frac{1}{8} + 6 - 6 \left( \frac{1}{3} + 1 - 3 \right) \right) = 10 \frac{2}{3} + 2 \frac{1}{3} = 13.$$

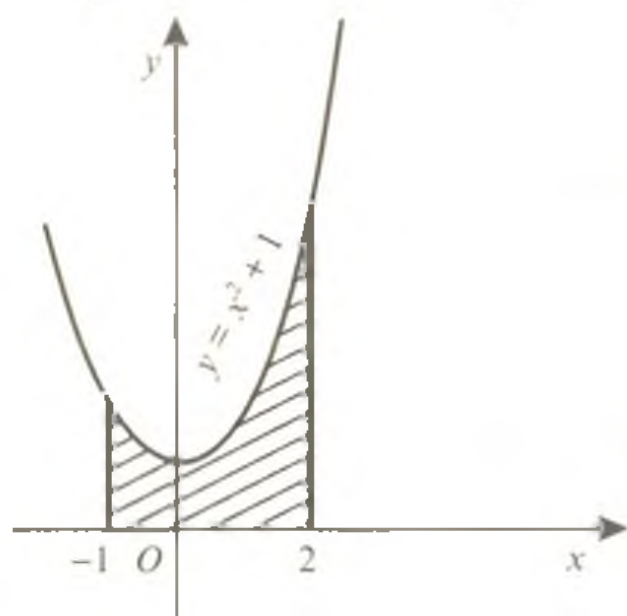

182-rasm

Javob: 13.

Masala.  $y = x^2 + 1$  parabola hamda  $y = -1$  va  $y = 2$  to'g'ri chiziqlar bilan chegaralangan egri chiziqli trapetsiya yuzini hisoblang (182-rasm).

Yechilishi. (4) formulaga ko'ra

$$S = \int_{-1}^2 (x^2 + 1) dx = \left( \frac{x^3}{3} + x \right) \Big|_{-1}^2 = \frac{8}{3} + 2 - \frac{1}{3} - 1 = 3\frac{1}{3} \text{ kv. birlik.}$$

Javob:  $3\frac{1}{3}$  kv. birlik.

### 5-§. Aniq integrallarni yuzlarni hisoblashga tatbiqi

Oldingi paragrafda qaralgan masalada egri chiziqli trapetsiya yuzini aniq integral yordamida qanday hisoblanishini ko'rib chiqdik. Umuman, agar yassi shakl  $x = a$ ,  $x = b$  ( $a < b$ ) to'g'ri chiziqlar va  $y = f_1(x)$ ,  $y = f_2(x)$  egri chiziqlar bilan chegaralangan bo'lsa, (183-rasm) (bunda  $f_1(x) \leq f_2(x)$ ,  $a \leq x \leq b$ ), u holda uning yuzi

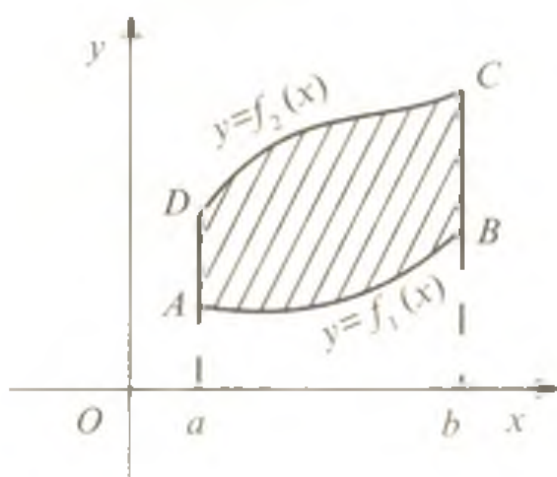

183-rasm

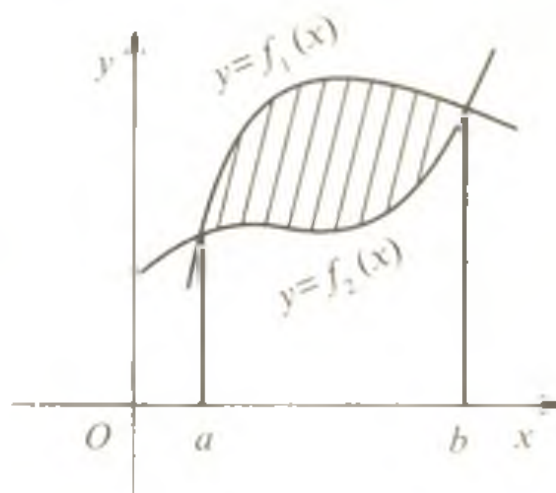

184-rasm

$$S = \int_a^b (f_2(x) - f_1(x)) dx. \quad (1)$$

formula bilan hisoblanadi. Ayrim hollarda (1) formula aniq integralning quyi chegarasi  $a$  yoki yuqori chegarasi  $b$  shu  $y = f_1(x)$  va  $y = f_2(x)$  egri chiziqlarning kesishishi nuqtalarining absissalariga teng bo'lishi mumkin (184-rasm).

1-masala.  $y = x^2 + 2$  parabola va  $y = x + 4$  to'g'ri chiziq bilan chegaralangan shakl yuzini toping.

Yechilish.  $y = x^2 + 2$  va  $y = x + 4$  funksiyalarning grafiklarini yasaymiz va  $x^2 + 2 = x + 4$  tenglamadan bu grafiklar kesishadigan nuqtalarning absissalarini topamiz:

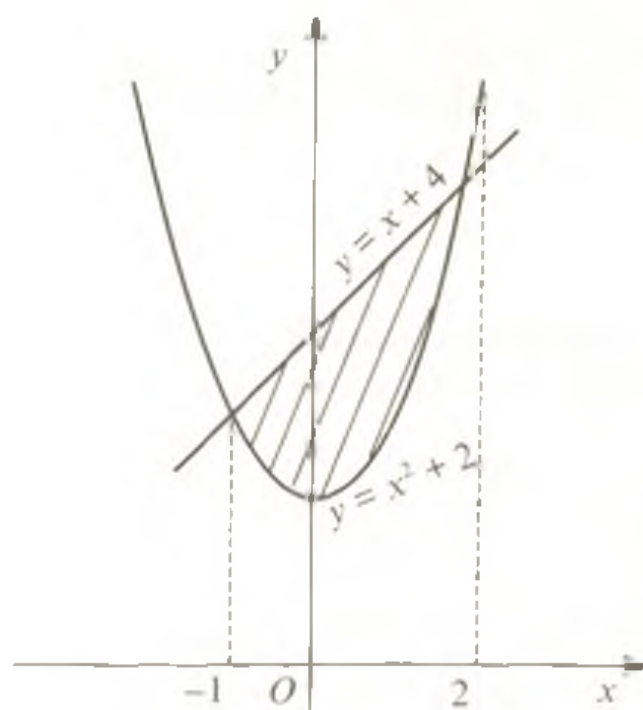

185-rasm

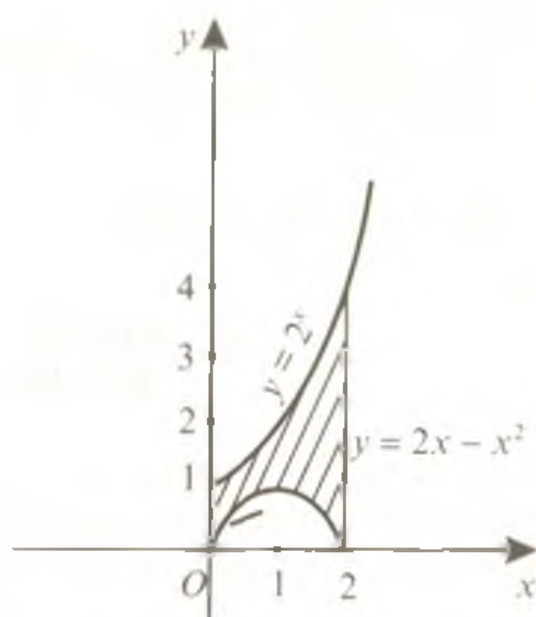

186-rasm

$$x^2 + 2 = x + 4 \Leftrightarrow x^2 - x - 2 = 0 \Rightarrow x_1 = 2, x_2 = -1.$$

Berilgan funksiyalar grafiklari bilan chegaralangan shakl 185-rasmda tasvirlangan. Shakl yuzini (1) formula bo'yicha hisoblaymiz:

$$S = \int_{-1}^2 (x + 4 - x^2 - 2) dx = \int_{-1}^2 (-x^2 + x + 2) dx = \left( -\frac{x^3}{3} + \frac{x^2}{2} + 2x \right) \Big|_{-1}^2 =$$

$$= -\frac{8}{3} + \frac{4}{2} + 4 - \frac{1}{3} - \frac{1}{2} + 2 = 4\frac{1}{2} \text{ kv. birlik.}$$

Javob:  $4\frac{1}{2}$  kv. birlik.

2-masala.  $y = 2^x$ ,  $y = 2x - x^2$  egri chiziqlar va  $x = 0$ ,  $x = 2$  to'g'ri chiziqlar bilan chegaralangan shakl yuzini hisoblang.

Yechilishi.  $[0; 2]$  kesmada  $y = 2^x$  va  $y = 2x - x^2$  funksiyalarning grafiklarini yasaymiz (186-rasm). Rasmda tasvirlangan shakl yuzini (1) formula bilan topamiz:

$$S = \int_0^2 (2^x - (2x - x^2)) dx = \left( \frac{2^x}{\ln 2} - x^2 + \frac{x^3}{3} \right) \Big|_0^2 = \left( \frac{3}{\ln 2} - \frac{4}{3} \right) \text{ kv. birlik.}$$

lik.

Javob:  $\left( \frac{3}{\ln 2} - \frac{4}{3} \right)$  kv. birlik.

### 6-§. Aylanish jismlarining hajmini hisoblash

Agar qaralayotgan jism  $y = f(x)$  egri chiziq bilan chegaralangan egri chizikli trapetsiyaning  $Ox$  o'q atrofida aylanishidan hosil bo'lsa, u holda  $Ox$  o'qiga perpendikular  $x$  absissali kesim doiradan iborat bo'lib, uning radiusi  $y = f(x)$  ordinataga mos keladi (187-rasm) va  $S(x) = \pi y^2$  bo'lib,  $Ox$  o'qi atrofida aylanayotgan jism hajmi

$$V = \pi \int_a^b y^2 dx \quad (1)$$

formula bilan topiladi.

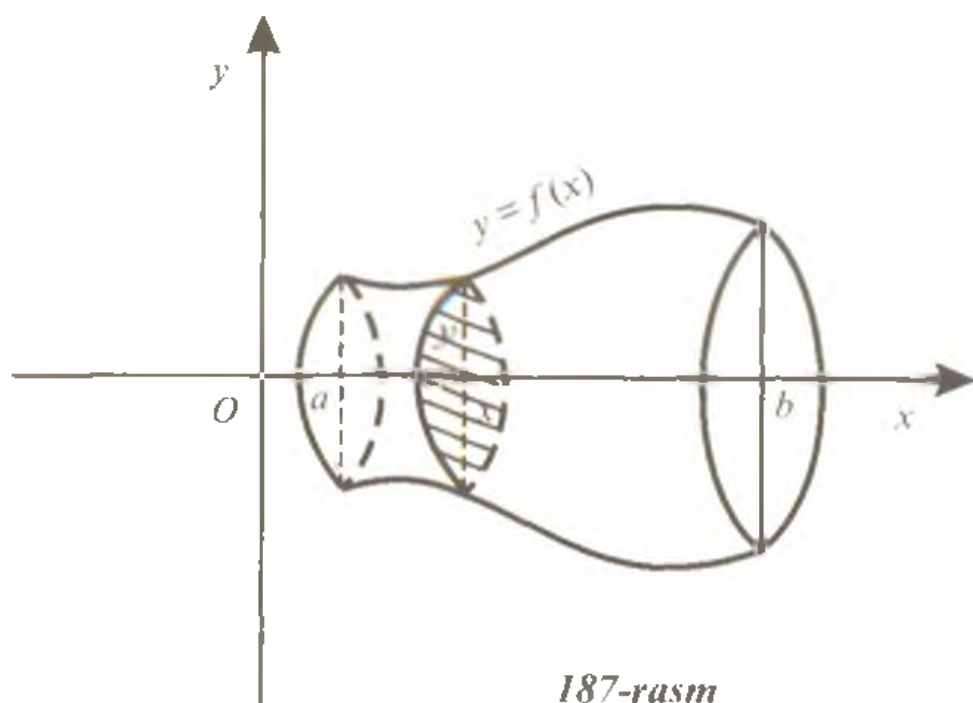

187-rasm

1-masala. Radiusi  $R$  ga teng shar hajmini toping.

Yechilishi. Shar tenglamasi  $y = \sqrt{R^2 - x^2}$  dan iborat yarim aylanani absissa o'qi atrofida aylanishi natijasida hosil bo'ladi.

bunda  $-R \leq x \leq R$ . Uning hajmini (1) formuladan foydalanib topamiz:

$$V = \pi \int_{-R}^R (R^2 - x^2) dx = \pi \left( R^2 x - \frac{x^3}{3} \right) \Big|_{-R}^R = \frac{4}{3} \pi R^3 \text{ kub birlik.}$$

Javob:  $\frac{4}{3} \pi R^3$  kub birlik.

2-masala. Absissa o'qi atrofida  $y = \frac{4}{x}$  giperbola va  $y = 3, x = 6$  to'g'ri chiziqlar bilan chegaralangan egri chizikli trapeziyaning aylanishi natijasida hosil bo'lgan jism hajmini toping.

Yechilishi. (1) formulaga ko'ra

$$V = \pi \int_3^6 \left( \frac{4}{x} \right)^2 dx = 16\pi \int_3^6 \frac{dx}{x^2} = -16\pi \cdot \frac{1}{x} \Big|_3^6 = -16\pi \left( \frac{1}{6} - \frac{1}{3} \right) =$$

$$= -16\pi \cdot \left( -\frac{1}{6} \right) = 2 \frac{2}{3} \pi$$

Javob:  $2 \frac{2}{3}$  kub birlik.

## 7-§. Eng sodda differensial tenglamalar

**7.1. Differensial tenglamaga keltiriladigan ayrim masalalar.** Tabiatshunoslik va texnikaning ko'pgina masalalari qaralayotgan hodisa yoki jarayonni tavsiflaydigan noma'lum funktsiyani topishga keltiriladi.

1-masala. Massasi  $m$  bo'lgan moddiy nuqta og'irlik kuchi ta'sirida erkin tushmoqda. Havoning qarshiligini hisobga olmay, bu moddiy nuqtaning harakat qonunini toping.

Yechilishi. Moddiy nuqtaning vaziyati  $s$  koordinata bilan aniqlanib,  $u$   $t$  vaqtga bog'liq ravishda o'zgaradi. Boshlang'ich  $t = 0$  momentda moddiy nuqtaning tezligi  $v_0$  ga, uning sanoq boshi  $0$  dan uzoqligi esa  $s_0$  ga teng bo'lsin (188-rasm). Nyutonning ikkinchi qonuniga ko'ra



188-rasm

$$ma = F, \quad (1)$$

bunda  $m$  – moddiy nuqtaning massasi,  $a$  – moddiy nuqtaning tezlanishi,  $F$  – ta'sir etuvchi kuch. Masala shartiga ko'ra moddiy nuqtaga faqat og'irlik kuchi ta'sir etadi. Demak,  $F = mg$  ( $g$  erkin tushish tezlanishi). Shunga ko'ra, (1) tenglikni quyidagicha yozamiz:

$$ms''(t) = mg \text{ yoki } s''(t) = g. \quad (2)$$

(2) tenglik noma'lum funksiya  $s = s(t)$  ning ikkinchi tartibli hosilasini o'z ichiga olgan tenglamadan iboratdir. Bu tenglamadan izlanayotgan  $s(t)$  funksiyani ikki marta integrallash yo'li bilan topish mumkin:

$$s'(t) = gt + C_1. \quad (3)$$

$$s(t) = \frac{gt^2}{2} + C_1t + C_2. \quad (4)$$

(4) tenglik izlanayotgan harakat qonunini ifodalaydi, unda ikkita integrallash doimiylari  $C_1$  va  $C_2$  qatnashadi. Ularni nuqtaning boshlang'ich holati va boshlang'ich tezligini hisobga olib aniqlash mumkin.  $s'(t)$  tezlikni ifodalagani uchun (3) dan  $t = 0$  deb  $C_1 = v_0$ , (4) dan esa  $C_2 = s_0$  ni topamiz. Shunday qilib, (4) harakat qonunining xususiy ko'rinishi quyidagicha bo'ladi:

$$s(t) = \frac{gt^2}{2} + v_0t + s_0.$$

Javob:  $s(t) = \frac{gt^2}{2} + v_0t + s_0.$

2-masala. Balandligi 2 m ga, asosining radiusi 0,5 m ga teng bo'lgan silindrik bak suv bilan to'ldirilgan. Bak tubidagi doiraviy jo'mrakning radiusi 0,1 m ga teng bo'lsa, bak ichidagi suv qancha vaqt ichida oqib chiqib ketadi?

Yechilishi. Bakning balandligini  $h$ , uning asosi radiusini  $R$ , jo'mrakning radiusini  $r$  deb belgilaymiz (189-rasm), vaqt sekundlarda o'lchanadi.

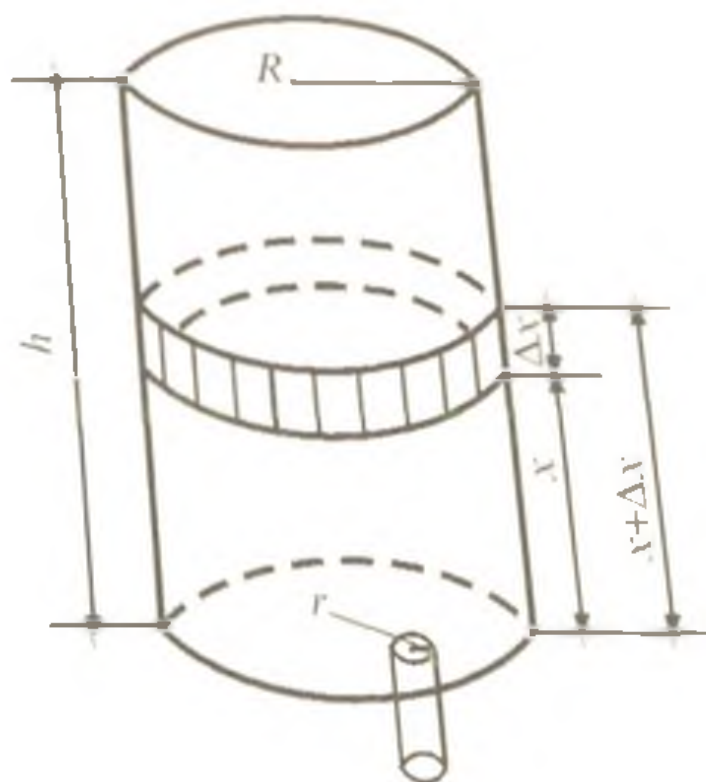

189-rasm



Suyuqlikning oqib chiqish tezligi  $v$  bak asosidan suyuqlik sathigacha bo'lgan masofa  $x$  ga bog'liq bo'lib, ushbu Bernulli formulasi

$$v = k\sqrt{2gx}$$

bilan hisoblanadi, bunda  $g \approx 9,8 \text{ m/s}^2$  – erkin tushish tezlanishi,  $k$  – suyuqlikning xossasiga bog'liq bo'lgan koeffitsiyent (suv uchun  $k = 0,6$ ). Bu formuladan ko'rinib turibdiki, suv kamaygan sari uning oqib chiqish tezligi ham kamayadi. Suvning oqib chiqib ketishiga ketadigan vaqt  $t(x)$  bo'lsin.  $t_1 = t(x + \Delta x) - t(x)$  vaqt ichida suvning oqib chiqish tezligi Bernulli formulasi bilan ifodalanadi deb

$$\frac{t(x+\Delta x) - t(x)}{\Delta x}$$

nisbatni qaraymiz.

$t_1$  vaqt ichida bakdan oqib chiqqan suvning hajmi balandligi  $\Delta x$  ga teng bo'lgan silindr hajmi  $\pi R^2 \Delta x$  ga teng, ikkinchi tomondan bu hajm jo'mrakning ko'ndalang kesim yuzi  $\pi r^2$  ni  $v \cdot t_1$  ga ko'paytirilganiga teng, ya'ni

$$\pi R^2 \Delta x = \pi r^2 v t_1. \text{ Bundan } \frac{t(x+\Delta x) - t(x)}{\Delta x} = \frac{R^2}{r^2 k \sqrt{2gx}}.$$

Bu taqribiy tenglikda yaqinlashish xatoligi  $\Delta x \rightarrow 0$  da nolga intiladi. Demak,  $\Delta x \rightarrow 0$  da

$$t'(x) = \frac{R^2}{r^2 k \sqrt{2gx}} \quad (5)$$

differensial tenglamaga ega bo'lamiz. Uning yechimlar to'plami

$$t(x) = \frac{R^2 \sqrt{2x}}{r^2 k \sqrt{g}} + C \quad (6)$$

shaklida yoziladi.

Agar  $x = 0$  (bakda suv yo'q) bo'lsa,  $t(0) = 0$ , bundan  $C = 0$ .  $x = h$  uchun izlanayotgan vaqtni topamiz:

$$t(h) = \frac{R^2 \sqrt{2h}}{r^2 k \sqrt{g}}.$$

Masala shartlariga ko'ra  $h = 2$  m,  $R = 0,5$ ,  $r = 0,1$  m hamda  $g = 9,8 \frac{\text{m}}{\text{s}^2}$ ,  $k = 0,6$  ekanligini hisobga olsak,

$$t(2) = \frac{0,25 \cdot \sqrt{2 \cdot 2}}{0,01 \cdot 0,6 \sqrt{9,8}} \approx 27 \text{ s.}$$

Javob: 27 s.

## 7.2. Oddiy differensial tenglamalarga oid asosiy tushunchalar.

Yuqoridagi masalalarni yechishda qaralgan (2) va (5) tenglamalar noma'lum funksiyalarning (birinchi masalada  $s(t)$ , ikkinchi masalada  $t(x)$ ) ikkinchi va birinchi tartibli hosilalarini o'z ichiga olgan. Bunday erkli o'zgaruvchi va noma'lum funksiya hamda uning hosilalarini bog'lovchi tenglama *differensial tenglama* deb ataladi.

Agar noma'lum funksiya faqat bitta erkli o'zgaruvchiga bog'liq bo'lsa, bunday differensial tenglama *oddiy differensial tenglama* deyiladi. Differensial tenglamaga kirgan hosilaning eng yuqori tartibi *tenglamaning tartibi* deyiladi.

Masalan,  $y' \sin x + y \cos x = 1$  tenglama – birinchi tartibli tenglama;  $y'' = \sin x$  – ikkinchi tartibli tenglama;  $y''' = xy$  – uchinchi tartibli tenglama va hokazo.

*Differensial tenglamaning yechimi yoki integrali* deb tenglamaga qo'yganda uni ayniyatga aylantiradigan har qanday differensiallanuvchi  $y = f(x)$  funksiyaga aytiladi. Bu funksiyaning  $Oxy$  tekislikdagi grafigi *integral egri chiziq* deb atalib, tenglamani yechish jarayoni esa differensial tenglamani *integrallash* deyiladi.

1-misol. Ushbu  $y = 3e^x$  va  $y = 4e^{-x}$  funksiyalar  $y'' - y = 0$  differensial tenglamaning yechimi bo'lishini ko'rsating.

Yechilishi. 1)  $y = 3e^x$  funksiyaning berilgan differensial tenglamaning yechimi ekanini ko'rsatamiz.  $y'$  va  $y''$  larni topamiz:

$$y' = 3e^x; y'' = 3e^x$$

Bularni berilgan tenglamaga qo'yamiz:

$$3e^x - 3e^x = 0, 0 = 0$$

Demak,  $y = 3e^x$  funksiya  $y'' - y = 0$  tenglamaning yechimi ekan.

2) Xuddi shu jarayonni ikkinchi funksiya uchun ham bajaramiz:

$$y = 4e^{-x}, y' = -4e^{-x}, y'' = 4e^{-x}.$$

$$4e^{-x} - 4e^{-x} = 0, 0 = 0$$

Demak,  $y = 4e^{-x}$  funksiya ham  $y'' - y = 0$  tenglamaning yechimi ekan.

2-misol.  $y' = x + 2$  differensial tenglamani yeching.

Yechilishi. Hosilasi  $x + 2$  ga teng  $y(x)$  funksiyani, ya'ni  $x + 2$  funksiyaning boshlang'ich funksiyasini topamiz. Boshlang'ich funksiyalarni topish qoidalaridan quyidagini hosil qilamiz:

$$y = \frac{x^2}{2} + 2x + C,$$

bu yerda  $C$  – integrallash doimiysi

Javob:  $\frac{x^2}{2} + 2x + C.$

**Differensial tenglamaning yechimi o'zgarmasgacha aniqlikda bir qiymatlimas aniqlanadi.** Odatda differensial tenglamaga integrallash doimiysi aniqlanadigan shartlar qo'shiladi. Bunday shartlar *boshlang'ich shart* deyiladi.

3-misol.  $y' = \cos x$  differensial tenglamaning  $y(0) = 2$  shartni qanoatlantiruvchi yechimini toping.

Yechilishi. Bu tenglamaning barcha yechimlari  $y = \sin x + C$  ko'rinishda yoziladi.  $y(0) = 2$  shartdan

$$\sin 0 + C = 2$$

ga ega bo'lamiz. bundan  $C = 2$  ni topamiz.

Javob:  $y = \sin x + 2.$

Differensial tenglamaning *umumiy yechimi* deb bu tenglamani qanoatlantiradigan  $y = f(x, C)$  funksiyaga aytiladi, bunda  $C$  – ixtiyoriy o'zgarmas son. Differensial tenglamaning umumiy yechimidan ixtiyoriy o'zgarmasning boshlang'ich shartlarini qanoatlantiruvchi qiymatlarida hosil qilinadigan yechimlar *xususiy yechimlar* deyiladi.

**7.3. O'zgaruvchilari ajraladigan differensial tenglamalar.** Differensial tenglamaning eng sodda turi *o'zgaruvchilari ajralgan tenglamadir*:

$$M(x)dx + N(y)dy = 0. \quad (7)$$

Bu tenglamaning umumiy integrali uni hadlab integrallash orqali hosil qilinadi:

$$\int M(x)dx + \int N(y)dy = C. \quad (8)$$

Ixtiyoriy o'zgarmasni berilgan tenglama uchun qulay bo'lgan is-  
talgan ko'rinishda olish mumkin.

4-misol.  $x dx + y dy = 0$  differensial tenglamaning umumiy  
yechimini toping.

Yechilishi. Berilgan tenglamani hadma-had integrallab

$$\frac{x^2}{2} + \frac{y^2}{2} = C$$

tenglikni hosil qilamiz.  $2C = C^2$  deb belgilab

$$x^2 + y^2 = C^2$$

ga ega bo'lamiz. Bu – markazi koordinata boshida, radiusi  $C$  larga  
teng bo'lgan konsentrik aylanalar tenglamasidir.

Javob:  $x^2 + y^2 = C^2$ .

Ushbu

$$M_1(x)N_1(y)dx + M_2(x)N_2(y)dy = 0 \quad (9)$$

ko'rinishdagi differensial tenglama o'zgaruvchilari ajraladigan tenglama  
deyiladi. (9) tenglamani  $N_1(y)M_2(x) \neq 0$  ifodaga bo'lib, uni (7)  
shaklidagi o'zgaruvchilari ajralgan tenglamaga keltirish mumkin:

$$\frac{M_1(x)}{M_2(x)} dx + \frac{N_2(y)}{N_1(y)} dy = 0. \quad (10)$$

Ushbu

$$y' = f_1(x) \cdot f_2(y) \quad (11)$$

ko'rinishdagi tenglama ham o'zgaruvchilari ajraladigan tenglama-

dir. Bunda  $y' = \frac{dy}{dx}$  deb, tenglamaning chap hamda o'ng tomonlari-

ni  $dx$  ga ko'paytirib,  $dy = f_1(x) \cdot f_2(y) \cdot dx$  ko'rinishdagi tenglama  
hosil qilinadi. Bundan

$$\frac{dy}{f_2(y)} = f_1(x) dx. \quad (12)$$

(12) ni integrallab

$$\int \frac{dy}{f_2(y)} = \int f_1(x) dx + C$$

ni hosil qilamiz.

5-misol.  $y' = \frac{e^x}{1+e^x} \cdot \frac{1}{y}$  differensial tenglamaning  $y(0) = \sqrt{2}$  boshlang'ich shartni qanoatlantiruvchi xususiy yechimini toping.

Yechilishi.  $y' = \frac{dy}{dx}$  deb, tenglamaning o'zgaruvchilarini ajratamiz:

$$y \, dy = \frac{e^x}{1+e^x} \, dx.$$

Integrallab, umumiy yechimni hosil qilamiz:

$$\frac{y^2}{2} = \ln(1+e^x) + C,$$

bunda  $2\bar{C} = \ln C$  desak,  $y = \sqrt{2 \ln C \cdot (1+e^x)}$ . Bu umumiy yechimga

$x = 0, y = \sqrt{2}$  ni qo'yib,  $C = \frac{e}{2}$  ekanligini topamiz. Izlanayotgan xususiy yechim

$$y = \sqrt{2 \ln \frac{e}{2} (1+e^x)}$$

ko'rinishda bo'ladi.

Javob:  $y = \sqrt{2 \ln \frac{e}{2} (1+e^x)}$ .

### Mustaqil ishlash uchun test topshiriqlari

1.  $f(x) = 5x^4 + 3x^2$  funksiyaning boshlang'ich funksiyasini toping.

A)  $\frac{x^5}{5} + \frac{x^3}{3} + C$ ; B)  $x^5 + x^3 + C$ ; C)  $\frac{x^4}{20} + \frac{x^3}{6} + C$ ;

D)  $x^4 + x^3 + C$ ; E)  $\frac{x^3}{4} + \frac{x^3}{4} + C$ .

2.  $f(x) = 4\sqrt[3]{x} - 6\sqrt{x}$  funksiyaning boshlang'ich funksiyasini toping.

A)  $12x\sqrt[3]{x} - 12x\sqrt{x} + C$ ; B)  $\frac{16}{3}x\sqrt[3]{x} - 9x + x^3\sqrt{x} + C$ ;

C)  $3x\sqrt[3]{x} - 4x\sqrt{x} + C$ ; D)  $3\sqrt[3]{x^2} - 4\sqrt{x} + C$ ;

E)  $4x\sqrt[3]{x} + 2x\sqrt{x} + C$ .

3.  $f(x) = e^{\frac{x}{5}} + \cos 2x$  funksiyaning boshlang'ich funksiyasini toping.

A)  $5e^{\frac{x}{5}} + \frac{1}{2} \sin 2x + C$ ; B)  $e^{\frac{x}{5}} + \sin 2x + C$ ;

C)  $\frac{1}{5}e^{\frac{x}{5}} + \frac{1}{2} \sin x + C$ ; D)  $5e^{\frac{x}{5}} + \frac{1}{2} \cos 2x$ ; E)  $e^{\frac{x}{5}} + 2 \sin 2x + C$ ;

4.  $f(x) = \frac{1}{x-2} - 2 \sin(2x-1)$  funksiyaning boshlang'ich funksiyasini toping.

A)  $x-2 - 2 \cos(2x-1) + C$ ; B)  $\ln(x-2) + 2 \cos(2x-1) + C$ ;

C)  $x-2 + 2 \cos(2x-1) + C$ ; D)  $\ln(x-2) + \cos(2x-1) + C$ ;

E)  $-2 \ln(x-2) + \cos(2x-1) + C$ .

5.  $f(x) = 7 \cos \frac{x}{7} + 3e^{3x-\frac{1}{2}}$  funksiyaning boshlang'ich funksiyasini toping.

A)  $7 \sin \frac{x}{7} + 3e^{3x-\frac{1}{2}} + C$ ; B)  $49 \sin \frac{x}{7} + e^{3x-\frac{1}{2}} + C$ ;

C)  $-49 \sin \frac{x}{7} + e^{3x-\frac{1}{2}} + C$ ; D)  $-7 \sin \frac{x}{7} + e^{3x-\frac{1}{2}} + C$ ;

E)  $\sin \frac{x}{7} + e^{3x-\frac{1}{2}} + C$ .

6.  $f(x) = \sqrt{x}$  funksiya uchun grafigi  $M(9;10)$  nuqtadan o'tadigan boshlang'ich funksiyasini toping.

A)  $\frac{2}{3}x\sqrt{x} - 8$ ; B)  $\frac{2}{3}x\sqrt{x} + 18$ ; C)  $\frac{2}{3}x\sqrt{x} + 27$ ;

D)  $\frac{3}{2}\sqrt{x} + 8$ ; E)  $\frac{3}{2}x\sqrt{x} - 8$ .

7.  $f(x) = \sin 2x$  funksiya uchun grafigi  $M\left(\frac{\pi}{2}; 5\right)$  nuqta orqali o'tuvchi boshlang'ich funksiyani ko'rsating.

- A)  $-\frac{1}{2}\cos 2x + 4,5$  B)  $\frac{1}{2}\cos 2x + 4,5$ ; C)  $\frac{1}{2}\cos 2x - 4,5$ ;  
 D)  $-\cos 2x + 6$ ; E)  $\cos 2x - 6$ .

8.  $f(x) = \cos^2 x$  funksiyaning boshlang'ich funksiyasini toping.

A)  $\frac{\cos^3 x}{3} + C$ ; B)  $\sin^2 x + C$ ; C)  $\frac{1}{3}\sin^3 x + C$ ;

D)  $\frac{1}{2}x + \frac{1}{4}\sin 2x + C$ ; E)  $\frac{1}{2}x + \frac{1}{2}\sin 2x + C$ ;

9.  $f(x) = \operatorname{tg}^2 x$  funksiyaning boshlang'ich funksiyasini toping.

A)  $\frac{\operatorname{tg}^3 x}{3} + C$ ; B)  $\ln \cos x + C$ ; C)  $\operatorname{tg} - x + C$ ; D)  $\operatorname{ctg}^3 x + C$ ;

E)  $\operatorname{tg}^2 x - x + C$ .

10.  $y = 2 \sin 5x + 2 \cos \frac{x}{2}$  funksiyaning  $x = \frac{\pi}{3}$  da 0 ga teng qiymatni qabul qiladigan boshlang'ich funksiyasini toping.

A)  $4 \sin \frac{x}{2} - \frac{2}{5} \cos 5x - 1,8$ ; B)  $\sin \frac{x}{2} - 10 \cos 5x + 4,5$ ;

C)  $6 \sin \frac{x}{2} - \frac{2}{5} \cos 5x - 2,8$ ; D)  $6 \sin \frac{x}{2} - \frac{2}{5} \cos 5x + 2,8$ ;

E)  $4 \sin \frac{x}{2} - \frac{2}{5} \cos 5x + 1,8$ .

11.  $f(x) = (5^x - 1)(5^{-x} + 1)$  funksiya uchun grafigi koordinata boshidan o'tadigan boshlang'ich funksiyasini toping.

A)  $2 \cdot 5^x \ln 5 - 2 \ln 5$ ; B)  $(5^x - 5^{-x}) \ln 5$ ; C)  $5^{x-1} + 5^{-x-1}$ ;

D)  $2 \cdot 5^x \ln 5 - \frac{2}{\ln 5}$ ; E)  $\frac{5^x + 5^{-x} - 2}{\ln 5}$ .

12.  $f(x) = \frac{32^x - 2^x}{4^x}$  funksiyaning boshlang'ich funksiyasini toping.

A)  $\frac{32^x \ln 32 - 2^x \ln 2}{4^x \ln 4} + C$ ; B)  $\left( \frac{2^{3x}}{3} + 2^{-x} \right) \ln 2 + C$ ;

C)  $\frac{2^{2x} + 3}{2^x \cdot 3 \ln 2} + C$ ; D)  $\frac{2^{4x} - 3}{2^x \cdot 3 \ln 2} + C$ ; E)  $\left( \frac{2^{4x}}{4} + 2^{-x} \right) \ln 2 + C$ .

13.  $f(x) = \frac{\cos 4x - \cos 6x}{\sin 5x}$  funksiyaning boshlang'ich funksiyasini toping.

- A)  $\frac{1}{\cos^2 x} - \frac{1}{\sin^2 x} + C$ ; B)  $-\frac{1}{4} \sin 4x + \frac{1}{6} \cos 6x - \frac{1}{5} \cos 5x + C$ ;  
 C)  $-2 \cos x + C$ ; D)  $-2 \cos 2x + C$ ; E)  $-2 \cos 10x + C$ .

14\*.  $f(x) = \frac{x}{x-2}$  funksiyaning boshlang'ich funksiyasini toping.

- A)  $x + 2 \ln(x-2) + C$ ; B)  $\frac{x^2}{2} - 2 + C$ ; C)  $x - \ln(x-2) + C$ ;  
 D)  $2x \ln(x-2) + C$ ; E)  $\frac{x}{2 \ln x} + C$ ;

15\*.  $\int \frac{x^2 dx}{8+x^3}$  integralni toping.

- A)  $\frac{x^3}{3} + \ln(8+x^3) + C$ ; B)  $\frac{x^3}{3} + \frac{x^4}{4} + 8x + C$ ; C)  $\frac{1}{3} \ln(8+x^3) + C$ ;  
 D)  $\frac{1}{3} (x^2 \cdot \ln(8+x^3)) + C$ ; E)  $x^2 \ln(8+x^3) + C$ .

16\*.  $\int \frac{dx}{x \ln x}$  integralni toping.

- A)  $\ln x + \frac{1}{\ln x} + C$ ; B)  $-\frac{1}{x^2} + \frac{1}{\ln x} + C$ ; C)  $\frac{1}{x^2} + \frac{1}{\ln x} + C$ ;  
 D)  $\frac{\ln x}{x} + C$ ; E)  $\ln(\ln x) + C$ .

17\*.  $\int x \sqrt{x^2 - 7} dx$  integralni toping.

- A)  $\frac{x^2}{2} + \frac{2\sqrt{(x^2-7)^3}}{3} + C$ ; B)  $\frac{\sqrt{(x^2-7)^3}}{3} + C$ ; C)  $\frac{2x^2\sqrt{(x^2-7)^3}}{6} + C$ ;  
 D)  $\frac{x^2}{2} - \frac{2\sqrt{(x^2-7)^3}}{3} + C$ ; E)  $\frac{x^3\sqrt{(x^2-7)^3}}{6} + C$ .

18\*.  $\int \sin x \cos^2 x dx$  integralni toping.

- A)  $-\cos x + \frac{\cos^3 x}{3} + C$ ; B)  $-\cos x + \frac{\sin^3 x}{3} + C$ ; C)  $-\frac{\cos^3 x}{3} + C$ ;  
 D)  $\frac{\sin^3 x}{3} + C$ ; E)  $-\cos x + \frac{\sin^4 x}{3} + C$ .



19.  $\int (x-5)\sin x dx$  integralni toping.

A)  $(5-x)\cos x + \sin x + C$ ; B)  $-\frac{x^2}{2}\cos x - 5\cos x + C$ ;

C)  $-\frac{x^2}{2}\cos x + 5\cos x + C$ ; D)  $-\frac{(x-5)^2}{2}\cos x + C$ ;

E)  $-x\cos x - \frac{5\sin^2 x}{2} + C$ ;

20\*.  $\int x^2 e^{2x} dx$  integralni toping.

A)  $\frac{x^3}{3}e^x$ ; B)  $\frac{x^3 e^{2x}}{6} + C$ ; C)  $\left(\frac{x^3}{3} + 2x^2 - 2x\right)e^{2x} + C$ ;

D)  $\frac{1}{4}e^{2x}(2x^2 - 2x + 1) + C$ ; E)  $\frac{1}{2}e^{2x}(x^2 - x + \frac{1}{4}) + C$ .

21\*.  $\int e^x \cos x dx$  integralni toping.

A)  $\frac{e^x}{2}(\sin x + \cos x) + C$ ; B)  $e^x \sin x + C$ ; C)  $e^x + \sin x + C$ ;

D)  $\frac{e^x}{2}(\cos x - \sin x) + C$ ; E)  $\frac{e^x}{2}(\sin x - \cos x) + C$ .

22\*.  $\int x \ln(2x) dx$  integralni toping.

A)  $1 + \frac{x^2}{2} \ln(2x) + 2x + C$ ; B)  $\frac{x^2}{2} \ln(2x) - \frac{x}{2} + C$ ;

C)  $\frac{x^2}{2} + \ln(2x) + 2x + C$ ; D)  $\frac{x^2}{2} \ln(2x) + \frac{x^2}{4} + C$ ;

E)  $\frac{x^2}{2} \ln(2x) - \frac{x^2}{4} + C$ .

23.  $\int_1^2 6x^5 dx$  ni toping.

A) 63; B) 31; C) 4800; D) 1; E) 65.

24.  $\int_0^3 (3x - e^{\frac{x}{3}}) dx$  ni toping.

A)  $16,5 - 3e$ ; B)  $10,5 - 3e$ ; C)  $13,5 - 3e$ ; D)  $16,5 - \frac{e}{3}$ ; E)  $13,5 - \frac{e}{3}$ .

25.  $\int_0^{\frac{\pi}{3}} \frac{\sin 2x}{\cos x} dx$  ni toping.

A)  $\frac{1}{4}$ ; B)  $-1$ ; C)  $1$ ; D)  $-3$ ; E)  $-\frac{1}{2}$ .

26.  $\int_{\sqrt{e}}^e x \ln x dx$  ni toping.

A)  $\frac{e^2 - e}{2} - \frac{3}{4}$ ; B)  $\frac{e^2}{4}$ ; C)  $\frac{e^2}{2} - \frac{e}{4}$ ; D)  $e^2 - \frac{e}{4}$ ; E)  $2e^2$ .

27.  $\int_0^{\frac{\pi}{4}} \sin^2\left(\frac{\pi}{4} - x\right) dx$  ni toping.

A)  $\frac{\pi}{2} + \frac{1}{4}$ ; B)  $\frac{\pi}{2} - \frac{1}{4}$ ; C)  $\frac{\pi}{4} - \frac{1}{4}$ ; D)  $\frac{\pi}{8} + \frac{1}{4}$ ; E)  $\frac{\pi}{8} - \frac{1}{4}$ .

28.  $\int_0^{0,5} e^{\sin \pi x} \cos \pi x dx$  ni toping.

A)  $e - 1$ ; B)  $\sqrt{e} - 1$ ; C)  $\frac{\sqrt{e-1}}{\pi}$ ; D)  $\frac{e-1}{\pi}$ ; E)  $\frac{e}{\pi}$ .

29.  $\int_0^{e^2-1} \frac{dx}{x+1}$  ni toping.

A)  $3$ ; B)  $-3$ ; C)  $2$ ; D)  $-2$ ; E)  $e^2$

30\*.  $\int_{-1}^3 3 - x dx$  ni toping.

A)  $2$ ; B)  $4,5$ ; C)  $6$ ; D)  $7$ ; E)  $8$ .

31\*.  $\int_0^{2\pi} \sin x dx$  ni toping.

A)  $0$ ; B)  $2$ ; C)  $1$ ; D)  $3$ ; E)  $4$ .

32.  $\int_0^2 (x - \log_2 a) dx = 2 \log_2 \left(\frac{2}{a}\right)$  tenglik  $a$  ning qanday qiymatlari-

da o'rinli bo'ladi?

- A) (1;2); B) (2;  $+\infty$ ); C) (0;  $+\infty$ ); D) (-1;1); E) (4;32).

33\*.  $\int_{-2}^0 (x+1) dx$  ni hisoblang.

- A) 4; B) 3; C) 2; D) -4; E) -3.

34.  $y = x^2 + 4$  funksiya grafigi va  $y = 0$ ,  $x = -1$ ,  $x = 1$  to'g'ri chiziqlar bilan chegaralangan shakl yuzini toping.

- A)  $4\frac{1}{3}$ ; B)  $8\frac{2}{3}$ ; C)  $8\frac{7}{12}$ ; D) 4; E)  $7\frac{2}{3}$ .

35.  $y = \sqrt{x} + 1$  funksiya grafigi,  $Ox$  o'qi,  $x = 1$  to'g'ri chiziq bilan chegaralangan shakl yuzini toping.

- A) 2,5; B) 2; C) 1; D)  $1\frac{2}{3}$ ; E) 3,5.

36.  $y = 1$  to'g'ri chiziq,  $Oy$  o'qi va  $y = \sin x$  funksiyaning  $0 \leq x \leq \frac{\pi}{2}$  kesmadagi grafigi bilan chegaralangan shakl yuzini hisoblang.

- A) 1; B)  $\frac{\pi}{2}$ ; C)  $\frac{\pi}{2} + 1$ ; D)  $\frac{\pi}{2} + 2$ ; E)  $\frac{\pi}{2} - 1$ .

37.  $y = 1$  to'g'ri chiziq,  $y = 2\cos x$  funksiyaning  $-\frac{\pi}{2} \leq x \leq \frac{\pi}{2}$  kesmadagi grafigi bilan chegaralangan shakl yuzini hisoblang.

- A)  $2\left(\sqrt{3} - \frac{\pi}{3}\right)$ ; B)  $\sqrt{3}$ ; C)  $2\sqrt{3}$ ; D)  $4 - \pi$ ; E)  $4 - \frac{\pi}{2}$ .

38.  $y = 4 - x^2$  parabola,  $y = x + 2$  to'g'ri chiziq va  $Ox$  o'qi bilan chegaralangan shakl yuzini toping.

- A) 4,5; B)  $6\frac{1}{6}$ ; C)  $2\frac{2}{3}$ ; D) 4; E)  $5\frac{1}{6}$ .

39.  $y = x^3$ ,  $y = 2x - x^2$  funksiylarning grafiklari va  $Ox$  o'qi bilan chegaralangan shakl yuzini hisoblang.

- A)  $\frac{5}{12}$ ; B) 1; C)  $\frac{7}{12}$ ; D)  $\frac{11}{12}$ ; E) 8.

40.  $y = e^x$ ,  $y = e$  va  $x = 0$  chiziqlar bilan chegaralangan shakl yuzini toping.

A)  $e + 1$ ; B)  $e$ ; C)  $e - 1$ ; D)  $1$ ; E)  $2e$ .

41.  $y = \sin x$ ,  $y = \cos x$ ,  $x = 0$  ( $x \in [0; \frac{\pi}{4}]$ ) chiziqlar bilan chegaralangan shakl yuzini toping.

A)  $3 - \sqrt{2}$ ; B)  $2 - \sqrt{2}$ ; C)  $2 - \sqrt{3}$ ; D)  $\sqrt{3} - 1$ ; E)  $\sqrt{2} - 1$ .

42.  $y = \frac{4}{x}$  giperbola,  $x = 3$ ,  $x = 12$  to'g'ri chiziqlar va  $Ox$  o'qi bilan chegaralangan egri chizikli trapetsiyani absissalar o'qi atrofida aylanishi natijasida hosil bo'lgan jism hajmini toping.

A)  $4\pi$ ; B)  $6\frac{2}{3}\pi$ ; C)  $4,5\pi$ ; D)  $6,5\pi$ ; E)  $5\pi$ .

43.  $y = \sin x$  funksiyaning  $0 \leq x \leq \pi$  kesmadagi grafigi va  $Ox$  o'qi bilan chegaralangan shaklning absissalar o'qi atrofida aylanishidan hosil bo'lgan jism hajmini toping.

A)  $\frac{\pi}{2}(\pi - 1)$ ; B)  $\frac{\pi^2}{4}$ ; C)  $\frac{\pi^2}{2}$ ; D)  $\frac{\pi}{2}(\pi - 4)$ ; E)  $\frac{\pi^3}{2}$ .

44.  $v(t) = (t^2 + t)^m$  tezlik bilan to'g'ri chiziq bo'ylab harakatlanayotgan moddiy nuqta dastlabki 6 s vaqt oralig'ida qancha masofani bosib o'tadi?

A) 80; B) 90; C) 85; D) 96; E) 94 m.

45\*.  $f'(x) = \sin 2x + \frac{1}{x-1}$  tenglamaning umumiy yechimini toping.

A)  $-\frac{1}{2}\cos 2x + \ln|x-1| + C$ ; B)  $\cos 2x + \ln|x-1| + C$ ;

C)  $2\cos 2x + \ln|x-1| + C$ ; D)  $-\cos 2x + \ln|x-1| + C$ ;

E)  $-2\cos 2x + \ln|x-1| + C$ .

46. Quyidagi funksiyalardan qaysi biri  $y' = 2y$  tenglamaning yechimi bo'ladi?

A)  $\frac{c}{2}e^x$ ; B)  $ce^{2x}$ ; C)  $2ce^x$ ; D)  $e^x$ ; E)  $ce^{2x}$ .

47\*.  $xy' + y = 0$  tenglamaning  $y(1) = \frac{1}{2}$  boshlang'ich shartni qanoatlantiruvchi xususiy yechimini toping.

A)  $y = 2x$ ; B)  $y = \frac{1}{2x}$ ; C)  $y = 2e^x$ ; D)  $y = 2e^{2x}$ ; E)  $y = 2\ln x$ .

48\*.  $yy' + x = 0$  tenglamaning  $y(-2) = 4$  boshlang'ich shartni qanoatlantiruvchi xususiy yechimini toping.

A)  $x^2 - y^2 = 10$ ; B)  $x^2 - y^2 = 20$ ; C)  $x^2 + y^2 = 20$ ;

D)  $x^2 + y^2 = 12$ ; E)  $x^2 - y^2 = 12$ ;

49\*. Quyidagi funksiyalardan qaysi biri  $2y'\sqrt{x} = y$  tenglamaning yechimi bo'ladi?

A)  $Ce^{\frac{\sqrt{x}}{2}}$ ; B)  $\frac{C}{2}e^{\sqrt{x}}$ ; C)  $2Ce^x$ ; D)  $Ce^{\sqrt{x}}$ ; E)  $C\sqrt[3]{x^2}$ .

50. To'g'ri chiziq bo'ylab  $v(t) = (6t - t^2)$  m/s tezlik bilan harakatlanayotgan moddiy nuqtaning harakat boshlangandan to'xtaguncha bosib o'tgan yo'lini toping.

A)  $10\frac{1}{3}$  m; B) 36 m; C) 72 m; D) 18 m; E) 20 m.

51.  $2x^2yy' = 1 + x^2$  differensial tenglamaning  $y(1) = 0$  boshlang'ich shartni qanoatlantiruvchi xususiy yechimining aniqlanish sohasini toping.

A)  $(-\infty; +\infty)$ ; B)  $(-\infty; 0)$ ; C)  $(0; +\infty)$ ; D)  $(-\infty; 0) \cup (0; +\infty)$ ;

E)  $(-1; 0) \cup (1; +\infty)$ .

## FOYDALANILGAN ADABIYOTLAR

1. Alimov Sh.A., Xolmuhamedov O.R., Mirzaahmedov M.A. «Algebra». 7-sinf uchun darslik. — T.: «O'qituvchi», 2005.
2. Alimov Sh.A., Xolmuhamedov O.R., Mirzaahmedov M.A. «Algebra». 8-sinf uchun darslik. — T.: «O'qituvchi», 2006.
3. Alimov Sh.A., Xolmuhamedov O.R., Mirzaahmedov M.A. «Algebra». 9-sinf uchun darslik. — T.: «O'qituvchi», 2006.
4. Alimov Sh.A., Xolmuhamedov O.R., Mirzaahmedov M.A. «Algebra va analiz asoslari». 10-sinf uchun darslik. — T.: «O'qituvchi», 2006.
5. Alimov Sh.A., Xolmuhamedov O.R., Mirzaahmedov M.A. «Algebra va analiz asoslari». 11-sinf uchun darslik. — T.: «O'qituvchi», 2006.
6. Амонов А., Сайдаматов Е., Юнусов А., Ходжабагян С. «Основы математического анализа. Экспериментальный учебник для академических лицеев». — Т.: «Политехник», 2004.
7. Вородуля И.Т. «Тригонометрические уравнения и неравенства». — М.: «Просвещение», 1989.
8. Виленкин Х.Я., Ивашев-Мусатов О.С., Шварцбург С.И. «Алгебра и математический анализ для 10-класса, учебное пособие для учащихся школ и классов с углубленным изучением математики». — Т.: «Просвещение», 1992.
9. Виленкин Х.Я., Ивашев-Мусатов О.С., Шварцбург С.И. «Алгебра и математический анализ для 11-класса, учебное пособие для учащихся школ и классов с углубленным изучением математики». — М.: «Просвещение», 1993.
10. Вигодский М.Я. Справочник по элементарной математике. — М.: «Наука», 1972.
11. Галицкий М.Л., Голдман А.М., Звавич Л.И. «Сборник заданий по алгебре для 8-9 классов». — М.: «Просвещение», 1986.

12. Галицкий М.Л., Мошкович М.М., Шварцбург С.И. «Алгебра ва математик анализ курсини чуқур ўрганиш». —Т.: «Ўқитувчи», 1995.

13. Галперин Г.А., Толпиго А.К. «Московские математические олимпиады». —М.: «Просвещение». 1986.

14. Говоров В.М., Дыбов П.Т., Мирошин Х.В., Смирнова С.Ф. «Сборник конкурсных задач по математике». —М.: «Наука», 1986.

15. Давлат тест маркази ахборотномалари. —Т.: 1996-2003.

16. Каганов Е.Д. «400 самых интересных задач о решениями по школьному курсу математики для 6-11 классов». —М.: «ЮН-ВЕС», 1998.

17. Кочетов Е.С., Кочетова Е.С. «Алгебра ва элементар функциялар. I-II қисм. —Т.: «Ўқитувчи», 1967-1970.

18. Крамор В.С. «Повторяем и системазируем школьный курс алгебры и начала анализа». —М.: «Просвещение». 1990.

19. Куланин Е.Д., Хорин В.Р., Федин С.Х., Шевченко Ю.А. «3000 конкурсных задач по математике». —М.: Айрис пресс ролф. 1999.

20. Математикадан масалалар тўплами (Сканави М.Н. таҳрири остида). —Т.: «Ўқитувчи», 1983.

21. Математикадан қўлланма. I-II қисмлар (Азларов Т.А. таҳрири остида). —Т.: «Ўқитувчи», 1979-1990.

22. Мирзааҳмедов М.А., Соғиболдиев Д. «Ўқитувчиларни математик олимпиадаларга тайёрлаш». —Т.: «Ўқитувчи», 1993.

23. Мирзааҳмедов М.А., Раҳимқориев А.А. «Математика, умумий таълим мактабларининг 5-синфи учун дарслик». —Т.: «Ўзбекистон Миллий энциклопедияси» Давлат илмий нашриёти. 2003.

24. Mirzaahmedov M.A., Rahimqoriyev A.A. Matematika, umumiy ta'lim maktablarining 6-sinfi uchun darslik. — Т.: "O'qituvchi", 2005.

25. Нестеренко Ю.В., Олехник С.Х., Погапов М.К. «Задачи вступительных экзаменов по математике». —М.: «Наука». 1980.

27. «Пособие по математике для поступающих в ВУЗы». (Под редакцией Г.Х.Яковлева). —М.: «Наука», 1985.

28. Раҳимқориев А.А. Мирзааҳмедов М.А. «Математикадан масалалар тўплами, 5-синф учун». —Т.: «Ўқитувчи», 1998.

29. Саакян С.М., Голдман А.М., Денисов Д.В. «Задачи по алгебре и началам анализа для 10-11 классов». —М.: «Просвещение», 1990.

30. Сахаев М.С. «Элементар математика масалалари тўплами. I-II қисм». —Т.: «Ўқитувчи», 1970-1972.

31. Усмонов Ф.Р., Исомов Р.Д., Исомова М. «Алгебраик трансцендент ва параметрли тенгламалар бўйича тестларни ечиш учун услубий қўлланма». —Т.: «Шарқ», 2001.



## Test topshirihlarining javoblari

### I bob

1	2	3	4	5	6	7	8	9	10	11	12	13	14	15	16	17	18	19	20
C	D	B	E	C	C	D	A	E	C	A	C	A	D	B	B	D	E	D	C

21	22	23	24	25
B	C	A	C	A

### II bob

1	2	3	4	5	6	7	8	9	10	11	12	13	14	15	16	17	18	19	20
D	B	C	D	E	B	A	C	E	D	E	B	D	B	C	C	E	C	C	D

21	22	23	24	25	26	27	28	29	30	31	32	33	34	35	36	37	38	39	40
B	D	E	E	A	A	D	B	C	E	B	D	A	A	C	E	C	E	E	E

41	42	43	44	45	46	47	48	49	50	51	52	53	54	55	56	57	58	59	60
C	B	C	D	D	B	C	D	B	A	C	A	C	B	E	C	B	D	C	E

### III bob

1	2	3	4	5	6	7	8	9	10	11	12	13	14	15	16	17	18	19	20
C	B	C	E	A	B	C	E	D	B	B	C	C	B	B	D	B	C	C	B

21	22	23	24	25	26	27	28	29	30	31	32	33	34	35	36	37	38	39	40
C	E	B	E	A	B	D	D	B	D	C	D	E	D	C	C	D	A	D	B

41	42	43	44	45	46	47	48	49	50
E	B	D	A	B	C	A	E	B	C

### IV bob

1	2	3	4	5	6	7	8	9	10	11	12	13	14	15	16	17	18	19	20
C	D	E	B	B	C	E	D	D	B	B	A	C	C	C	A	D	B	C	E

21	22	23	24	25	26	27	28	29	30	31	32	33	34	35	36	37	38	39	40
A	E	B	E	E	E	B	C	C	D	B	E	D	B	B	C	A	E	A	B

41	42	43	44	45	46	47	48	49	50
A	D	E	B	B	C	A	D	C	B

V bob

1	2	3	4	5	6	7	8	9	10	11	12	13	14	15	16	17	18	19	20
C	A	D	C	D	A	E	D	A	B	B	A	A	C	E	C	A	D	B	E

21	22	23	24	25	26	27	28	29	30	31	32	33	34	35	36	37	38	39	40
B	D	C	A	E	C	B	D	B	A	D	A	C	C	C	E	D	B	A	E

41	42	43	44	45
A	D	D	E	A

VI bob

1	2	3	4	5	6	7	8	9	10	11	12	13	14	15	16	17	18	19	20
C	D	A	C	A	B	E	C	C	D	B	A	D	E	C	E	A	B	C	E

21	22	23	24	25	26	27	28	29	30	31	32	33	34	35	36	37	38	39	40
D	C	B	A	E	C	A	A	C	D	B	D	C	A	E	D	D	A	A	D

41	42	43	44	45	46	47	48	49	50	51	52	53	54	55	56	57	58	59	60
E	B	C	C	A	A	C	A	D	B	C	E	A	A	D	B	B	C	E	A

61	62	63	64	65
D	A	C	D	D

VII bob

1	2	3	4	5	6	7	8	9	10	11	12	13	14	15	16	17	18	19	20
A	B	E	C	D	E	B	C	C	D	A	D	E	A	E	A	C	C	A	A

21	22	23	24	25	26	27	28	29	30	31	32	33	34	35	36	37	38	39	40
B	D	A	A	C	D	B	C	D	A	D	A	A	D	B	E	B	B	B	A

41	42	43	44	45	46	47	48	49	50	51	52	53	54	55	56	57	58	59	60
C	E	B	D	B	A	C	D	B	E	B	C	A	D	A	E	B	E	E	B

61	62	63	64	65
A	C	B	A	B

VIII bob

1	2	3	4	5	6	7	8	9	10	11	12	13	14	15	16	17	18	19	20
D	A	D	B	C	C	B	D	B	E	C	A	B	B	A	D	D	E	C	A

21	22	23	24	25	26	27	28	29	30	31	32	33	34	35	36	37	38	39	40
B	A	E	D	A	B	D	A	A	C	C	C	C	A	E	D	A	A	B	A

41	42	43	44	45	46	47	48	49	50	51	52	53	54	55	56	57	58	59	60
B	E	A	B	C	E	E	D	D	D	C	A	E	B	A	B	C	C	A	E

61	62	63	64	65
B	E	A	C	A

IX bob

1	2	3	4	5	6	7	8	9	10	11	12	13	14	15
A	A	A	A	A	A	A	A	A	B	B	B	D	E	B

X bob

1	2	3	4	5	6	7	8	9	10	11	12	13	14	15	16	17	18	19	20
A	A	B	D	A	C	A	E	B	D	A	E	A	C	C	A	D	B	D	E

21	22	23	24	25	26	27	28	29	30	31	32	33	34	35
E	A	A	E	C	D	C	C	D	A	D	E	D	B	C

XI bob

1	2	3	4	5	6	7	8	9	10	11	12	13	14	15	16	17	18	19	20
B	B	D	A	D	A	E	B	C	E	A	C	B	A	E	C	A	B	C	A

21	22	23	24	25	26	27	28	29	30	31	32	33	34	35	36	37	38	39	40
B	D	E	C	D	A	E	B	E	A	C	D	D	A	B	E	C	D	E	A

41	42	43	44	45	46	47	48	49	50	51	52	53	54	55	56	57	58	59	60
D	A	B	A	E	A	D	E	C	E	B	C	D	E	B	B	C	A	D	E
61	62	63	64	65	66	67	68	69	70	71	72	73	74	75					
C	C	B	A	E	A	D	B	C	E	A	B	D	A	A					

XII bob

1	2	3	4	5	6	7	8	9	10	11	12	13	14	15	16	17	18	19	20
C	D	A	E	E	D	A	D	A	B	E	A	A	B	A	C	D	B	C	C
21	22	23	24	25	26	27	28	29	30	31	32	33	34	35	36	37	38	39	40
E	D	A	C	D	A	B	D	C	A	D	B	D	E	E	C	A	D	A	A
41	42	43	44	45	46	47	48	49	50	51	52	53	54	55	56	57	58	59	60
D	A	E	C	A	A	B	B	C	E	B	B	C	A	E	D	B	E	B	C
61	62	63	64	65	66	67	68	69											
A	C	E	A	B	B	A	A	A											

XIII bob

1	2	3	4	5	6	7	8	9	10	11	12	13	14	15	16	17	18	19	20
A	B	C	D	E	A	E	C	A	C	B	D	B	C	E	A	C	C	D	A
21	22	23	24	25	26	27	28	29	30	31	32	33	34	35	36	37	38	39	40
A	C	D	B	D	A	B	D	A	E	A	B	A	A	C	E	A	B	E	D
41	42	43	44	45	46	47	48	49	50	51	52	53	54	55	56	57	58	59	60
C	C	B	A	A	D	B	C	A	A	B	D	A	C	D	A	B	A	A	E
61	62	63	64	65															
E	A	E	C	A															

XIV bob

1	2	3	4	5	6	7	8	9	10	11	12	13	14	15	16	17	18	19	20
E	B	C	B	B	A	D	A	B	D	D	C	C	A	A	E	A	B	C	E

21	22	23	24	25	26	27	28	29	30	31	32	33	34	35	36	37	38	39	40
B	D	A	E	D	A	B	B	E	B	A	C	D	C	B	A	C	E	A	D

41	42	43	44	45	46	47	48	49	50	51	52	53	54	55	56	57	58	59	60
B	A	A	B	D	E	A	B	C	E	D	B	A	A	A	C	E	B	C	C

61	62	63	64	65	66	67	68	69	70	71	72	73	74	75	76	77	78	79	80
A	D	D	A	A	D	E	C	C	C	A	A	C	D	C	B	E	A	D	A

81	82	83	84
D	A	D	A

XV bob

1	2	3	4	5	6	7	8	9	10	11	12	13	14	15	16	17	18	19	20
B	C	A	D	B	A	A	D	C	A	E	B	C	A	C	E	B	C	A	D

21	22	23	24	25	26	27	28	29	30	31	32	33	34	35	36	37	38	39	40
A	E	A	A	C	B	E	D	C	E	E	C	A	B	D	E	A	B	D	D

41	42	43	44	45	46	47	48	49	50	51
E	A	C	B	A	E	B	C	D	B	E

## MUNDARIJA

Soʻz boshi .....	3
------------------	---

### I BOB. Natural sonlar

<i>1-§. Natural sonlar va ular ustida amallar</i> .....	5
1.1. Raqam, natural son tushunchalari (5). 1.2. Natural sonlar ustida amallar (5).	
<i>2-§. Sonlarning boʻlinish belgilari</i> .....	8
<i>3-§. Tub va murakkab sonlar</i> .....	9
3.1. Natural sonlarning turlari (9). 3.2. Berilgan natural sonlarning eng katta umumiy boʻluvchisi (9). 3.3. Berilgan natural sonlarning eng kichik umumiy karralisi (10). 3.4. Murakkab sonning boʻluvchilari soni (11). 3.5. Natural sonlarning umumiy boʻluvchilari soni (11)	
Mustaqil ishlash uchun test topshiriqlari .....	12

### II BOB . Ratsional sonlar va irratsional sonlar

<i>1-§. Oddiy kasrlar</i> .....	15
<i>2-§. Oddiy kasrlar ustida arifmetik amallar</i> .....	16
<i>3-§. Oʻnli kasrlar va ular ustida amallar</i> .....	19
<i>4-§. Davriy oʻnli kasrlar</i> .....	21
<i>5-§. Oddiy va oʻnli kasrlar qatnashgan sonli ifodalarning qiymatlarini hisoblash</i> .....	22
<i>6-§. Nisbat va proporsiya. Protsent</i> .....	24
<i>7- §. Oʻrta qiymatlar</i> .....	28
7.1. Oʻrta arifmetik qiymat (28). 7.2. Oʻrta geometrik qiymat (29). 7.3. Oʻrta vaznli qiymat (30). 7.4. Oʻrta garmonik qiymat (31).	
<i>8-§. Haqiqiy sonlar toʻplami</i> .....	32
8.1. Ratsional va irratsional sonlar (32). 8.2. Son oʻqi (33). 8.3. Sonning moduli (absolut qiymati) (34).	
Mustaqil ishlash uchun test topshiriqlari .....	35

### III BOB. Birhadlar va koʻphadlar

<i>1-§. Natural va butun koʻrsatkichli daraja</i> .....	42
1.1. Natural koʻrsatkichli daraja (42). 1.2. Natural koʻrsatkichli darajaning xossalari (42). 1.3. Nol koʻrsatkichli daraja. Butun manfiy koʻrsatkichli daraja (42).	
<i>2-§. Birhadlar va koʻphadlar</i> .....	44

2.1. Birhadlar (44). 2.2. Ko'phadlar (45). 2.3. Ko'phadlar va birhadlar ustida amallar (45).	
<b>3-§. Qisqa ko'paytirish formulalari</b> .....	46
<b>4-§. Ko'phadni ko'paytuvchilarga ajratish</b> .....	47
4.1. Umumiy ko'paytuvchini qavsdan tashqariga chiqarish usuli (47). 4.2. Guruhlash usuli (47). 4.3. Qisqa ko'paytirish formulalaridan foydalanib ko'paytuvchilarga ajratish usuli (48).	
<b>5-§. Algebraik kasr</b> .....	49
5.1. Algebraik kasrlarni qisqartirish (49). 5.2. Algebraik kasrlarni qo'shish (50). 5.3. Algebraik kasrlarni ko'paytirish va bo'lish (50). 5.4. Algebraik kasrlar ustida birgalikda bajariladigan amallar (51)	
Mustaqil ilshash uchun test topshiriqlari .....	52

#### **IV BOB. Chiziqli tenglamalar va tengsizliklar**

<b>1-§. Bir noma'lumli tenglamalar</b> .....	59
<b>2-§. Birinchi darajali bir noma'lumli tenglamalar</b> .....	60
<b>3-§. Tekislikda to'g'ri burchakli koordinatalar sistemasi</b> .....	61
<b>4-§. Chiziqli funksiya va uning grafigi</b> .....	63
4.1. Funksiya tushunchasi (63). 4.2. Chiziqli funksiya (64).	
<b>5-§. Birinchi darajali ikki noma'lumli tenglamalar sistemasi</b> .....	65
5.1. Tenglamalar sistemasining yechimi (65). 5.2. Tenglamalar sistemasini yechish (65). 5.3. Agar tenglamalar sistemasi (65). 5.8. Ikki noma'lumli chiziqli tenglamalar sistemasini o'rniga qo'yish usuli bilan yechish (67). 5.9. Chiziqli tenglamalar sistemasini algebraik qo'shish (noma'lumlardan birini yo'qotish) usuli bilan yechish (68). 5.10. Chiziqli tenglamalar sistemasini grafik usul bilan yechish (69).	
<b>6-§. Ikkinchi tartibli determinantlar</b> .....	71
6.1. Ikkinchi tartibli determinant tushunchasi (71). 6.2. Ikkinchi tartibli determinantni chiziqli tenglamalar sistemasini yechishdagi tatbiqi (71).	
<b>7-§. Parametrlı chiziqli tenglamalar, tenglamalar sistemasi</b> .....	73
<b>8-§. Sonli tengsizliklar</b> .....	76
8.1. Tengsizlik tushunchasi (76). 8.7. Tengsizliklarning asosiy xossalari (77). 8.8. Tarkibida noma'lum qatnashgan tengsizliklar (78)	
<b>9-§. Chiziqli tengsizliklar</b> .....	79
9.1. Chiziqli tengsizlik tushunchasi (79). 9.2. Sonli oraliqlar (79). 9.3. Bir o'zgaruvchili tengsizliklarni yechish (80).	

<b>10-§. Chiziqli tengsizliklar sistemasi</b> .....	81
10.1. Chiziqli tengsizliklar sistemasini yechish (82).	
<b>11-§. Chiziqli tengsizliklarni yechishning grafik usuli</b> .....	84
11.1. $kx > n$ tengsizlikni yechishning grafik usuli (84). 11.2. Bir o'zgaruvchili chiziqli tengsizliklar sistemasini grafik usul bilan yechish (84).	
<b>12-§. Noma'lumlari modul belgisi ostida bo'lgan tenglamalar va tengsizliklar</b> .....	85
12.1. Modulli tenglamalar (85). 12.2. Oraliqlar usuli (86). 12.3. Modulli tengsizliklar (86).	
Mustaqil ishlash uchun test topshiriqlari .....	90

### V BOB. Ratsional ko'rsatkichli daraja

<b>1-§. Kvadrat ildizlar</b> .....	96
1.1. Arifmetik kvadrat ildiz (96). 1.2 Arifmetik kvadrat ildizning xossalari (96)	
<b>2-§. <math>y = x^2</math> va <math>y = \sqrt{x}</math> funksiyalar. Ularning grafiklari</b> .....	97
2.1. $y = x^2$ funksiya (97). 2.2. $y = \sqrt{x}$ funksiya (98)	
<b>3-§. Kvadrat ildizlar qatnashgan ifodalarni shakl almashtirish</b> .....	98
<b>4-§. Ratsional ko'rsatkichli daraja</b> .....	103
4.1. Haqiqiy $a$ sonning $n$ - darajali ildizi (103). 4.2. $n$ - darajali arifmetik ildiz (104). 4.3. $n$ - darajali arifmetik ildizning xossalari (104). 4.4. Ratsional ko'rsatkichli daraja (107). 4.5. Ratsional ko'rsatkichli kasr ifodalar maxrajidagi irratsionallikdan qutilish (113).	
Mustaqil ishlash uchun test topshiriqlari .....	115

### VI BOB. Kvadrat tenglamalar

<b>1-§. Kvadrat tenglama tushunchasi</b> .....	120
1.1. Kvadrat tenglama (120). 1.2. Chala (to'liqmas) kvadrat tenglama (120). 1.3. To'la kvadrat tenglamani yechish (121). 1.4. Keltirilgan kvadrat tenglama (122)	
<b>2-§. Viyet teoremasi</b> .....	123
<b>3-§. Kvadrat tenglamaga keltiriladigan yuqori darajali tenglamalar</b> .	127
3.1. Bikvadrat tenglamalar (127). 3.2. Qaytma tenglamalar (128). 3.3. O'zaro teskari ifodalar ishtirok etgan tenglamalar (129). 3.4. To'la kvadratni ajratish usuli bilan kvadrat tenglamaga keltiriladigan to'rtinchi darajali tenglamalar (130).	



4-§. Yuqori darajali tenglamalar sistemalari .....	131
5-§. Kvadrat uchhad .....	137
5.1. Kvadrat uchhad tushunchasi (137). 5.2. Kvadrat uchhadni chiziqli ko'paytuvchilarga ajratish (137).	
6-§. Ratsional tenglamalar .....	139
7-§. Kvadrat funksiya va uning grafigi .....	142
7.1. Kvadrat funksiya tushunchasi (142).	
7.2. $y = ax^2$ funksiya grafigi (142). 7.3. $y = a(x + x_0)^2$ funksiyaning grafigi (142). 7.4. $y = a(x + x_0)^2 + y_0$ funksiyaning grafigi (144). 7.5. $y = ax^2 + bx + c$ funksiyaning grafigi (144).	
Mustaqil ishlash uchun test topshiriqlari .....	146

## VII BOB. Ikkinchi darajali tengsizliklar. Irratsional tenglamalar va tengsizliklar

1-§. Ikkinchi darajali tengsizliklar .....	154
2-§. Tengsizliklarni yechishning oraliqlar usuli .....	157
3-§. Irratsional tenglamalar .....	162
3.1. Irratsional tenglamalarning chet ildizlari (162).	
3.2. Irratsional tenglamalarni yechishga doir misollar (163).	
4-§. Irratsional tengsizliklar .....	165
4.1. Irratsional tengsizlik tushunchasi (165). 4.2. Irratsional tengsizliklarni yechilishiga doir misollar (167).	
Mustaqil ishlash uchun test topshiriqlari .....	170

## VIII BOB. Haqiqiy sonlar to'plamida aniqlangan funksiya

1-§. Funksiya tushunchasi .....	178
1.1. O'zgarmas va o'zgaruvchi miqdorlar (178). 1.2. Funksiyaning umumiy ta'rifi (179). 1.3. Funksiyaning aniqlanish sohasi va qiymatlar to'plami (180).	
2-§. Funksiyaning berilish usullari .....	182
2.1. Funksiyaning analitik usulda berilishi (182).	
2.2. Funksiyaning jadval usulda berilishi (183). 2.3. Funksiyaning grafik usulda berilishi (184).	
3-§. Funksiyalarning umumiy xossalari .....	185
3.1. Juft va toq funksiyalar (185). 3.2. Funksiyalarning o'sishi va kamayishi. Funksiyaning monotonligi (186).	
3.3. Funksiyaning nollari (187). 3.4. Davriy funksiyalar. (187).	
4-§. $y = [x]$ va $y = \{x\}$ funksiyalar .....	190
5-§. Funksiyalar graflarini geometrik almashtirish .....	191
6-§. $y = x^n$ funksiyaning xossalari va grafigi .....	194

6.1. $y = x^3$ funksiya (194).	6.2. $y = x^{2n}$ funksiya (194).
6.3. $y = x^{2n+1}$ funksiya (195).	
7-§. $y = \frac{k}{x}$ funksiya va uning grafigi .....	195
7.3. $y = \frac{k}{x}$ funksiya xossalari va grafigi (195).	
8-§. Kasr-chiziqli funksiya va uning grafigi .....	196
9-§. $y =  x $ va $y =  ax + b  +  cx + d $ funksiyalar grafiglari .....	198
9.1. $y =  x $ funksiya (198).	9.2. $y =  ax + b  +  cx + d $ funksiya grafigi (199).
10- §. Teskari funksiya. Teskari funksiyaning grafigi .....	200
10.1. Teskari funksiya tushunchasi (200).	10.2. Teskari funksiyaning grafigi (202).
Mustaqil ishlash uchun test topshiriqlari .....	203

### IX BOB. Bir o'zgaruvchili ko'phadlar va ular ustida amallar

1-§. Ko'phad tushunchasi .....	212
2-§. Ko'phadlar ustida amallar .....	213
2.1. Ko'phadlarni qo'shish, ayirish va ko'paytirish (213).	2.2. Ko'phadni ko'phadga bo'lish (211).
2.3. Ko'phadni ko'phadga qoldiqli bo'lish (216).	
3-§. Ko'phadni ikkihadga bo'lish. Gornersxemasi. Bezu teoremasi .	216
3.1. Gornersxemasi (216).	3.2. Bezu teoremasi (218).
4- §. Ko'phadning ildizlari .....	219
Mustaqil ishlash uchun test topshiriqlari .....	222

### X BOB. Sonli ketma-ketliklar. Progressiyalar

1-§. Chekli va cheksiz sonli ketma-ketliklar .....	224
1.1. Sonli ketma-ketlikning berilish usullari (224).	1.2. Monoton ketma-ketliklar (225).
1.3. Ketma-ketlikning geometrik tasviri (226).	1.4. Yaqinlashuvchi va uzoqlashuvchi ketma-ketliklar. Ketma-ketlikning limiti (228).
1.5. Limitlar haqida teoremlar (229).	
2-§. Cheksiz kichik ketma-ketliklar .....	230
2.1. Cheksiz kichik tushunchasi (230).	2.2. Cheksiz kichiklarning ba'zi xossalari (230).
3-§. Arifmetik progressiya .....	232
4-§. Geometrik progressiya .....	234
Geometrik progressiyaning xossalari .....	235
5-§. Cheksiz kamayuvchi geometrik progressiya .....	237
Mustaqil ishlash uchun test topshiriqlari .....	238

## XI BOB. Ko'rsatkichli va logarifmik funksiyalar

<b>1-§. Ko'rsatkichli funksiya, uning xossalari va grafigi</b> .....	243
<b>2-§. Ko'rsatkichli tenglamalar</b> .....	244
2.1. Ko'rsatkichli tenglamalarni yechish usullari (244).	
2.2. Ko'rsatkichli tenglamalar sistemalari (248)	
<b>3-§. Ko'rsatkichli tengsizliklar</b> .....	249
3.1. Ko'rsatkichli tengsizliklarni yechish usullari (249).	
3.2. Ko'rsatkichli tengsizliklarni yechishga doir misollar (250).	
<b>4-§. Logarifmlar</b> .....	252
4.1. Sonning logarifmi (252). 4.2. Logarifmning xossalari (254).	
4.3. Ko'paytmaning, bo'linmaning va darajaning logarifmi (255).	
4.4. O'nli va natural logarifmlar (255). 4.5. Logarifmning yangi asosiga o'tish formulasi (256)	
<b>5-§. Logarifmik funksiya, uning grafigi va xossalari.</b> .....	257
<b>6-§. Logarifmik tenglamalar</b> .....	260
6.1. Logarifmik tenglamalarni yechish usullar (260).	
6.2. $\log_a f(x) = \log_a \varphi(x)$ tenglamani $f(x) = \varphi(x)$ tenglamaga teng kuchli ekanligidan foydalanib yechiladigan tenglamalar (261).	
6.3. Yordamchi o'zgaruvchi kiritish usuli bilan yechiladigan tenglamalar (262).	
6.4. Bir xil asosga o'tish usuli (263).	
6.5. Logarifmlash usuli (263).	
6.6. Logarifmik tenglamalar sistemasi (263).	
<b>7-§. Logarifmik tengsizliklar</b> .....	264
7.1. Logarifmik tengsizliklarni yechish (264).	
7.2. Logarifmik tengsizliklarni yechishga doir misollar (264).	
7.3. Logarifmik tengsizliklar sistemasi (267).	
Mustaqil ishlash uchun test topshiriqlari .....	268

## XII BOB. Trigonometriya elementlari. Trigonometrik funksiyalar

<b>1-§. Burchaklarning gradus va radian o'lchovlari</b> .....	276
1.1. Burchakning gradus o'lchovi (276). 1.2. Burchaklarning ishoralari (276). 1.3. Burchakning radian o'lchovi (277).	
<b>2-§. Son argumentining sinusi, kosinusi, tangensi, kotangensi, sekansi, kosekansi</b> .....	278
<b>3-§. Sinus, kosinus, tangens va kotangensning ishoralari</b> .....	282
<b>4-§. Asosiy trigonometrik ayniyatlar</b> .....	284
4.1. Asosiy ayniyat (284). 4.2. Ayni bir burchakning sinusi, kosinusi, tangensi va kotangensi orasidagi munosabatlar (285).	
<b>5-§. Keltirish formulalari</b> .....	288

<b>6-§. Asosiy trigonometrik formulalar</b> .....	290
6.1. Qo'shish formulalari (290). 6.2. Ikkilangan va yarimburchak formulalari (291). 6.3. Bir ismli trigonometrik funksiyalar yig'indisi va ayirmasi uchun formulalar (294). 6.4. Ko'paytmani yig'indiga keltirish formulalari (296). 6.5. Ba'zi muhim munosabatlar (298).	
<b>7-§. Trigonometrik funksiyalar</b> .....	298
7.1. Trigonometrik funksiyalarning juft-toqligi (299). 7.2. Trigonometrik funksiyalarning davriyligi (300). 7.3. $y = \sin x$ funksiyaning xossalari va grafigi (302). 7.4. $y = \cos x$ funksiyaning xossalari va grafigi (303). 7.5. $y = \operatorname{tg} x$ funksiyaning xossalari va grafigi (305). 7.6. $y = \operatorname{ctg} x$ funksiyaning xossalari va grafigi (306).	
<b>8-§. Teskari trigonometrik funksiyalar. Arksinus, arkkosinus, arktangens va arkkotangens</b> .....	308
8.1. Teskari trigonometrik funksiya tushunchasi. $y = \arcsin x$ funksiya (308). 8.2. $y = \arcsin x$ funksiyaning asosiy xossalari (310). 8.3. $y = \arccos x$ funksiya (310). 8.4. $y = \arccos x$ funksiyaning asosiy xossalari (310). 8.5. $y = \operatorname{arctg} x$ funksiya (311). 8.6. $y = \operatorname{arctg} x$ funksiyaning asosiy xossalari (311). 8.7. $y = \operatorname{arctg} x$ funksiya (312). 8.8. $y = \operatorname{arctg} x$ funksiyaning asosiy xossalari (312). 8.9. Teskari trigonometrik funksiyalar uchun ayniyatlar (313).	
Mustaqil ishlash uchun test topshiriqlari .....	315

### XIII BOB. Trigonometrik tenglamalar va tengsizliklar

<b>1-§. Trigonometrik tenglamalar</b> .....	324
1.1. $\sin x = a$ ( $ a  \leq 1$ ) tenglama (324). 1.2. $\cos x = a$ ( $ a  \leq 1$ ) tenglama (235). 1.3. $\operatorname{tg} x = a$ va $\operatorname{ctg} x = a$ tenglamalar (326).	
<b>2-§. Trigonometrik tenglamalarning ayrim turlari va ularni yechish usullari</b> .....	328
2.1 Algebraik tenglamalarga keltiriladigan tenglamalar (328). 2.2. Bir jinsli tenglamalar (329). 2.3. Ko'paytuvchilarga ajratib yechiladigan tenglamalar (330). 2.4. Bir ismli trigonometrik funksiyalarning tenglik shartlaridan foydalanib yechiladigan tenglamalar (332). 2.5. $a \sin x + b \cos x = c$ shaklidagi tenglamalar (333).	
<b>3-§. Teskari trigonometrik funksiyalar qatnashgan tenglamalar</b> .....	335
<b>4-§. Trigonometrik tengsizliklar</b> .....	337

4.1. $\sin x > a$ , $\sin x < a$ tengsizliklarni yechish (337).	
4.2. $\cos x > a$ , $\cos x < a$ tengsizliklarni yechish (342).	
4.3. $\operatorname{tg} x > a$ , $\operatorname{tg} x < a$ tengsizliklarni yechish (346).	
Mustaqil ishlash uchun test topshiriqlari .....	350

#### **XIV BOB. Hosila va uning tatbiqlari**

<b>1-§. Funksiyaning limiti</b> .....	<b>360</b>
1.1. Funksiyaning nuqtadagi limiti (360).	
1.2. Bir tomonlama limitlar (361).	
1.3. Funksiyaning cheksizlikdagi limiti (362).	
1.4. Funksiyalarning limitlari haqidagi asosiy teoremlar (363).	
<b>2-§. Birinchi va ikkinchi ajoyib limitlar</b> .....	<b>365</b>
2.1. Birinchi ajoyib limit (365).	
2.2. Ikkinchi ajoyib limit. $e$ soni (367).	
<b>3-§. Funksiyaning uzluksizligi</b> .....	<b>369</b>
3.1. Funksiyaning nuqtada va oraliqda uzluksizligi (369).	
3.2. Nuqtada uzluksiz funksiyalarning xossalari (369).	
<b>4-§. Erkli o'zgaruvchi va funksiya orttirmasi</b> .....	<b>371</b>
<b>5-§. Hosila</b> .....	<b>372</b>
5.1. Hosilaning ta'rifi (372).	
5.2. Differensiallashning asosiy qoidalari (374).	
5.3. Darajali funksiyaning hosilasi (376).	
5.4. Murakkab funksiyaning hosilasi (376).	
<b>6-§. Hosilaning geometrik va fizik ma'nolari</b> .....	<b>377</b>
6.1. Hosilaning geometrik ma'nosi (377).	
6.2. Urinma tenglamasi (379).	
6.3. Hosilaning mexanik ma'nosi (380).	
<b>7-§. Ba'zi elementar funksiyalarning hosilalari</b> .....	<b>382</b>
7.1. Trigonometrik funksiyalarning hosilalari (382).	
7.2. Teskari trigonometrik funksiyalarning hosilalari (383).	
7.3. Logarifmik va ko'rsatkichli funksiyalarning hosilalari (383).	
7.4. Asosiy elementar funksiyalarni differensiallash formulalari (384).	
<b>8-§. Hosilaning taqribiy hisoblashlarga tatbiqi</b> .....	<b>388</b>
8.1. Funksiya orttirmasining bosh qismi (388).	
8.2. Taqribiy hisoblashlarda differensialdan foydalanish (389).	
<b>9-§. Hosilani funksiyalarining o'sish va kamayish oraliqlarini topishga tatbiqi</b> .....	<b>390</b>
<b>10-§. Funksiyaning ekstremumlari</b> .....	<b>392</b>
10.1. Funksiyaning maksimumi va minimumi (392).	
10.2. Ekstremum mavjudligining zaruriy sharti (393).	
10.3. Ekstremumning yetarlilik shartlari (394).	
<b>11-§. Funksiyani hosila yordamida tekshirish va uning grafigini yasash</b> .....	<b>397</b>

12-§. <i>Funksiyaning eng katta va eng kichik qiymatlari</i> .....	399
13-§. <i>Ikkinchi tartibli hosila tushunchasi.</i>	
Yuqori tartibli hosilalar .....	401
14-§. <i>Ko'phadning koeffitsiyentlarini shu ko'phad hosilalarning qiymatlari orqali ifodalash</i> .....	402
15-§. <i>Nyuton binomi</i> .....	403
Mustaqil ishlash uchun test topshiriqlari .....	404

## XV BOB. Boshlang'ich funksiya va integral

1-§. <i>Boshlang'ich funksiya. Aniqmas integral</i> .....	416
1.1. Boshlang'ich funksiya tushunchasi (416). 1.2. Aniqmas integral (417). 1.3. Boshlang'ich funksiyalar jadvali (418).	
2-§. <i>Aniqmas integralda o'zgaruvchini almashtirish</i> .....	421
3-§. <i>Bo'laklab integrallash</i> .....	423
4-§. <i>Egri chizikli trapetsiyaning yuzi. Aniq integral</i> .....	424
4.1. Egri chizikli trapetsiyaning yuzini hisoblash (424). 4.2. Aniq integral (245). 4.3. Aniq integralning xossalari (426).	
5-§. <i>Aniq integrallarni yuzlarni hisoblashga tatbiqi</i> .....	429
6-§. <i>Aylanish jismlarining hajmini hisoblash</i> .....	431
7-§. <i>Eng sodda differensial tenglamalar</i> .....	432
7.1. Differensial tenglamaga keltiriladigan ayrim masalalar (432).	
7.2. Oddiy differensial tenglamalarga oid asosiy tushunchalar (435). 7.3. O'zgaruvchilari ajraladigan differensial tenglamalar (436).	
Mustaqil ishlash uchun test topshiriqlari .....	438
Foydalanilgan adabiyotlar .....	447
Test topshirihlarining javoblari .....	450

*O'quv-uslubiy nashr*

F. USMONOV, R. ISOMOV, B.XO'JAYEV

**MATEMATIKADAN  
QO'LLANMA**

*(O'quv qo'llanma)*

Muharrir *O'.Husanov*

Tex. muharrir *Ye.Demchenko*

Musahhib *N.Jabborova*

Kompyuterda sahifalovchi *K.Nazarova*

IB № 41141

Bosishga 16.08.2006-y.da ruxsat etildi.

Bichimi 84x108 1/32. Bosma tobog'i 1,875. Shartli bosma tobog'i 18,80.

Adadi 2000 nusxa, Buyurtma № 174.

«Yangi asr avlodi» nashriyot-matbaa markazida tayyorlandi.

«Yoshlar matbuoti» bosmaxonasida bosildi.

700113. Toshkent. Chilonzor-8. Qatortol ko'chasi, 60.





